



*Microprocessor Controlled
IGBT Drive
Inverter Motor Speed Regulator
Operating Manual*

High Performance Adjustable Speed Micro Drives

E2 Series	110V	0.2~0.75KW (0.53~1.6KVA)
	220V	0.2~2.2KW (0.53~4.0KVA)
	440V	0.75~2.2KW (1.7~4.0KVA)

Operations Manual

Table of Contents

Foreword	1
Chapter 1 Safety Precautions	
1. Precautions for Operation	3
2. Environmental Precautions	6
Chapter 2 Hardware Instruction and Installation	
1. Operational Environment.....	7
2. Sample Model No. Identification.....	8
3. Specifications	9
4. Wiring	15
5. Dimensions & Location of terminal block	18
Chapter 3 Software Index	
1. Keypad Operating Instructions	30
2. Parameters List	31
3. Parameter Function Description.....	32
4. Malfunction Indication and Countermeasure	44
5. General Malfunction Examination Method	47
Chapter 4 Trouble Shooting Procedure	
1. Flow Chart.....	48
2. Maintenance Examination	56

1. Foreword

To fully employ all functions of this AC Drive, and to ensure the safety for its users, please read through this operations manual in detail. Should you have any further questions, please feel free to contact your local distributor or regional representative.

Please use Precaution with this product

The AC Drive is a power electronic device. For safety reasons, please read carefully those paragraphs with “WARNING” or “CAUTION” symbols. They are important safety precautions to be aware of while transporting, installation, operating or examining the AC drive. Please follow these precautions to ensure your safety.

 **WARNING**

Personnel injury may be resulted by improper operation.

 **CAUTION**

The AC Drive or mechanical system may be damaged by improper operation.

 **WARNING**

- Do not touch the PCB or components on the PCB right after turning off the power before the charging indicator went off.
- Do not attempt to wire circuitry while power is on. Do not attempt to examine the components and signals on the PCB while the inverter operating.
- Do not attempt to disassemble or modify internal circuitry, wiring, or components of the inverter.
- The grounding terminal of the inverter must be grounded properly with 200V class type III standard.
- This is a product of the restricted sales distribution class according to EN61800-3.
In a domestic environment this product may cause radio interference in which case the user may be required to take adequate measures.

 **CAUTION**

- Do not attempt to perform dielectric strength test to internal components of the inverter. There are sensitive semiconductor-devices vulnerable to high voltage in the inverter.
- Do not connect the output terminals: T1 (U), T2 (V), and T3 (W) to AC power input
- The CMOS IC on the primary PCB of the inverter is vulnerable to static electrical charges. Do not contact the primary PCB of the inverter.

2. Examination before installation

Every inverter has been fully tested and examined before shipment. Please carry out the following examination procedures after unpacking your AC inverter.

- Check to see if the model number of the AC inverter matches the model number of the AC inverter that you ordered.
- Check to see whether any damage occurred to the AC inverter during shipment. Do not connect the AC inverter to the power supply if there is any sign of damage.

Report this to a regional sale representative if you find any abnormal condition as mentioned above.

Chapter 1: Safety Precaution

1. Precautions for operation

Before turning ON power

CAUTION

Choose the appropriate power source with correct voltage settings for the input voltage specification of the AC inverter.

WARNING

Special care must be taken while wiring the primary circuitry panel. The L1 and L2 terminal must be connected to the input power source and must not be mistakenly connected to T1, T2 or T3 out put terminals. This may damage the inverter when the power is turned on.

CAUTION

- Do not attempt to transport the inverter by the front of the cover. Securely hold the inverter by the heat-sink mounting chassis to prevent the inverter from falling, this may cause personnel injury or damage to the inverter itself.
- Install the inverter onto a firm metal base plate or another non-flammable type material. Do not install the inverter onto or nearby any flammable material.
- An additional cooling fan may need to be installed if several inverters are installed into one control panel. The inside temperature inside an enclosed panel should be below 40 degrees to avoid overheating.
- Turn off the power supply before proceeding to remove or perform any work on any panel. Carry out installation procedures according to instructions given in order to avoid a situation resulting in an operational malfunction.
- Suitable for use on a circuit capable of delivering not more than 5000 RMS symmetrical amperes. 240 Volts maximum.
- This product is not provided with over speed protection.
- Only intended for use in a pollution degree 2 macro environment or equivalent

When power is applied

⚠ WARNING

- Do not attempt to install or remove input or output connectors of inverter when the power supply is turned on. Otherwise, the inverter may be damaged due to the surge peak caused by the insertion or removal of power.
- When momentary power loss is longer than 2 seconds (the larger of horse power, the longer of time), the inverter does not have enough storage power to control the circuit; Therefore, when power is regenerated, the operation of the inverter is based on the setup of F_10 and the condition of external switch, this is considered to be 「restart」 in the following paragraphs.
- When the momentary power loss is short, the inverter still has enough storage power to control the circuit; therefore, when power is regenerated, the inverter will automatically start operation again depends on the setup of F_23.
When restart the inverter, the operation of the inverter is based on the setup of F_10 and the condition of external switch (FWD/REV button). Attention: the restart operation is irrelevant with F_23/F_24.
 - (1) When F_10=0, the inverter will not start after restart.
 - (2) When F_10=1 and the external switch (FWD/REV button) is OFF, the inverter will not start after restart.
 - (3) When F_10=1 and the external switch (FWD/REV button) is ON, the inverter will start automatically after restart. Attention: Base on safety reason, please turn off the external switch (FWD/REV button) after power loss to avoid possible damage to the machine and the human body after sudden regeneration of power.

Under Operation

WARNING

Do not use a separate device to switch ON or OFF motor during operation. Otherwise, the inverter may experience an over-current breakdown.

WARNING

- Do not remove the front cover of the inverter when the power is ON to avoid personnel injury caused by electrical shock.
- When the automatic restart function is enabled, the motor and machinery will be restarted automatically.

CAUTION

- Do not touch the heat-sink base during operation.
- The inverter can be easily operated from a low-speed to high-speed range. Please reconfirm the operating range of motor and the machinery you are controlling.
- Do not examine the signals on the PCB of the inverter when it is under operation.
- All inverters are properly adjusted and set before delivery.

CAUTION

Do not proceed with disassemble or examination procedure before ensuring that the power is off and the Power LED extinguished.

When performing an examination or maintenance

CAUTION

Inverter environment should be within temp: $-10^{\circ}\text{C} \sim +40^{\circ}\text{C}$, humidity under 95% RH without condensing.

CAUTION

After the removal of shield sticker, the environment temperature should be within $-10^{\circ}\text{C} \sim +50^{\circ}\text{C}$ and humidity under 95% RH without condensing. Besides, the inverter should be free from water dripping or metal dust.

2. Precautions of operation environment

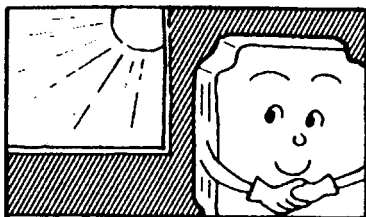

Avoid any direct sunlight

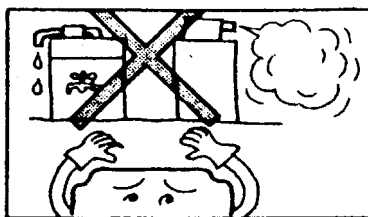

Keep away from corrosive gas or liquid

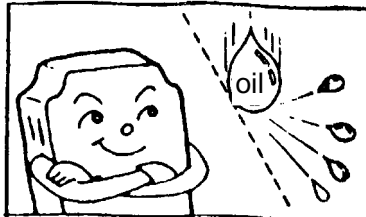

Keep away from oil grease and gas

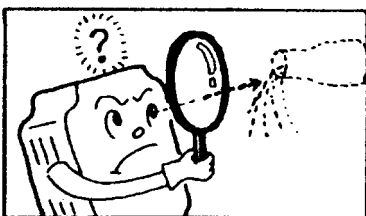

Keep away from salty environments



Keep away from rain or where dripping water may get into the inverter

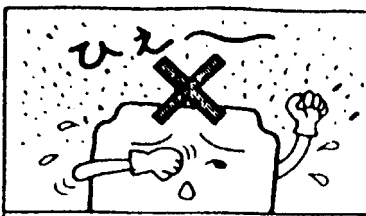

Avoid metal dust and dusty environments

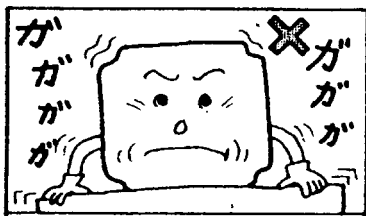

Avoid massive vibration

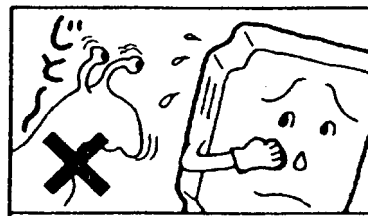

Avoid excessive direct heat

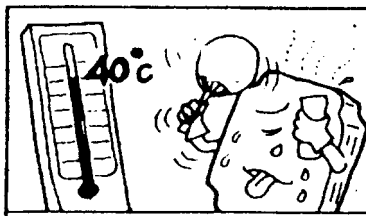

Avoid where environmental temperatures are too high

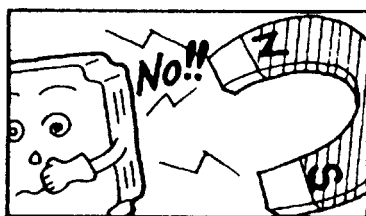

Keep away from high electrical-magnetic waves or ultra-high waves.

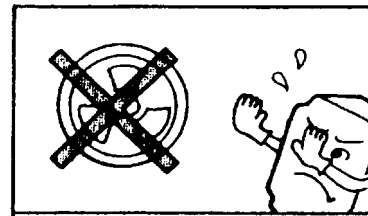

Keep away from radioactive matter

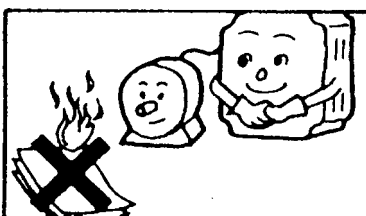

Keep away from flammable material

Chapter 2: Hardware Instructions and Installation

1. Operational Environment

The installation site of the inverter is very important. It relates directly to the functionality and the life span of your inverter. Please carefully choose the installation site to meet the following requirements:

- Mount the unit vertically
- Environment temperature: $-10^{\circ}\text{C} \sim +40^{\circ}\text{C}$ (without shield sticker: $-10^{\circ}\text{C} \sim +50^{\circ}\text{C}$)
- Avoid placing close to any heating equipment
- Avoid water dripping or humid environment
- Avoid direct sunlight
- Avoid oil or salty corrosive gas
- Avoid contacting corrosive liquid or gas
- Prevent foreign dusts, flocks, or metal scraps from entering interior
- Avoid electric-magnetic interference (soldering or power machinery)
- Avoid vibration, if vibration cannot be avoided, an anti-rattle mounting device should be installed to reduce vibration.
- If the inverter is installed in an enclosed control panel, please remove the shield sticker located at the top of the inverter. This will allow additional airflow and cooling.

External Fan Placement needs to be over the top of the inverter

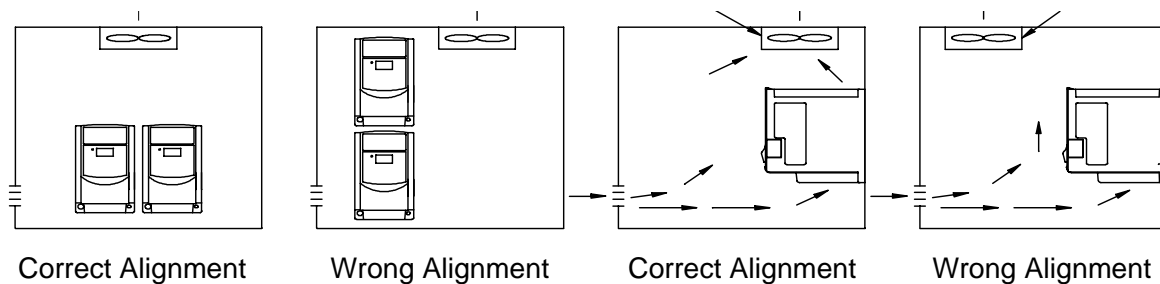

- For proper Installation of the inverter you must place the front side of the inverter facing front and the top of the inverter in the up direction for better heat dissipation.
- Installation must be compliant to the following requirements.

3.Specification:

Basic specification:

Model : E2-		1P2-H1x	1P5-H1x	101
Suitable Motor Power Rating (KW)		0.2	0.4	0.75
Rated	Motor (HP)	1/4	1/2	1
	Output Current (A)	1.4	2.3	4.2
	Capacity (KVA)	0.53	0.88	1.6
	Weight (Kg)	0.7	0.72	0.8
Input Voltage Max.		Single phase 100-120V (+10%, -15%), 50 / 60Hz (+/-5%)		
Output Voltage Max.		Three phases 200-240V (Proportional to input voltage)		
Dimension W*H*D (mm)		72*132*118		
EMC Specification		Without Filter		

Model: E2-		2P2-x1xx	2P5-x1xx	201-x1xx	202-Hxxx	203-Hxxx
Suitable Motor Power Rating (KW)		0.2	0.4	0.75	1.5	2.2
Rated	Motor (HP)	0.25	0.5	1	2	3
	Output Current (A)	1.4	2.3	4.2	7.5	10.5
	Capacity (KVA)	0.53	0.88	1.6	2.9	4.0
	Weight (Kg)	0.76	0.77	0.8	1.66	1.76
Input Voltage Max.		Single/Three phases 200-240V (+10%, -15%), 50 / 60Hz (+/-5%)				
Output Voltage Max.		Three phases 200-240V (Proportional to input voltage)				
Dimension W*H*D (mm)		72*132*118			118*143*172	
EMC Specification		Class A (Single Phase Filter built in)				

Model : E2-		401-H3xx	402-H3xx	403-H3xx
Suitable Motor Power Rating (KW)		0.75	1.5	2.2
Rated	Motor (HP)	1	2	3
	Output Current (A)	2.3	3.8	5.2
	Capacity (KVA)	1.7	2.9	4.0
	Weight (Kg)	1.6	1.62	1.68
Input Voltage Max.		Three phases 380-480V (+10%, -15%), 50 / 60Hz (+/-5%)		
Output Voltage Max.		Three phases 380-480V (Proportional to input voltage)		
Dimension W*H*D (mm)		118*143*172		
EMC Specification		Class A (Three Phases Filter built in)		

Functional specification:

Item		Specification
Input Signal Type		PNP type (SOURCE) input (External 24VDC Input is allowed)
Control Method		Sinusoidal wave PWM control
Freq. Control	Freq. Range	1~200 Hz*1
	Resolution Setting	Digital: 0.1 Hz (1 ~ 99.9 Hz); 1 Hz (100 ~ 200 Hz) Analog: 1Hz/ 60 Hz
	Keyboard Setting	Directly setup by buttons.
	External Signal Setting	0~10V, 4 ~ 20mA, 0 ~ 20mA
	Other function	Frequency upper and lower limit
General Control	Carrier frequency	4~16KHz*2
	Accelerate/Decelerate time	0.1~ 999 Sec
	V/F Pattern	6 Patterns
	Torque control	Torque boost level adjustable (manual torque boost)
	Multi-Functional input	2 point, to be used as multi-speed 1(Sp.1) / multi-speed 2(Sp.2) *1/ Jog / External emergency stop / External bb / Reset
	Multi-Functional output	1a Relay terminal, to be setup as Fault / Running / Frequency.
	Braking Torque	1P2~101/2P2~201:About 20% 202/203/401/402/403: 20%~100%, built-in braking transistor
Other function	Decelerate or free run stop, Auto reset, DC braking frequency / Voltage / Time can be setup by constants.	
Display		Three digital LED display frequency / inverter parameter / fault record / program version.
Operating temperature		-10 ~ +40°C (without shield sticker: -10°C ~ +50°C)
Humidity		0~95% RH non-condensing.
Vibration		Under 1 G (9.8 m/s ²)
EMC specification		EN5008-1, EN5008-2, EN50082-1, EN50082-2, EN50178
UL		UL508C
Protection Function	Overload protection	150% for 1 min.
	Over-voltage	DC voltage > 410V(100/200 series); DC voltage > 800V(400 series)
	Under voltage	DC voltage < 200V(100/200 series); DC voltage < 400V(400 series)
	Momentary Power-loss	0 ~ 2 sec: The inverter can be restarted using speed search feature.
	Stall Prevention	During Acceleration / Deceleration/ Constant speed
	Output Short-circuit	Electronic circuitry protection
	Grounding fault	Electronic circuitry protection
	Other function	Heat sink overheat protection, Current limit
Installation		Mounting screw or DIN rail (Option).

Note: *1: New function for CPU version v1.9 and above.

*2: Carrier frequency range: CPU version v1.6 is 4~8kHz.

CPU version v1.9 and above are 4~16kHz.

■ Suitable optional and Wiring Specification

Molded-Case Circuit Breaker / Magnetic Contact

- **Warranty does not apply to damage caused by the following situations:**

- (1) Damage to the inverter caused by the lack of appropriate molded-case circuit breaker or when a circuit breaker with too large of capacity is installed between the power supply and the inverter.
- (2) Damage to the inverter caused by the magnetic contact, phase advancing capacitor, or surge-protector installed between the inverter and the motor.

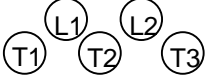
Model Type	1P2/1P5/2P2/2P5	101/201/202	203	401/402/403
Molded-case circuit breaker	15A	20A	30A	15A
Primary Circuit Terminal (TM1) 	Wire dimension (#14AWG) 2.0mm ² Terminal screw M3	Wire dimension (#14AWG) 2.0m m ² Terminal screw M3/M4	Wire dimension 3.5mm ² Terminal screw M4	Wire dimension 3.5mm ² Terminal screw M4
Signal Terminal (TM2) 1~11	Wire dimension 0.75mm ² (#18 AWG), Terminal screw M3			

Use copper conductors only size field wiring based on 80 degrees C wire only.

- **Please utilize three-phase squirrel-cage induction motor with appropriate capacity.**
- **If the inverter is used to drive more than one motor, the total capacity must be smaller than the capacity of the inverter. Additional thermal overload relays must be installed in front of each motor. Use the Fn_18 at 1.0 times of the rated value specified on the motor nameplate at 50Hz, 1.1 times of the rated value specified on the motor nameplate at 60Hz.**
- **Do not install phase advancing capacitors, LC, or RC component between the inverter and the motor.**

Application and precautions of Peripherals

From the Power Source:

- Apply the power source at the correct rated voltage to prevent from damaging the inverter.
- A Power Disconnect or Circuit breaker must be installed between the AC power supply and the inverter.

Molded-case circuit breaker:

- Utilize an appropriate circuit breaker that's suitable for the rated voltage and current ratings of the inverter to switch ON/OFF the power supply to the inverter and as additional protection for the inverter.
- Do not operate the circuit breaker to switch ON or OFF the inverter. The circuit breaker should be used only to supply input power and should not be used for operational sequence.

Leakage circuit breaker:

- An earth leakage circuit breaker should be added to prevent false operation cause by leakage current and to ensure personnel safety.

Magnetic Contact:

- The Magnetic Contact can be omitted at ordinary operation. To utilize external control, automatic restart, or breaking controller the magnetic contact must be added at the primary side.
- Do not operate the magnetic contact to switch ON or OFF the inverter.

Power improvement AC Reactor:

- If large capacity power source is applied (over 600KVA), additional AC reactor may be added to improve power factor.

Inverter:

- Power supply input terminals L1 and L2 are not differentiated on phase sequence. They can be arbitrarily connected. Their connection may be interchanged.
- Output terminal T1, T2, and T3 should be connected to the U, V, and W terminals of the motor respectively. If motor turns in opposite direction of the inverter command, simply exchanging two of the three wire connections will correct this problem.
- Output terminal T1, T2, and T3 must not be connected to power source to prevent from damaging the inverter.
- Grounding terminal properly ground the grounding terminal in compliance to 200V class type three grounding. (The 400V class type is special grounding.)

External wiring should be carried out in accordance with following requirement. Check and reassure the wiring is correct after the wiring is complete.

(Do not utilize the control circuitry buzzer to check the wiring.)

EMI connections:

It is very important that the connections between the inverter, the shielded motor cable, and the EMI filters are tested as follows.

- Use a metal grounding plate and place the frequency inverter and the EMI filter on the plate.
- Use a shielded motor cable with 4 connectors (U, V, W, & Earth), don't use the shielding as safety earth (shield is high frequency earth)
- Remove any paint around the two metal coupling nut holes. So that the metal coupling nuts (and the shielding) make contact with the frequency inverter and the motor.
- Don't solder a conductor to the shielding.
- Use a metal clamp to connect the shielding from the motor cable with the metal grounding plate. Now there is a perfect high frequency earth connection between frequency inverter, grounding plate and EMI filter.
- Keep the distance between the frequency inverter and EMI filter as short as possible (< 30cm) if longer use a shielded cable with a metal coupling nut and a metal clamp to connect the shielded cable to the frequency inverter and metal grounding plate.
- The only earth connection between the LISN and the test plate should be via the EMI filter.
- Use a motor which equals the power rating or below of the inverter rating.
- Install a noise filter for inverter onto the output side of the primary circuitry can suppress conducting noise.

Class B:

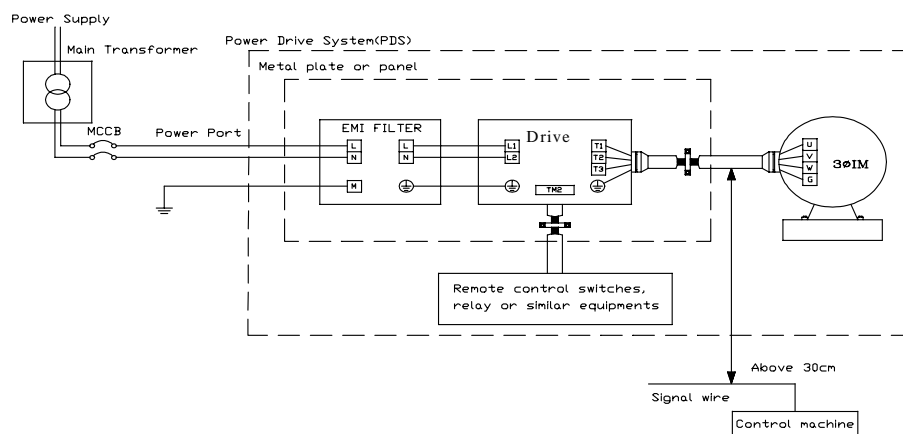

Class A:

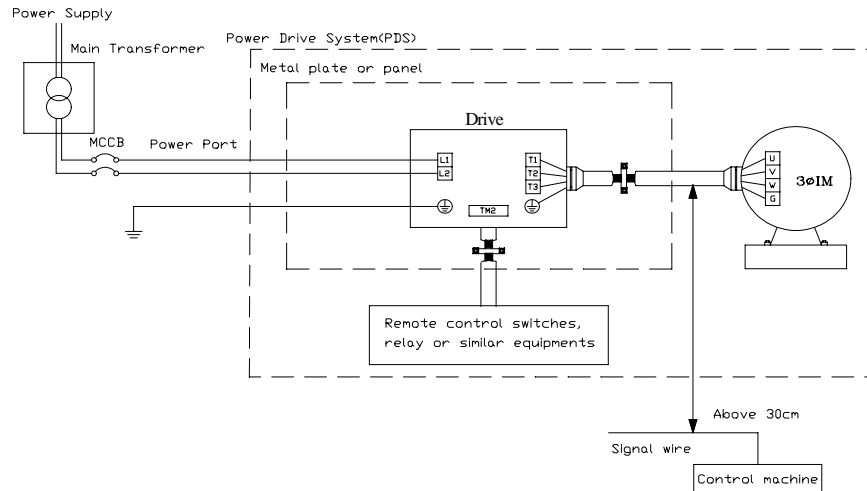

When the distance between the inverter and motor is longer than 100 meters, cable wire should be carefully chosen to reduce the wiring resistance below 3% and the voltage drop $(V) = 3 \times \text{Wire resistance} (\text{ } / \text{km}) \times \text{wire length (m)} \times \text{current} \times 10^{-3}$

- (B) Control circuitry wiring must be separated terminated and away from the primary power circuitry and other high-voltage or large-current power lines to avoid noise interference.
- To reduce the noise interference and avoid possible operational problems, shielded twisted pair cable should be used to wire the control circuitry. Please refer to following diagram. Connect the shielding wire onto the grounding terminal. Only connect one end of the shield.

Wiring distance must be under 50m.

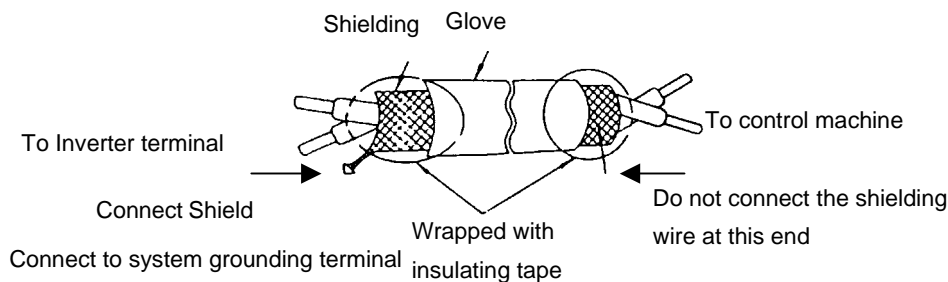

- (C) The grounding terminal of the inverter must be correctly grounded in compliance with 200V class type three grounding.
- Grounding wire should be wired in accordance to electrical equipment (AWG) with the length of the grounding wire as short as possible.
- The grounding wire of the inverter must not be grounded together with other large current loads (such as soldering machines or large current motors). They should be grounded separately.

- Grounding circuitry must not be formed when grounding several inverters together.

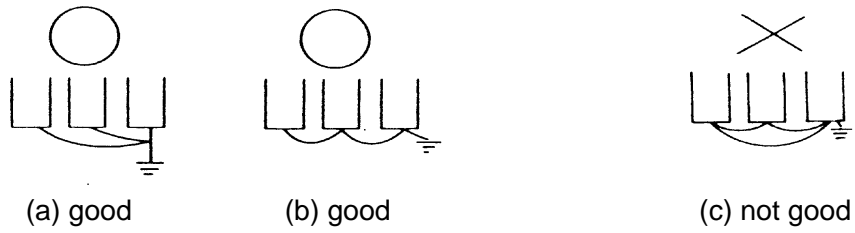

(D) Wire specification, apply appropriate wire with correct diameter for primary power circuitry and control circuitry in accordance with electricity regulations.

Wiring Diagram

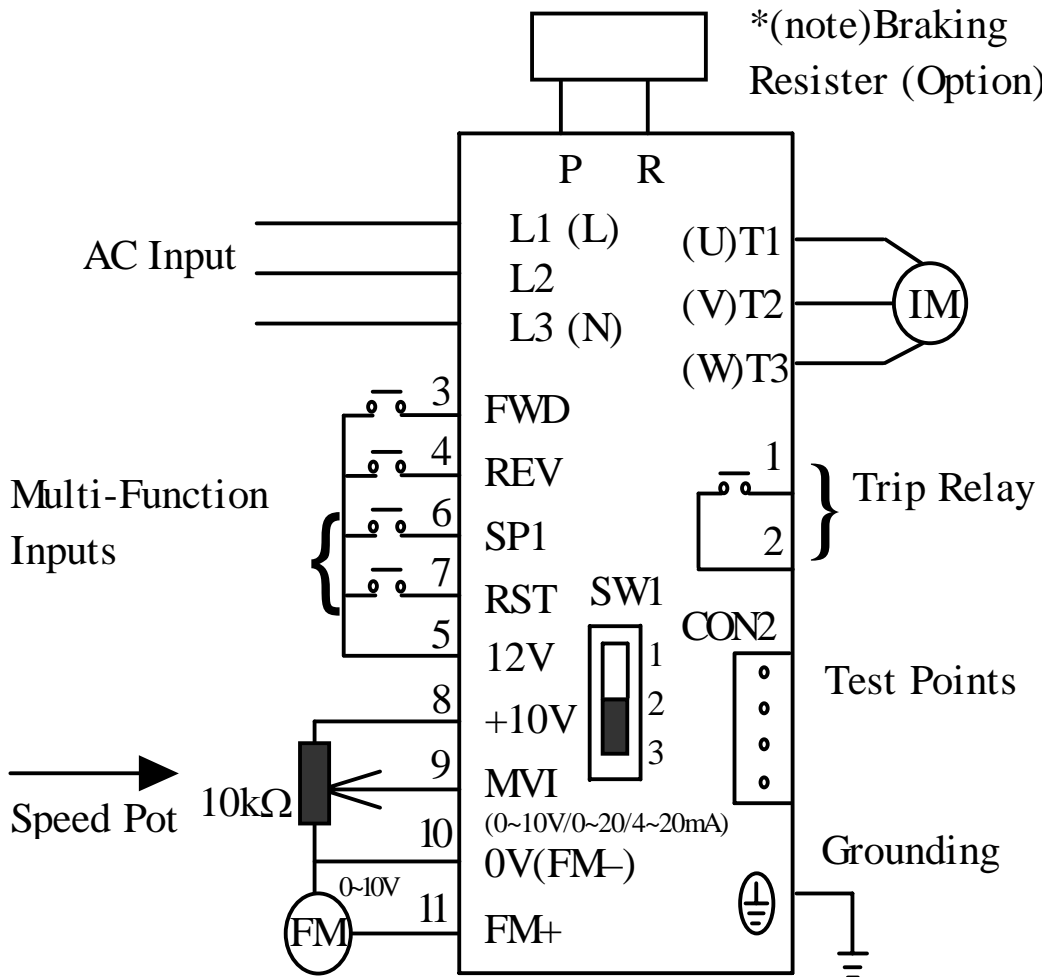

Wire Terminations to the Inverter must be made with either UL listed field wiring lugs or UL listed crimp type ring terminals.

Note: Only for 202/203/401/402/403.

- (External 24V supply)

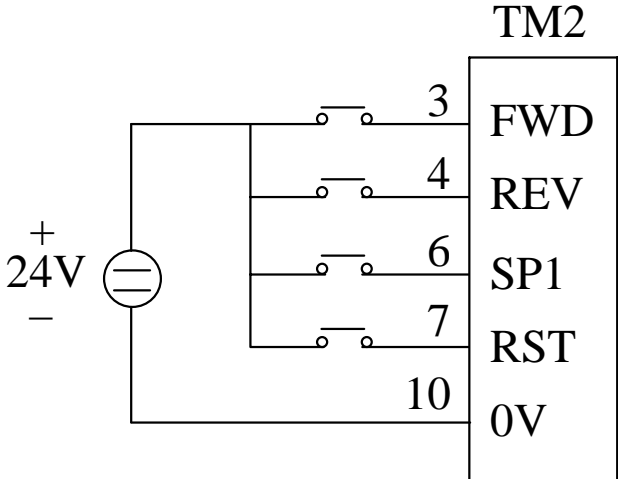

Inverter terminal descriptions

Primary Circuitry Terminal Block (TM1) descriptions

Terminal Symbol	Function Description
L1/L (R)	Primary power source input to Drive Single phase: L1/L2 or L/N Three phase: L1/L2/L3
L2 (S)	
L3/N (T)	
P	External braking resistor terminal (Only for E2-202/203/401/402/403)
R	
T1 (U)	Inverter output to Motor
T2 (V)	
T3 (W)	

Tightening torque for TM1 is 1 LBS-FT or 12 LBS-IN (1P2/1P5/2P2/2P5/201).

Tightening torque for TM1 is 1.3 LBS-FT or 16 LBS-IN (202/203/401/402/403).

* Wire voltage rating must be a minimum of 300V(200V series)/600V(400V series)

Control Circuitry Terminal Block (TM2) description

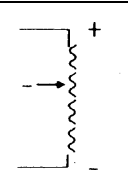
Terminal Symbol	Function Description	
1 TRIP	Fault relay output terminal & Multi function output terminal (refer to F_21)	
2 RELAY		
3 FWD (FW)	Operation control terminals (refer to F_03)	
4 REV (RE)		
5 + 12V(12)	Common point of terminal 3 / 4 / 6 / 7	
6 SP1(SP)	Multifunction input terminals (refer to F_19)	
7 RESET(RS)		
8 	+10V	Power terminal for potentiometer (Pin 3)
9	Analog input wire Wiper	Analog frequency signal input terminal (Pin 2 of potentiometer or positive terminal of 0~10V / 4~20mA / 0~20mA)
10 0V(FM -)	Analog common point	Analog signal common point (Pin 1 of potentiometer or negative terminal of 0~10V / 4~20mA / 0~20mA)
11 FM+	Analog output positive connection point	Analog frequency signal output terminal Output terminal signal is 0 ~ 10VDC/Fn6

Tightening torque for TM2 is 0.42 LBS-FT or 5.03 LBS-IN.

* Wire voltage rating must be a minimum of 300V

* Control wiring should not run in the same conduit or raceway with power or motor wiring

* Single Input and Output Terminals (TM2) Ratings are ALL Class 2

SW1 function description

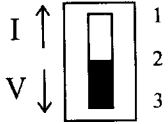
SWITCH 1	External signal type
	0~20mA analog signal (When F_11 is set to 1) 4~20mA analog signal (When F_11 is set to 2)
	0~10 VDC analog signal (When F_11 is set to 1)

Dimensions & Location of terminal block

E2-1P2/1P5/101/2P2/2P5/201:

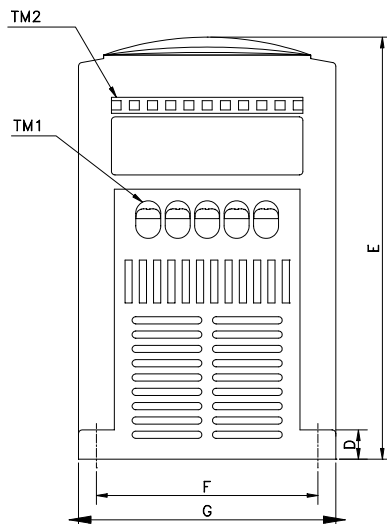
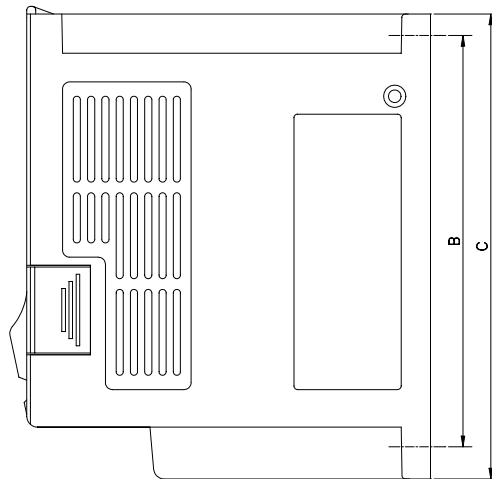
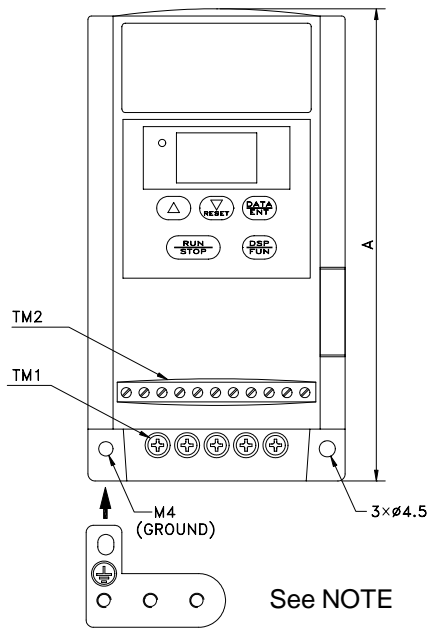

Unit: mm

DEMESIONS MODEL	A	B	C	D	E	F	G
E2-1P2/1P5/101/2P2/2P5/201	132	116	130	8.2	118	61	72

NOTE: For safety reason, we strongly recommend users to remove the M4 grounding screw, then screw the enclosed “metal frame grounding terminal” on the same location to make a grounding bar to ensure good earth protection.

E2-202/203/401/402/403:

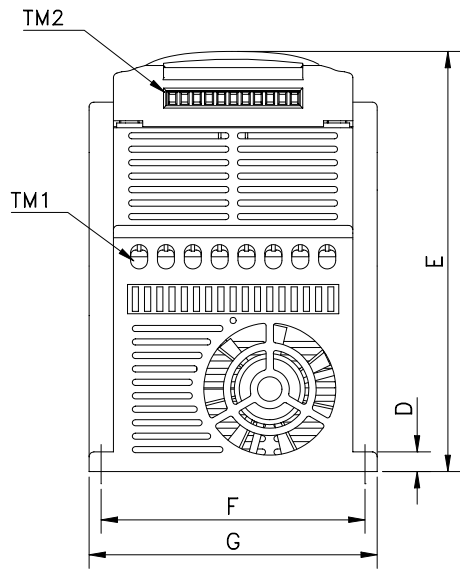
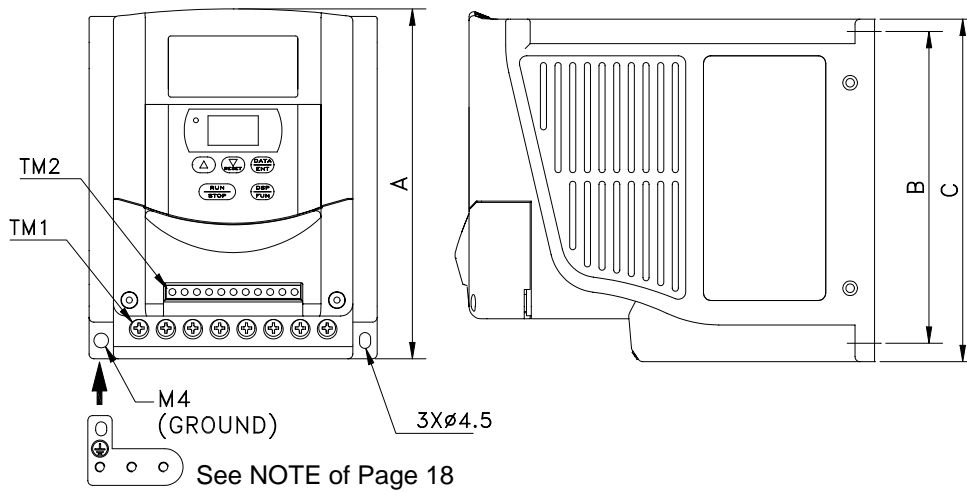

Unit:mm

MODEL	LENGTH	A	B	C	D
E2-202/203/401/402/403		143.1	127.5	140	8.0

MODEL	LENGTH	E	F	G
E2-202/203/401/402/403		171.7	108	118

Dimensions & Installation of class B Filter

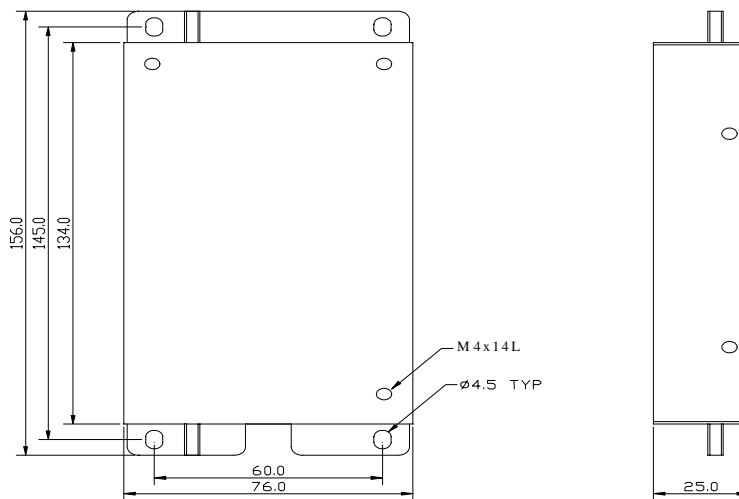

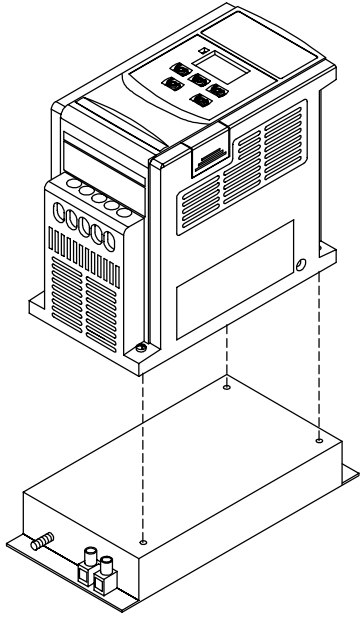

Inverter with class B filter mounted.

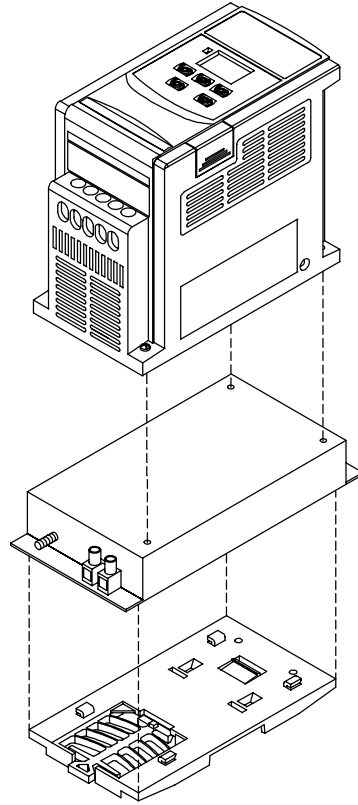

Inverter with class B filter & Din rail mounted kit.

Mounting Instructions

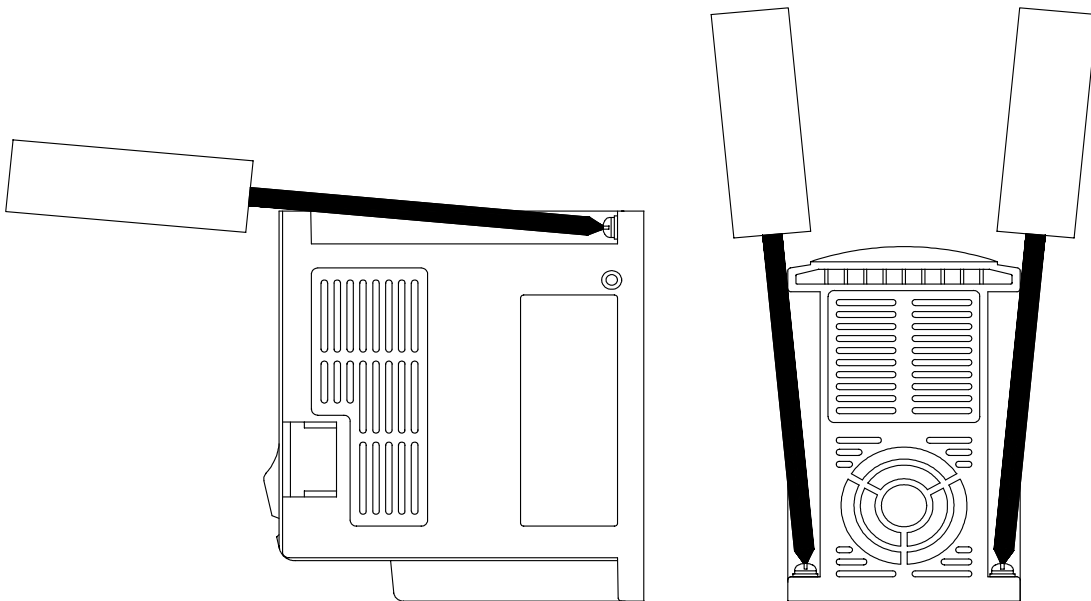

Din Rail Mounting Diagram

Step1- Aim and insert the 4 retention ribs of the DIN Rail at the 4 holes in rear panel of inverter

Step2- Push the DIN Rail forward until the middle rib grips firmly with back panel

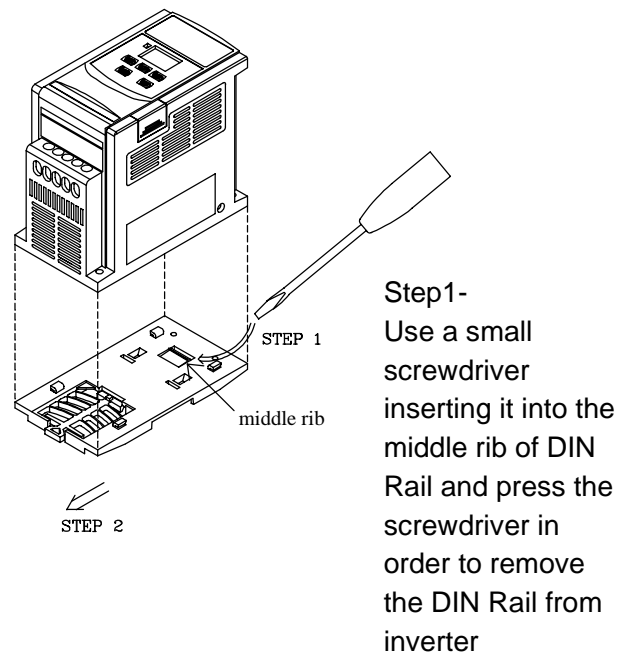
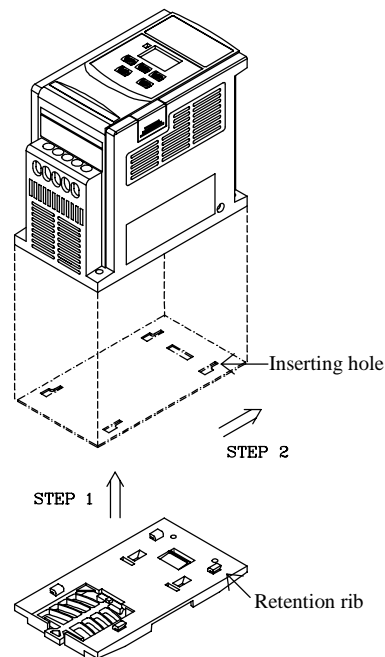

Step1- Use a small screwdriver inserting it into the middle rib of DIN Rail and press the screwdriver in order to remove the DIN Rail from inverter

Additional DIN Rail Installation

A mounting clamp and a 35mm width rail must be used to install the Drive on the rail.

Install Drive

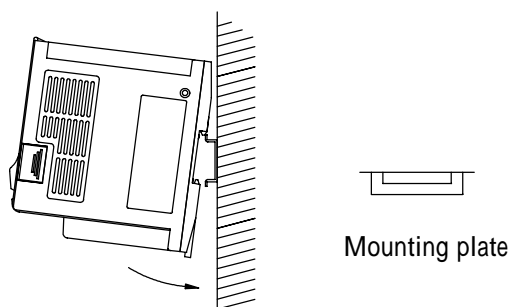

First place the groove on the back of module on the upper edge of din rail, and then push the module down to lock up position. Finally press the mounting plate upward into module.

Dismounting Drive

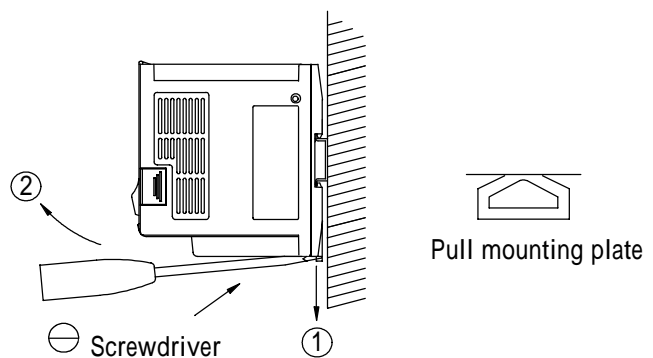

- ① Pull the mounting plate downward.
- ② Rotate the inverter module to dismount it.

E2-1P2/1P5/101/2P2/2P5/201- N4X (IP65)TYPE:

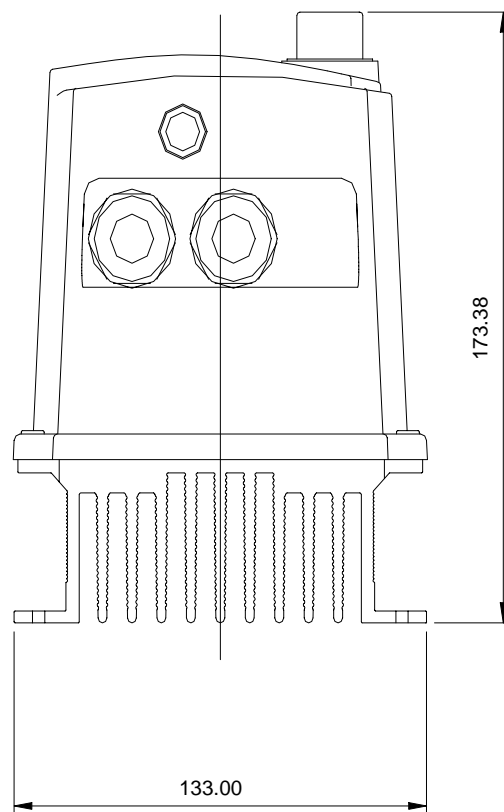
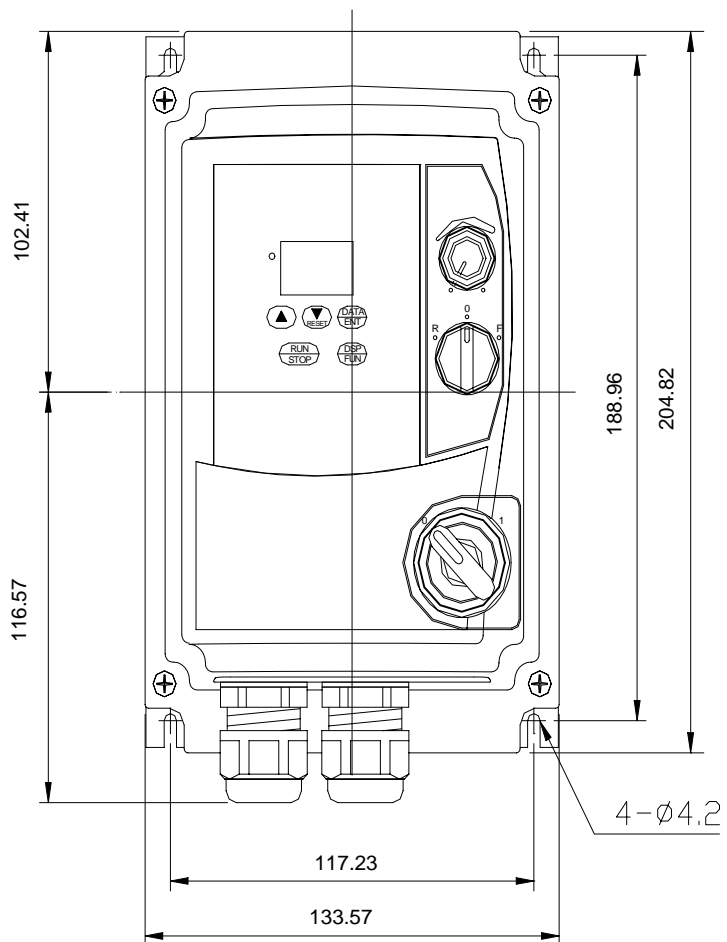

UNIT : mm

E2-202/203/401/402/403-N4X(IP65)TYPE:

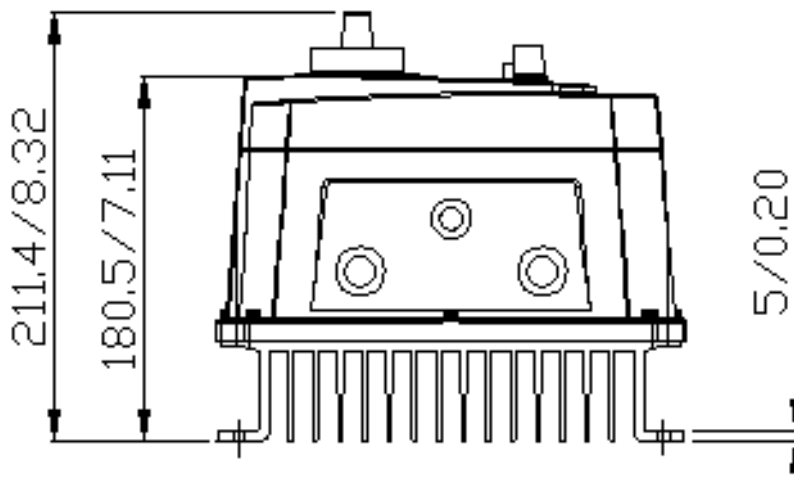
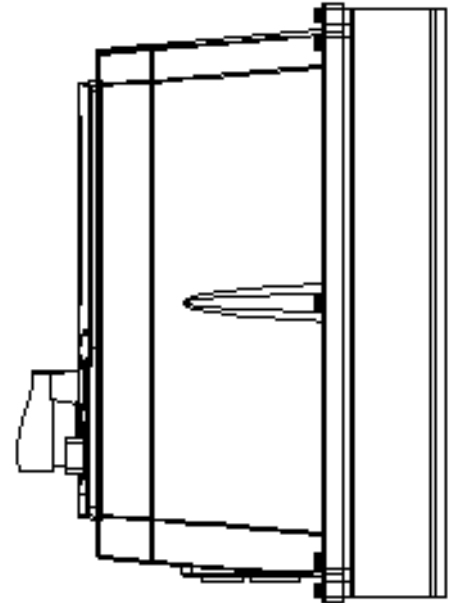
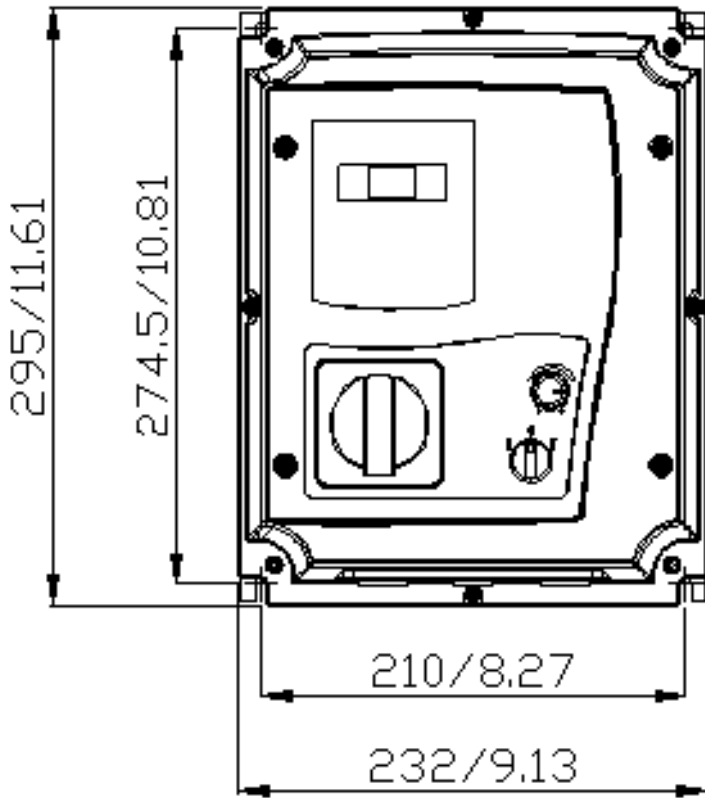

UNIT:mm/inch

E2-1P2/1P5/101/2P2/2P5/201- - N4X(IP65)TYPE INSTALLATION :

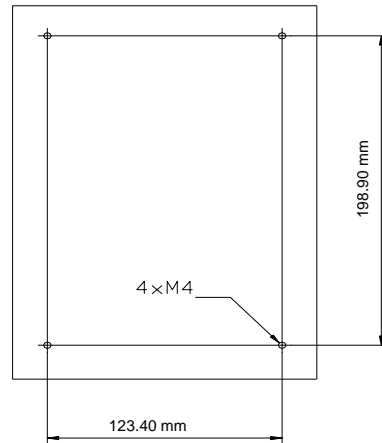
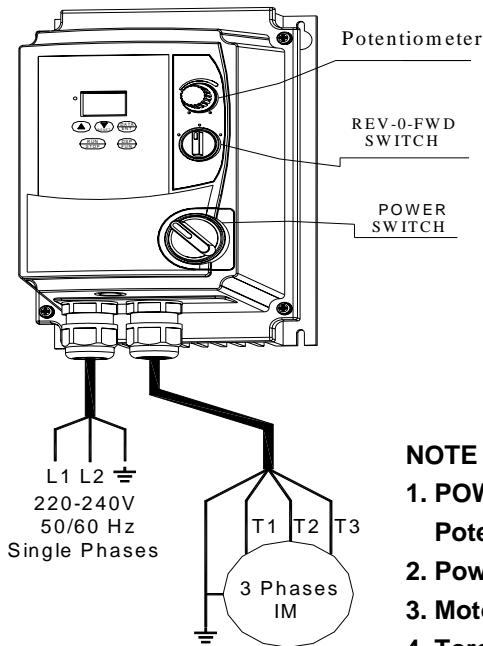

NOTE :

1. POWER SWITCH , REV-0-FWD SWITCH AND Potentiometer are only for E2-2P2~201- N4S TYPE
2. Power supply cable : #14 AGE (2.0mm²)
3. Motor cable : #16 AGE (1.25mm²)
4. Torque value of Screw :
 - (1). Power/Motor cable (plug in) Therminal : 5kg-cm(4.34 in-lb)
 - (2). Remote control wire : 4kg-cm(3.47 in-lb)
 - (3). Outer Cover (M4) : 6kg-cm(5.20 in-lb)

CIRCUIT DIAGRAM

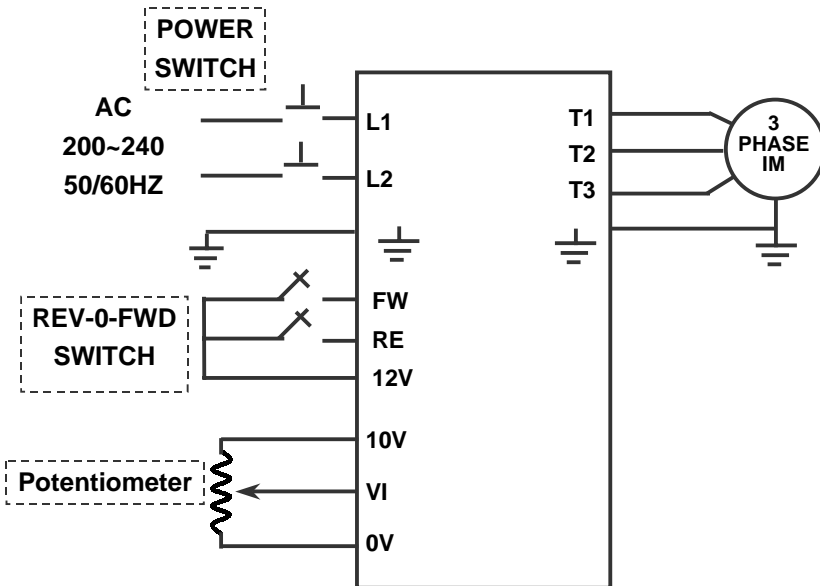

NOTE:

- (1). Input source : single-phase(L1,L2, \perp)ensuring that it is connected to a 200/240V supply.
- (2). Output Moter : three-phase(\perp ,T1,T2,T3).
- (3). POWER SWITCH , REV-0-FWD SWITCH AND Potentiometer are only for E2-2P2~201- N4S TYPE.

Caution :

Do not start or stop the inverter using the main circuit power.

FOR E2-2P2~201- -N4S TYPE :

Please always remain REV-0-FWD switch at 0 position. In order to keep inverter has no running signal before power-on again after power supply interrupted.Otherwise, injury may result.

FOR E2-2P2~201- -N4S TYPE :

Please always remain RE or FW switch at OFF position. In order to keep inverter has no running signal before power-on again after power supply interrupted.Otherwise, injury may result.

E2-2P2/2P5/201- -N4 (WITHOUT SWITCH TYPE) CONNECTIONS & EMC MOUNTING:

CONNECTIONS

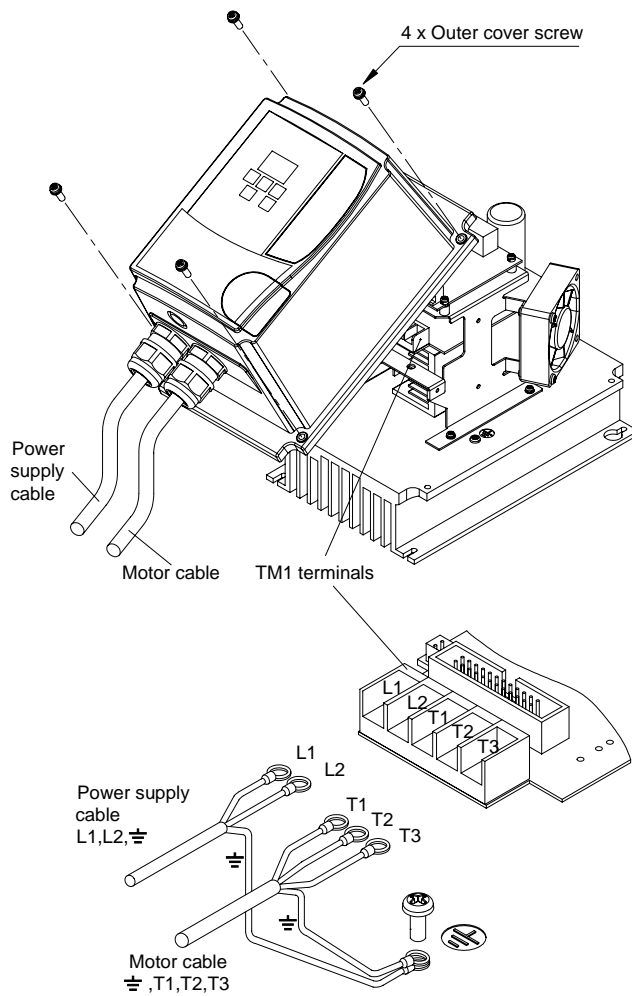

EMC MOUNTING

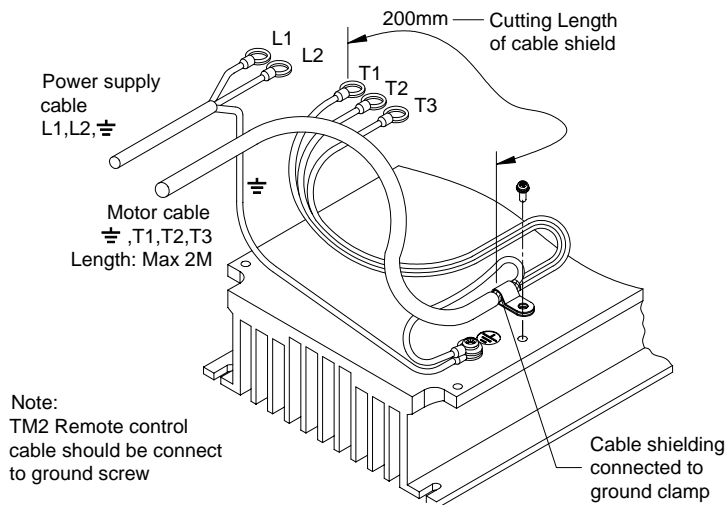

E2-2P2/2P5/201- -N4S (WITH SWITCH TYPE) EMC MOUNTING & CONNECTIONS :

CONNECTIONS

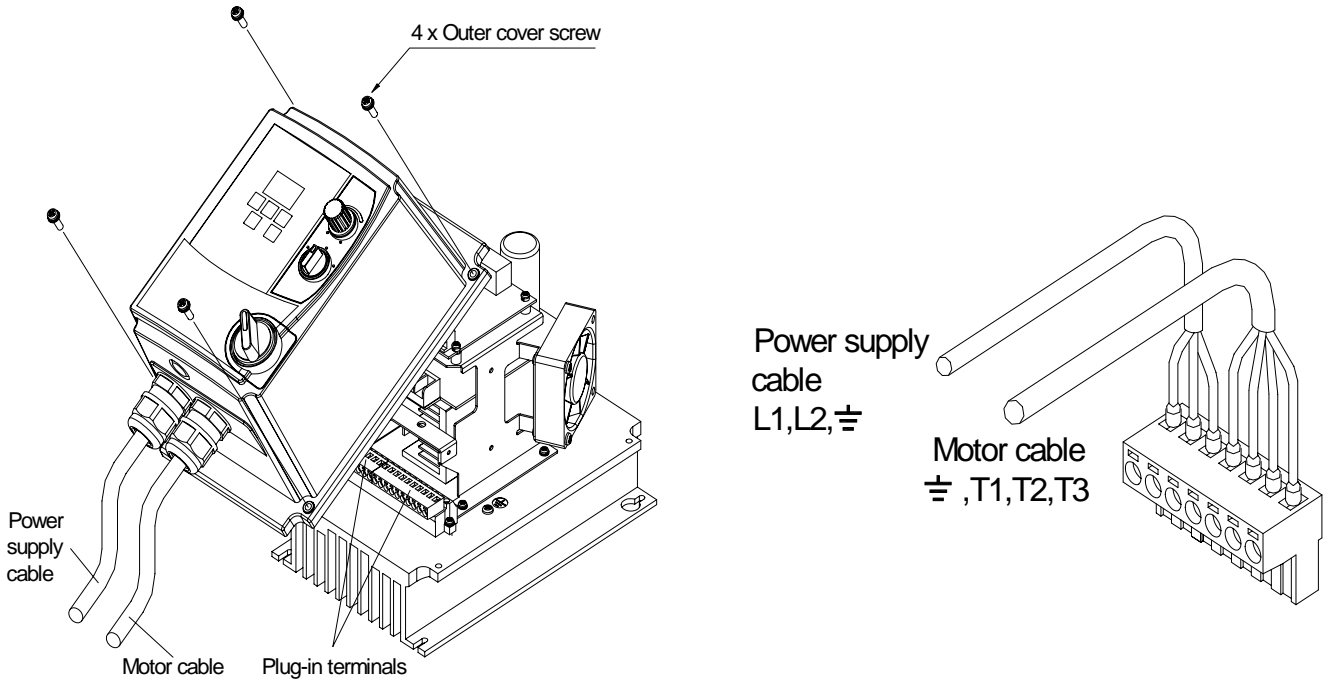

EMC MOUNTING

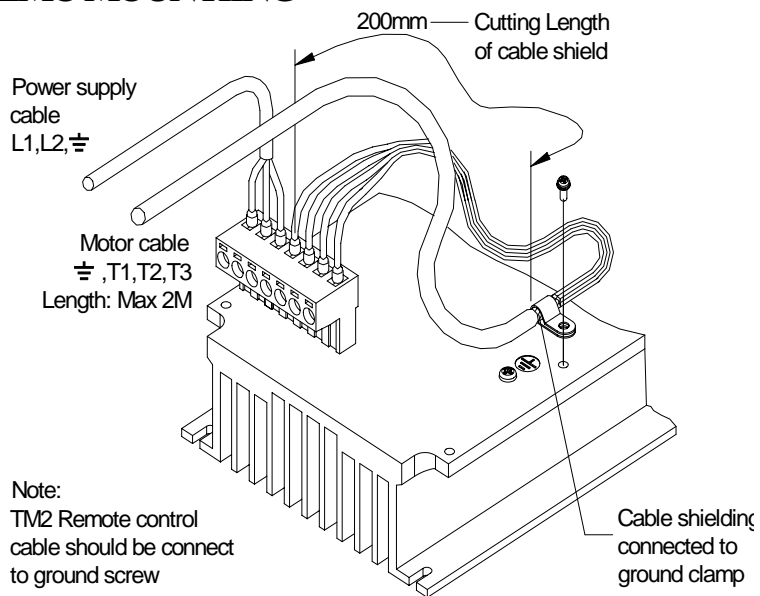

E2-202/203/401/402/403—N4X(IP65)TYPE INSTALLATION:

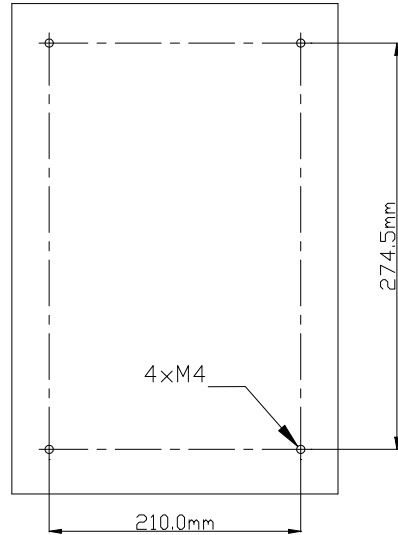
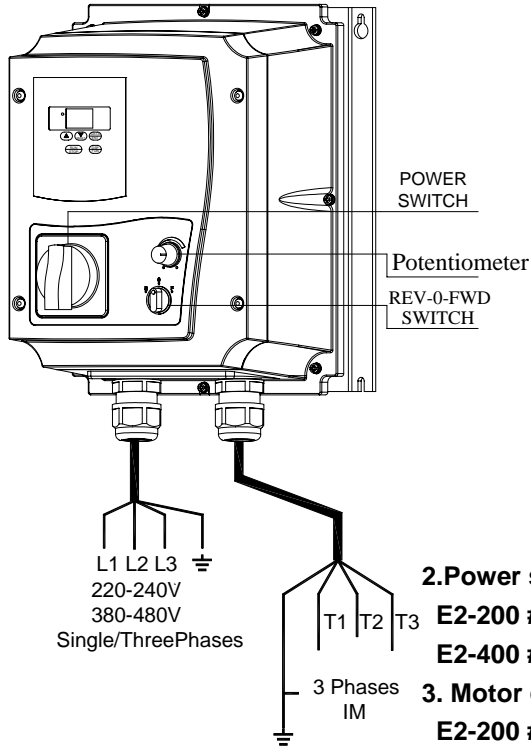

NOTE:

1. POWER SWITCH, REV-0-FWD SWITCH AND Potentiometer are only for E2-202~403-N4S TYPE

2. Power supply cable :

E2-200 #12AWG(3.5mm²)

E2-400 #16AWG(1.25mm²)

3. Motor cable :

E2-200 #14AWG(2.0mm²)

E2-400 #16AWG(1.25mm²)

4. Torque value of Screw :

(1). Power/Motor cable(TM1, TM3)

Terminal : 8 kgf-cm(6.94 in-lb)

(2). Remote control wire : 4 kgf-cm(3.47 in-lb)

(3). Outer Cover (M4) : 8kgf-cm(6.94 in-lb)

CIRCUIT DIAGRAM

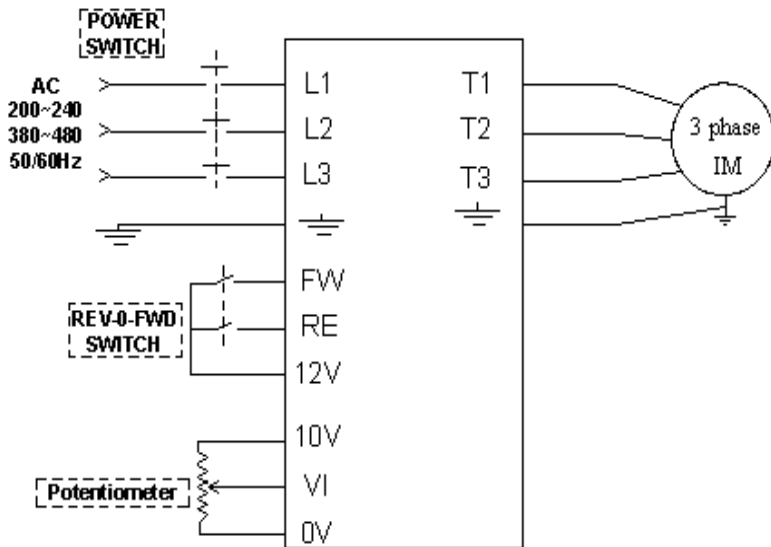

Caution:

. Do not start or stop the inverter using the main circuit power.

. FOR E2-202~403--N4S TYPE:

Please always remain REV-0-FWD switch at 0 position. In order to keep inverter has no running signal before power-on again after power supply interrupted. Otherwise, injury may result.

. FOR E2-202~403--N4 TYPE:

Please always remain RE-OR-FW switch at OFF position. In order to keep inverter has no running signal before power-on again after power supply interrupted. Otherwise, injury may result.

NOTE:

(1). Input source: single-phase(L1, L2, $\frac{1}{\text{G}}$) ensuring that it is connected to a 200/240 supply.

or three-phase(L1, L2, L3, $\frac{1}{\text{G}}$) ensuring that it is connected to a 200/240, 380/460V supply.

E2-202/203/401/402/403—N4S(WITH SWITCH TYPE)CONNECTIONS&EMC MOUNTING:

CONNECTION

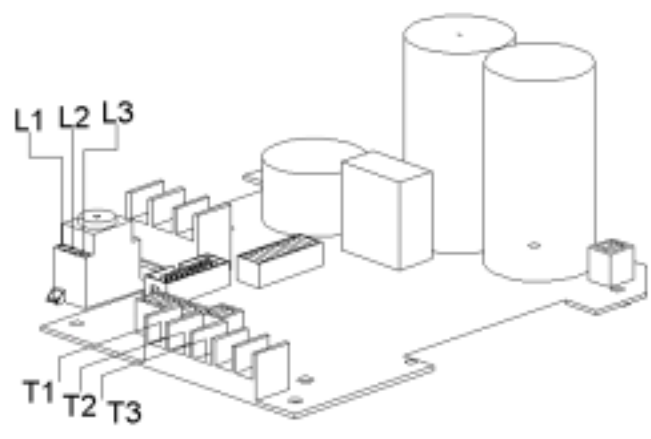
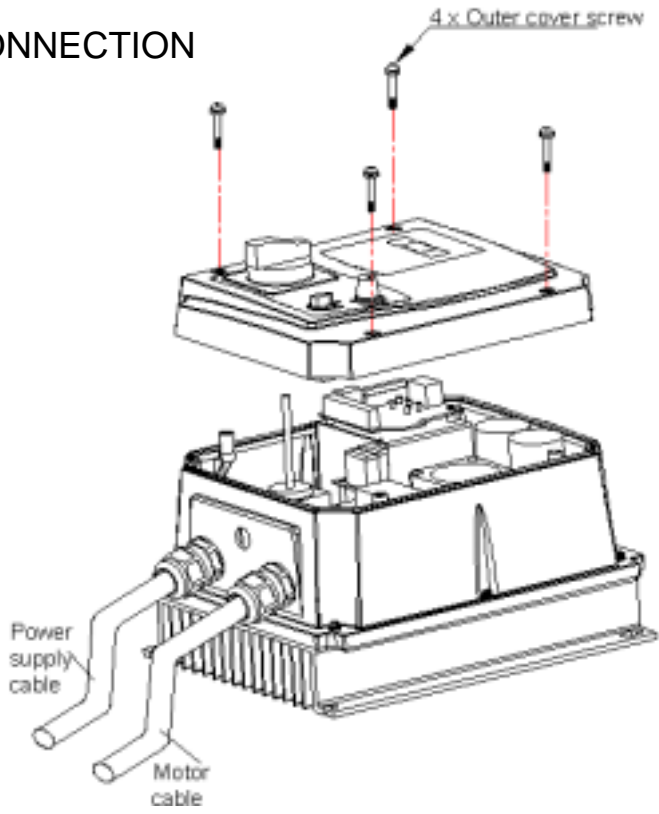

EMC MOUNTING

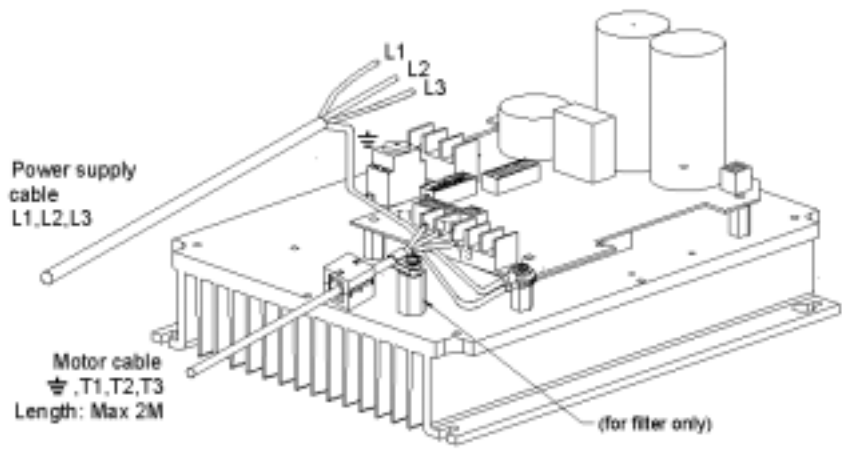

CONNECTION

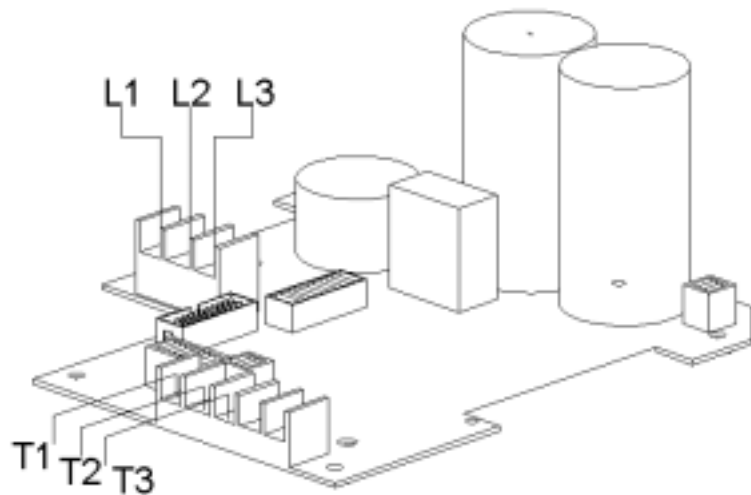
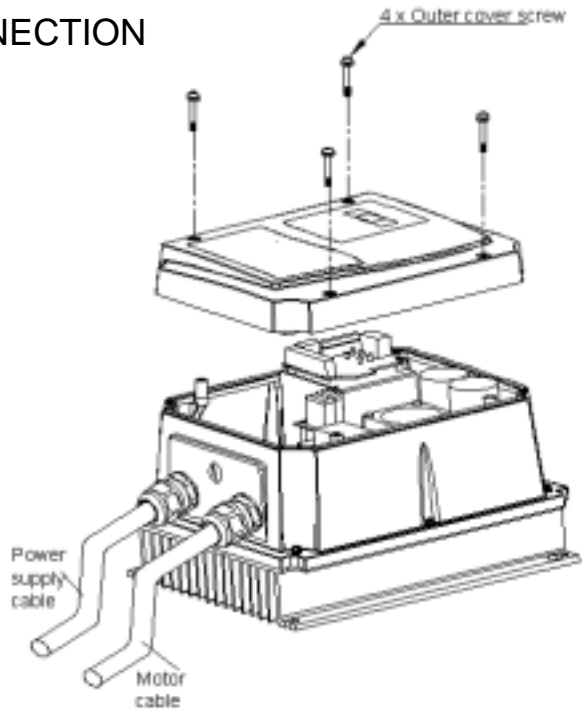

EMC MOUNTING

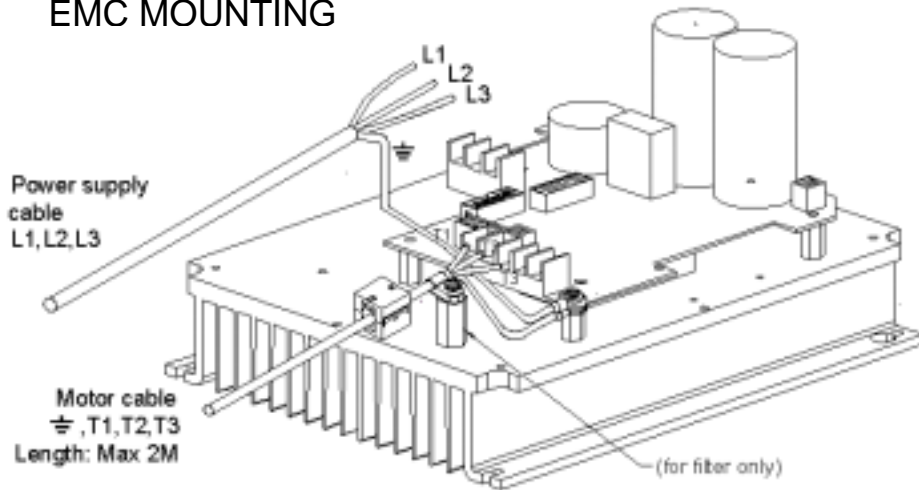

Chapter 3 Software Index

Keypad operating instructions

Keypad Description

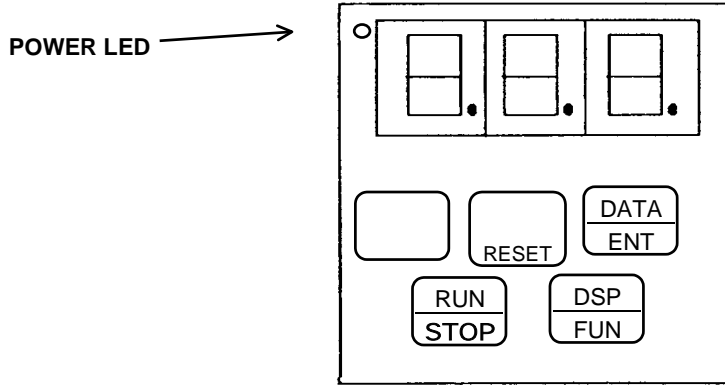

⚠ CAUTION

Do not operate keypad by screwdriver or other sharp-ended tool to avoid damaging keypad.

Brief keypad operation flowchart

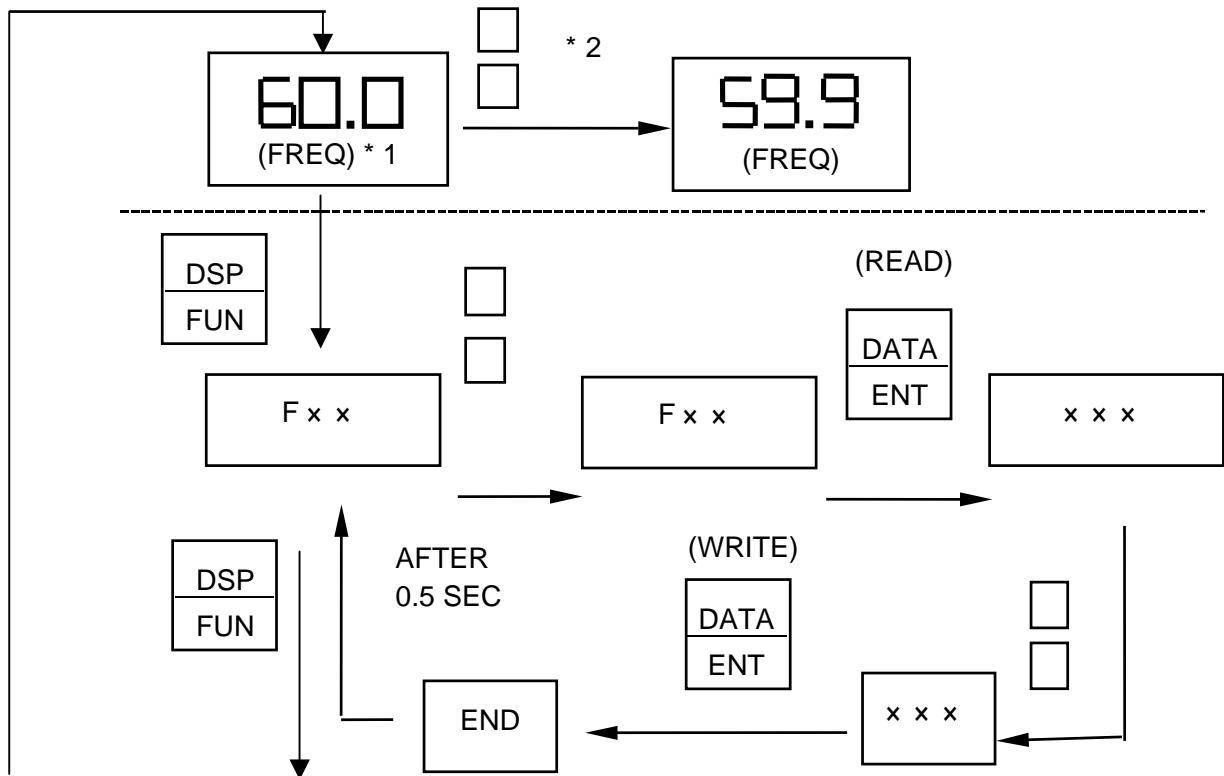

Note 1: Displayed setting of frequency when stopped. Display output frequency when running.

Note 2: The setting of the frequency can be modified either when stopped or when running.

Parameter List

Function	F_	Function Description	Unit	Range	Factory setting	Page	Note
	0	Factory Adjustment			0	24	
Accel. Time	1	Accel. time	0.1Sec	0.1 ~ 999 S	5.0	24	*1 *3
Decel. Time	2	Decel. time	0.1Sec	0.1 ~ 999 S	5.0	24	*1 *3
Operation mode	3	0: Forward / Stop, Reverse / Stop 1:Run/Stop, Forward / Reverse	1	0 ~ 1	0	25	
Motor rotation direction	4	0: Forward 1: Reverse	1	0 ~ 1	0	25	*1
V/F Pattern	5	V/F pattern setting	1	1 ~ 6	1/4	26	*2
Frequency upper/lower limit	6	Frequency upper limit	0.1Hz	1.0 ~ 120Hz (1~200)*4	50/60Hz	27	*2 *3
	7	Frequency lower limit	0.1Hz	0.0 ~ 120Hz (1~200)*4	0.0Hz	27	*3
SPI frequency	8	SP1 frequency	0.1Hz	1.0 ~ 120Hz (1~200)*4	10Hz	27	*3
JOG frequency	9	JOG frequency	0.1Hz	1.0 ~ 10.0Hz (1~200)*4	6Hz	27	
Start / Stop Control	10	0: Keypad 1: Terminal (TM2)	1	0 ~ 1	0	27	
Frequency Control	11	0: Keypad 1: Terminal (0~10v / 0~20mA) 2: Terminal (4~20mA)	1	0 ~ 2	0	28	
Carrier frequency control	12	Carrier Frequency Setting	1	1 ~ 5 (1~10)*4	5	28	
Torque compensation	13	Torque compensation gain	0.1%	0.0 ~ 10.0%	0.0%	28	*1
Stop method	14	0:controlled deceleration stop 1:free run to stop	1	0 ~ 1	0	29	
DC braking setting	15	DC braking time	0.1S	0.0 ~ 25.5S	0.5S	29	
	16	DC braking injection frequency	0.1Hz	1 ~ 10Hz	1.5Hz	29	
	17	DC braking level	0.1%	0.0 ~ 20.0%	8.0%	29	
Electronic thermal Overload protection	18	Protection base on motor rated current	1%	50 ~ 100% (0~200)*4	100%	30	
Multifunction input connection point	19	Multifunction input terminal 1 (SP1) function		1: Jog 2: Sp1 3: Emergency stop 4: External Base Block	2	31	
	20	Multifunction input terminal 2 (RESET) function		5: Reset 6: SP2*4	5	31	
Multi-function output	21	Multifunction output terminal		1: Operating 2: Frequency reached 3: Fault	3	32	

Function	F_	Function Description	Unit	Range	Factory setting	Page	Note
Reverse Lock-Out	22	0: REV run 1: REV run Lock-Out	1	0 ~ 1	0	32	
Momentary power loss	23	0: enabled 1: disabled	1	0 ~ 1	0	33	
Auto restart	24	Number of Auto-restart times	1	0 ~ 5	0	33	
Factory setting	25	010: Constants initialization to 50Hz system 020: Constants initialization to 60Hz system				34	*2
SP2 frequency	26	SP2 frequency	0.1Hz	1.0~200Hz	20	34	*4
SP3 frequency	27	SP3 frequency	0.1Hz	1.0~200Hz	30	34	*4
Direct start	28	0:enable 1:disable	1	0 ~ 1	1	34	*5
Software version	29	CPU program version				35	
Fault Log	30	Fault log for three faults.				35	

NOTE:

*1: Indicate this parameter can be adjusted during running mode.

*2: Please refer to F_25.

*3: If the setting range is above 100, the setting unit becomes 1.

*4: New function for CPU version V1.9 and above.

*5: New function for CPU version V2.1 and above

Parameter function description

F_00 Factory adjustment parameter. Do not change.

F_01 : Acceleration time = 0.1 ~ 999 sec

F_02 : Deceleration time = 0.1 ~ 999 sec

1. Acceleration / Deceleration time calculation formula:

$$\text{Accelerate time} = F_{01} \times \frac{\text{Setting Frequency}}{60 \text{ Hz}}$$

$$\text{Decelerate time} = F_{02} \times \frac{\text{Setting Frequency}}{60 \text{ Hz}}$$

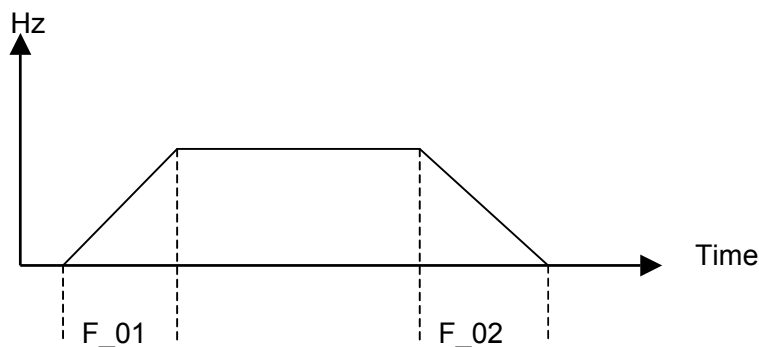

F_03: Operation mode selection =
0: Forward / Stop, Reverse / Stop
1: Run / Stop, Forward / Reverse

NOTE 1: F_03 takes effect only when F_10 = 1 (external operation control)

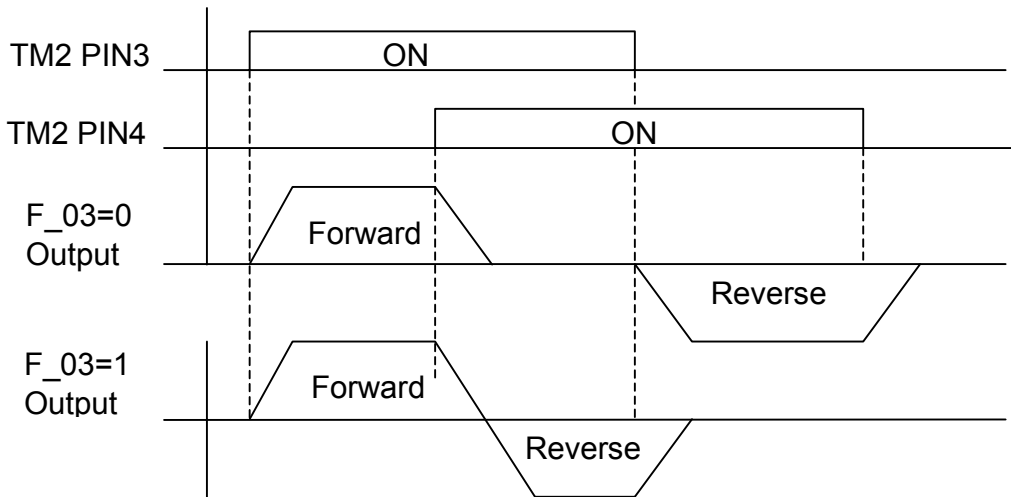
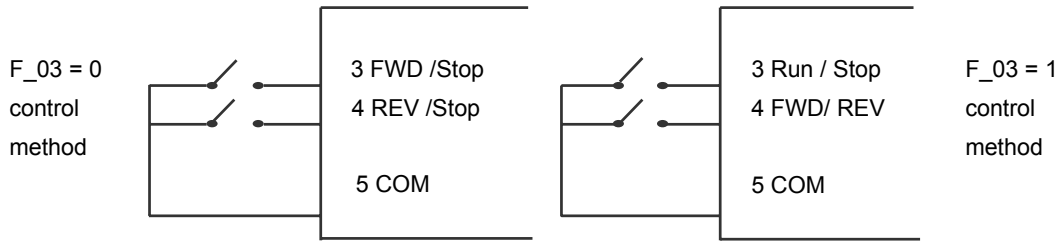

Note: Reverse command is ignored when F_22 = 1

F_04: Motor rotation direction setting = 0: Forward
1: Reverse

Although there is no Forward / Reverse push button on the digital control panel, it is possible to adjust forward / reverse function by changing the F_04 setting.

NOTE:

When F_22 =1: Reverse is disabled, the F_04 cannot be set to 1.

The keypad indication would display “LOC”.

F_05: V/F pattern setting = 1 ~ 6

Selecting F_05 = 1-6 to select one of the six preset V/F patterns. (Refer to the following tables)

Specification	50 Hz System		
Application	General Application	High starting torque	Decreasing torque
F_5	1	2	3
V/F pattern			
Specification	60Hz System		
Application	General Application	High starting torque	Decreasing torque
F_5	4	5	6
V/F pattern			

F_5	B	C
1/4	10%	8%
2/5	15%	10.5%
3/6	25%	7.7%

F_06: frequency upper limit range=1~120Hz
F_07: frequency lower limit range=1~120Hz
(1~200Hz with CPU version v1.9 and above)

F_06: Factory setting refers to F_25.

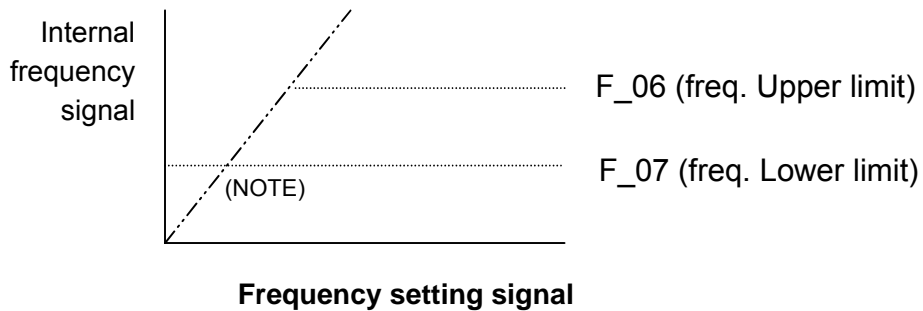

NOTE:

If F_07 = 0 Hz, The frequency instruction is equal to 0Hz, the inverter will stop at 0 speed.

If F_07 > 0 Hz, The frequency instruction F_07, the inverter will output a minimum speed according to the setting in F_07

F_08: SP1 frequency = 1 ~ 120Hz(1~200Hz:CPU version v1.9 and above)

F_09: JOG frequency = 1 ~ 120Hz(1~200Hz:CPU version v1.9 and above)

1. When F_19 or F_20 = 2 and the multifunction input terminal is ON, the inverter operates at sp1 frequency (F_08)
2. When F_19 or F_20 = 1 and the multifunction input terminal is ON, the inverter operate at jog frequency (F_09)
3. The priority of reading frequency setting is: Jog Sp1 Keypad setting or external frequency signal using a speed pot.

F_10: Start / Stop Control

= 0: Keypad

= 1: Terminal (TM2)

NOTE: When F_10=1 (Terminal Control), emergency stop on the Keypad is enabled.

When F_10=1, please refer to the descriptions of F_23/24, in order to avoid the damage to the human and the machine.

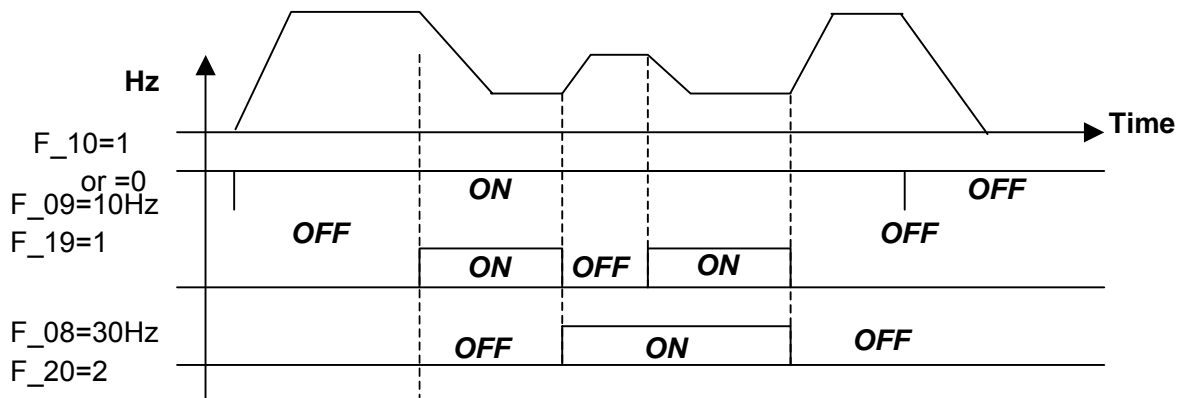

F_11: Speed Control**= 0: Keypad****= 1: Analog Speed Pot Terminal (TM2) (0 ~ 10V / 0-20mA)****= 2: Analog Speed Pot Terminal (TM2) (4-20mA)****NOTE 1:**

When jog frequency or Sp1 frequency is switched on, the frequency is setup by Sp1

speed, the buttons on the keypad is

disabled.

Original setting will be restored after the Sp1 connection is removed.

NOTE2:

During the contact closure of the jog function, the keypad control remains in a sleep state until the jog contact connection is re-opened.

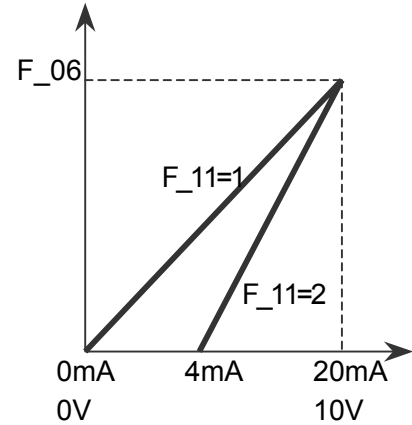
**F_12: Carrier Frequency = 1 ~ 10**

F_12	Carrier frequency	F_12	Carrier frequency	F_12	Carrier frequency
1	4 kHz	5	8 kHz	9	15 kHz*1
2	5 kHz	6	10 kHz*1	10	16 kHz*1
3	6 kHz	7	12 kHz*1		
4	7.2 kHz	8	14.4 kHz*1		

NOTE: *1: Available for CPU version V1.9 and above.

2: If F_12=7~10, the inverter must operator with low load.

Although an IGBT TYPE inverter can provide a low audible noise level during its operation, it is possible that the switching of the high carrier frequency may interfere with external electronic components (or other controllers) or even cause vibration in the motor. Adjusting the carrier frequency can usually correct this problem.

F_13: Torque compensation gain = 0 ~ 10 %

To enhance Inverter output torque patterns according to the B, C voltage points on the V/F pattern (refer to F_05 description) and the (F_13) for this feature.

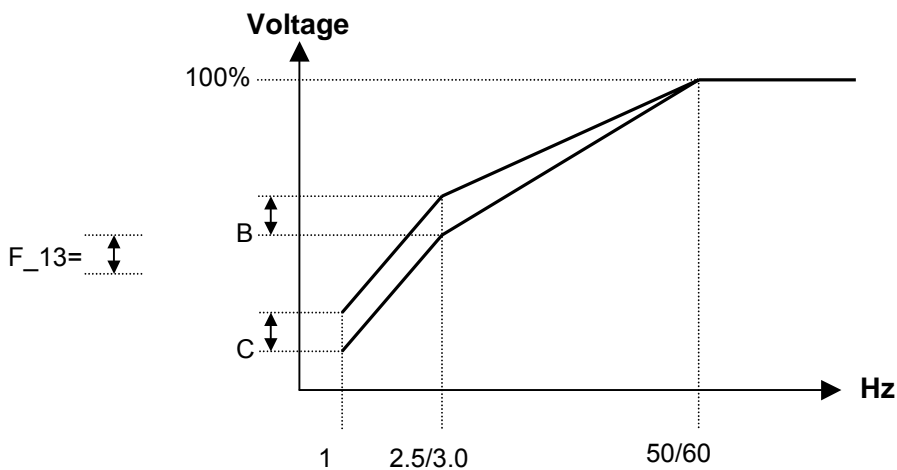

NOTE: When $F_{13} = 0$, the torque boost function is disabled.

F_14 Stopping method	= 0 : Controlled deceleration stop = 1 : free run to stop
F_15 DC braking time	= 0 ~ 25.5 sec
F_16 DC braking starting frequency	= 1 ~ 10 Hz
F_17 DC braking level	= 0 ~ 20 %

If $F_{14} = 0$

When the inverter receives the stop command, it decelerate to the pre-set frequency setup by F_{16} after this the output voltage level that is set in the F_{17} ; will determine the amount of DC voltage that's injected into the motor. The time duration to perform this stopping function is setup in F_{15} .

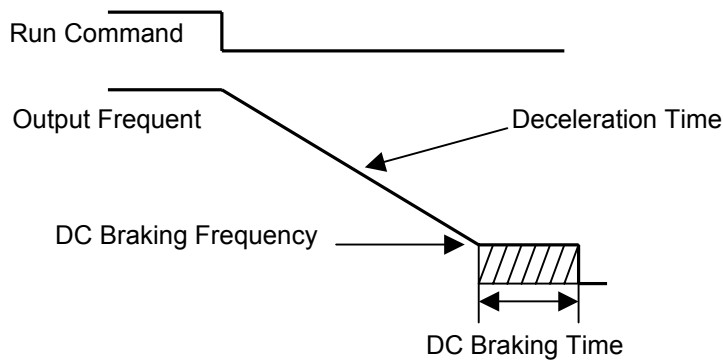

If $F_{14} = 1$

The inverter stops output immediately after receiving the stop command. The motor will enter into a free running state until it comes to a complete stop.

F_18: Motor rated current = 50~100 % (0~200%: CPU version v1.9 and above)

1. The electronic thermal overload protection for motor:

- (1) Motor rated current = Inverter rated current x F_18
 $F_{18} = \text{Motor rated current} / \text{inverter rated current}$
- (2) When the load is within 100% of the motors rated current, the operation continues. When the load reaches 150% of the motors rated current the operation is allowed to continue for 1 minute. (Refer to curve (1) in Figure 3)
- (3) After protecting the motor with the electronic thermal switch activated, the inverter is cut off immediately. The OLI light will flash. To resume operation, push the RESET button or activate an external reset connection wired to terminal 2.
- (4) When the motor is operating at low speeds, the heat dissipation efficiency is lower. The electronic thermal activation level is also reduced. (to change from curve (1) to curve (2) in Figure 3. Choose the appropriate F_05 setting according to the applied motor to reach the desired performance.

2. The electronic thermal protecting for inverter:

- (1) When the load is within 103% of the inverters rated current, the operation continues. When the load reaches 150% of rated current of the inverter, the operation will continue for 1 minute. (Refer to curve (1) of figure 3)
- (2) After the activation of the electronic thermal switch, the inverter is shut off immediately. The OL2 light will flash. To resume the operation, push RESET button or activate an external reset contact on terminal 2.

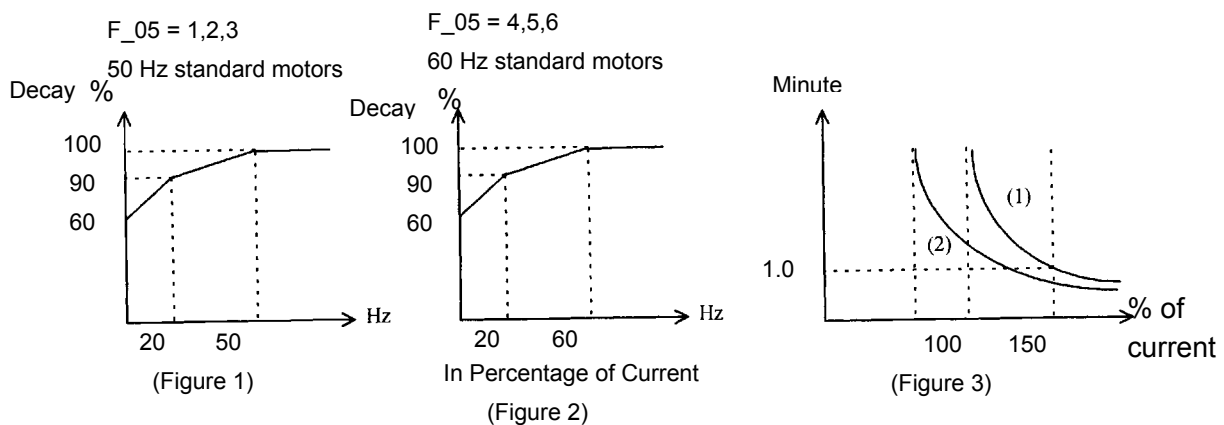

F_19: Multifunctional input terminal 1 function = 1~ 5(1~6:CPU version v1.9 and above)

F_20: Multifunctional input terminal 2 function = 1~ 5(1~6:CPU version v1.9 and above)

1. F_19=1 or F_20 =1: JOG control (refer to F_09)
2. F_19, F_20 =2 or 6 Multi-speed control:

F_19=2 & F_20=6:

TM2 SP1 Terminal	TM2 RESET Terminal	Output frequency
ON	OFF	F_08
OFF	ON	F_26
ON	ON	F_27

F_19=6 & F_20=2:

TM2 SP1 Terminal	TM2 RESET Terminal	Output frequency
ON	OFF	F_26
OFF	ON	F_08
ON	ON	F_27

NOTE: F_19,F_20=2 or 6 are new function for CPU version v1.9 and above.

3. **F_19, F_20 =3: External emergency stop**

When the external emergency stop signal is activated, the inverter proceeds to decelerate and stop, (ignoring the setting of F_14). The inverters E.S. light will flash after stopping. After the emergency stop signal is deactivated, turn the RUN switch OFF and then ON again to cycle it. (F_10 =1) Or, push the RUN key (F_10=0). The inverter will then resume operation and restart. If the emergency stop signal is removed before the inverter stops, the inverter will still execute the emergency stop.

4. **F_19, F_20 =4: External Base Block (Immediate Shut Down)**

When the external base block signal is activated, the inverter output will be immediately shut off (ignoring the setting of F_14) and flash b.b. Light. After the base block signal is deactivated, turn the RUN switch OFF and then ON again (F_10 = 1) or push the RUN key (F_10=0), the inverter will restart from the original starting frequency.

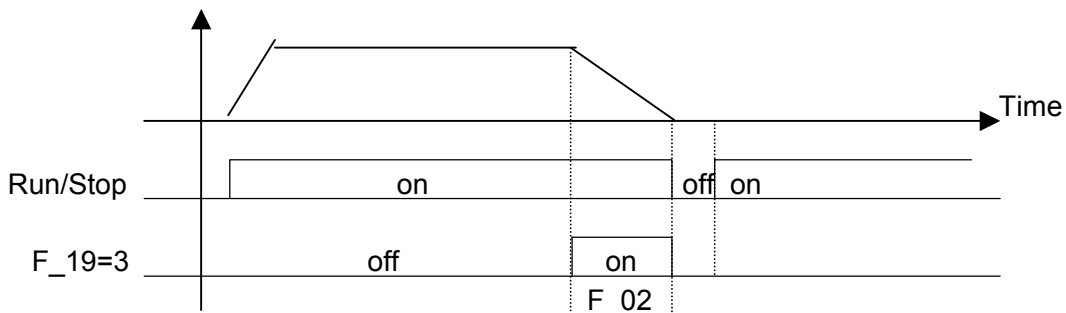

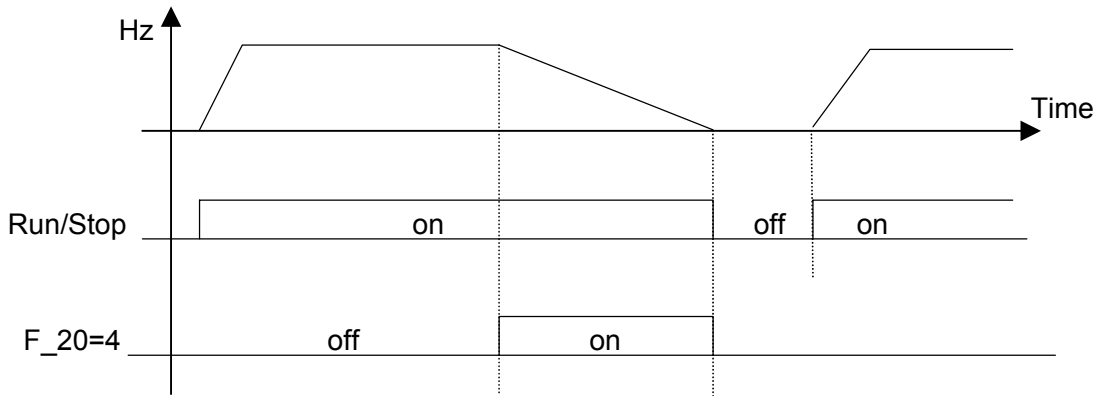

5. F_19, F_20 = 5: Auto Reset when inverter faults.

F_21: Multi-function output terminal control = 1 ~ 3

1. F_21 = 1: Run mode signal
2. F_22 = 2: At Frequency Speed Signal
3. F_21 = 3: Fault signal

Terminal1 and2 of TM2 are activated at CPF, OL1, OL2, OCS, OCA, OCC, Ocd , Ocb , OVC , LVC , OHC.

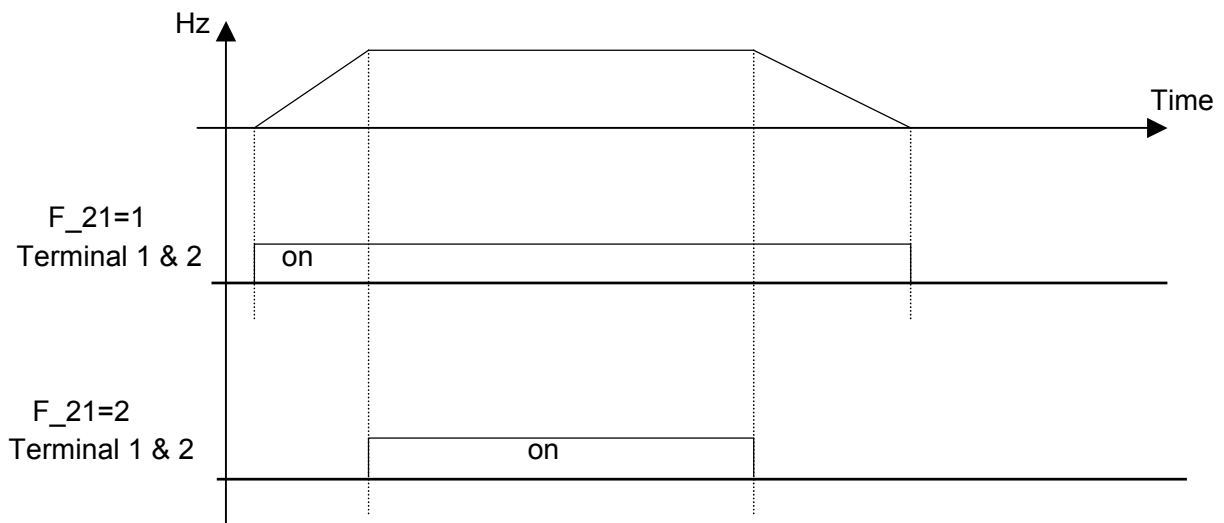

**F_22: Reverse Lock-Out = 0: REV command
= 1: REV command Lock-out**

NOTE:

When F_04 is set to 1 (reverse), F_22 cannot be set to 1, in order to properly lockout a motors direction, F_04 must be set at 0 before setting F_22 to 1.

F_23: Auto-restart after momentary power loss

=0: auto-restart enabled

=1: auto-restart disabled

1. When the AC power supply is temporary below low voltage protection levels because of power company issues or encountering large current loading in the same power supply system, the inverter will stop its output immediately. If the power source resumes within 2 seconds, the inverter can restart by using its speed search program.
2. When F_23=0:
 - (1) If the momentary power loss is less than 2 seconds, the inverter resume operation automatically via speed search at 0.5 seconds after power up. The number of auto-restart times is not limited by F_24.
 - (2) If the momentary power loss is long, the operation of the inverter is based on the setup of F_10 and the condition of external switch.
 - (3) If the time of momentary loss is between the above two, whether the inverter will auto-restart depends on F_24:
 - F_24=0: auto-restart disabled.
 - F_24=1~5: auto-restart enabled 1~5 times.
3. When F_23=1,
 - (1) Power up after momentary power loss, the inverter will not start. Even under F_24>0.
 - (2) If the momentary power loss is long, the inverter must be restart manually. The operation of the inverter is based on the setup of F_10 and the condition of external switch.
4. When restart the inverter, the operation of the inverter is based on the setup of F_10 and the condition of external switches (FWD/REV button).
 - (1) When F_10=0, the inverter will not start after restart.
 - (2) When F_10=1 and the external switch (FWD/REV button) is OFF, the inverter will not start after restart.
 - (3) When F_10=1 and the external switch (FWD/REV button) is ON, the inverter will start automatically after restart. Attention: Base on safety reason, please turn off the external switch (FWD/REV button) after power loss to avoid possible damage to the machine and the human body after sudden regeneration of power.

F_24: Number of Auto-restart times = 0~5

1. When F_24=0, the inverter will not auto-restart after a malfunction break away from operation. (Except for momentary power loss, please refer to F_23 for details)
2. When F_24=1~5: the inverter will resume operation via speed search at 0.5 second under auto-restart after malfunction break away. (Except for momentary power loss, please refer to F_23 for details).
3. When the inverter is set to deceleration or DC breaking, the transient restart procedure is not performed.

4. If either of following situations should develop, the auto restart times will be reset:
- (1) No additional malfunction (in operation or stop) occurs within 10 minutes.
 - (2) Press RESET button.

F_25: Return to Factory Pre-Settings

- = 010: Constants initialization to 50Hz system**
- = 020: Constants initialization to 60Hz system**

1. When F_25 is set to 010, all parameters are restored to factory settings. The settings of F_05 =1 and F_06 = 50. F_25 is restored back to 000 after the reset process is complete. (50Hz operation)
2. When F_25 is set to 020, all parameters are restored to factory settings. The settings of F_05 =4 and F_06 = 60. F_25 is restored back to 000 after the reset process is complete. (60Hz operation)

F_26: SP2(1~200Hz) , Multi-speed2 (Reference to F_19 & F_20)

F_27: SP3(1~200Hz) , Multi-speed3 (Reference to F_19 & F_20)

F_28: Direct start

- = 0 : Direct start enable when remote Run command on**
 - = 1 : Direct start disable when remote Run command on**
- (CPU version V2.1 and above)**

When F_28 = 1 and control mode is remote control (F_10 = 1), Inverter can not start if RUN switch is ON when power is engaged, Must be turned the RUN switch OFF and turned ON again, Then Inverter can start.

F_29: CPU program version

F_30: Last three faults

1. Last three faults: indicate the sequence of the occurrence of malfunctions by the location of decimal point. **x.xx** indicates a recently happened malfunction. **xx.x** indicates the last malfunction that happened. **xxx.** Indicates the earliest malfunction in the record.
2. After entering the F_30 function, the **x.xx** trip record will be displayed first. After that, press button and you can read activity in a chronological order. **xx.x** → **xxx.** → **x.xx** →,,, consecutively.
3. After entering F_30 function, if the RESET button is pressed, the trip record will be cleared. Indication display **-.--**, **--.-**, and **---.**
4. When the content of trip indicates O.CC, it will indicate the latest trip code is OC-C and so on.

Malfunction Indications and Countermeasures

1. Manual reset inoperative malfunctions

INDICATION	CONTENT	POSSIBLE CAUSE	COUNTERMEASURE
CPF	Program error	Outside noise interference	Place a RC surge absorber in parallel with the noise generating magnetic contact
EPR	EEPROM error	EEPROM defective	Replace EEPROM
OV	Voltage too high while not operating	1. Power source voltage too high. 2. Detection circuitry defective	1. Examine the power supply 2. Return the inverter for repair
LV	Voltage too low while not operating	1. Power source voltage too low. 2. Detection circuitry defective.	1. Examining the power supply 2. Return the inverter for repair
OH	Inverter over heat while not operating	1. Detection circuit defective. 2. Environment over-heat or poor ventilation	1. Return the inverter for repair 2. Improve ventilation

2. Manual reset operative malfunctions (Auto-Reset inoperative)

INDICATION	CONTENT	POSSIBLE CAUSE	COUNTERMEASURE
OC	Over-current at stop condition	Detection circuit malfunction	Return the inverter for repair
OL1	Motor over-load	1. Loading too large 2. Improper V/F model setting 3. Improper F_18 setting	1. Increase capacity of motor 2. Adjust to use a proper V/F curve setting 3. Adjust F_18 according to instruction
OL2	Inverter over-load	1. Loading too large 2. Improper V/F model setting	1. Increase capacity of inverter 2. Adjust to use a proper V/F curve setting

3.Manual Reset and Auto-Reset Operative Malfunction

INDICATION	CONTENT	POSSIBLE CAUSE	COUNTERMEASURE
OCS	Transient over-current starting machine	<ol style="list-style-type: none"> 1.Motor coil short-circuit with external casing 2.Motor connection wire short-circuit with grounding 3.Transistor module damaged 	<ol style="list-style-type: none"> 1.Examining motor 2.Examining wiring 3.Replace transistor module
OCA	Over-current at acceleration	<ol style="list-style-type: none"> 1.Acceleration time setting too short 2.Improper V/F feature selection 3.Applied motor capacity exceeds inverter capacity 	<ol style="list-style-type: none"> 1.Adjust acceleration time to longer setting 2.Adjust to a proper V/F curve 3.Replace and install another inverter with appropriate capacity
OCC	Over-current at steady speed	<ol style="list-style-type: none"> 1.Transient alteration of the loading 2.Transient alteration of the power supply 	<ol style="list-style-type: none"> 1.Examining the loading configuration 2.Install inductor on the power supply input side
OCD	Over-current at deceleration	Deceleration setting too short	Adjust to use a longer acceleration time
Ocb	Over-current at breaking	DC Breaking frequency, breaking voltage, or breaking time setting too long	Adjust to reduce settings of F_15, F_16, or F_17
OVC	Over-voltage at operation/deceleration	<ol style="list-style-type: none"> 1.Deceleration time setting too short or inertial loading too large 2.Power supply voltage variation too large 	<ol style="list-style-type: none"> 1.Adjust to use a longer deceleration time 2.Install a inductor on the power supply input side 3.Increase the capacity of inverter
LVC	Insufficient voltage level at operation	<ol style="list-style-type: none"> 1.Power supply voltage too low 2.Power supply voltage variation too large 	<ol style="list-style-type: none"> 1.Improve power source quality 2.Adjust to use a longer acceleration time 3.Increase capacity of inverter 4.Install a reactor on the power supply input side
OHC	Heat-sink over heated at operation	<ol style="list-style-type: none"> 1.Loading too heavy 2.Ambient temperature too high or poor ventilation 	<ol style="list-style-type: none"> 1.Examining the loading 2.Increase capacity of inverter 3.Improve ventilation

Special Condition Description

INDICATION	CONTENT	DESCRIPTION
SP0	Zero Speed Stopping	When F_11 = 0, F_7= 0 and frequency setting < 1 Hz When F_11 = 1, F_7<(F_6/100), and frequency setting <(F_6/100)
SP1	Fail to start directly	1. If the inverter is set to external operation (F_10 = 1) and direct start is disabled (F_28 =1), the inverter cannot be started and will flash SP1 when operation switch turned to ON after applying power (see descriptions of F_28). 2. Direct start is possible when F_28 = 0.
SP2	Keypad emergency stop	The inverter setup to external operation (F_10=1). If the STOP key in the keypad is pressed at the middle of operation, the inverter stops according the setting in F_14 and flash SP2 after stop. The RUN switch must be turned OFF than ON to restart the machine.
E.S.	External emergency stop	When the external emergency stop signal is activated through the multi-function input terminal, the inverter decelerates and stops. Inverter flashes E.S. after stops. (Refer to instruction for F_19 for detail).
b.b.	External BASE BLOCK	When the external BASE BLOCK signal is activated through the multifunction terminal, the inverter stop output immediately and flash b.b. for indication. (Refer to instruction for F_19 for detail)

Keypad Operation Error Instruction

INDICATION	CONTENT	POSSIBLE CAUSE	COUNTERMEASURE
LOC	Motor direction locked	1. Attempt to reverse direction when F_22 = 1 2. Attempt to set F_22 to 1 when F_04 = 1	1. Adjust F_22 to 0 2. Adjust F_04 to 0
Er1	Keypad operation error	1. Press or keys when F_11=1 or under sp1 operation 2. Attempt to modify F_29 3. Attempt to modify parameter that is not allowed to be modified during operation (refer to parameter list)	1. Use or keys to adjust frequency setting only after F_11=0 2. Do not modify F_29 3. Modify in stop mode
Er2	Parameter setting error	1. F_6 F_7	1. F_6 > F_7

General Malfunction Examination Method

ABNORMALITY	CHECK POINT	COUNTERMEASURE
Motor Inoperative	Is the power source voltage delivered to L1, L2 terminal (is the charging indicator illuminated)?	<ul style="list-style-type: none"> ● Check if the power source on. ● Turn power source OFF and then ON again. ● Reconfirm the power voltage level.
	Is there voltage output from output terminal T1, T2 and T3?	<ul style="list-style-type: none"> ● Turn power source OFF and then ON again.
	Is the motor wired correctly?	<ul style="list-style-type: none"> ● Check motor wiring.
	Is there any abnormal condition of the inverter?	<ul style="list-style-type: none"> ● Refer to malfunction handling instructions to examine and correct wiring.
	Is the forward or reverse instruction loaded?	
Motor Inoperative	Is the analog frequency setting loaded?	<ul style="list-style-type: none"> ● Check to see if wiring for analog frequency input signal is correct?
	Is the operation mode setting correct?	<ul style="list-style-type: none"> ● Check if the frequency input setting voltage is correct?
Motor operate in opposite direction	Is wiring on the output terminals T1, T2 and T3 correct?	<ul style="list-style-type: none"> ● Operate by digital?
	Is the wiring for the forward and reverse signals correct?	<ul style="list-style-type: none"> ● Wiring should be in accordance with the U, V, W terminals of motor.
Motor operation speed fixed	Is the wiring for analog frequency input correct?	<ul style="list-style-type: none"> ● Examining the wiring and correct it.
	Is the operation mode setting correct?	<ul style="list-style-type: none"> ● Examining the wiring and correct it.
	Is the loading too heavy?	<ul style="list-style-type: none"> ● Check the Operation panel
Motor operation at speed too high or too low	Is the specification of motor (poles, voltage) correct?	<ul style="list-style-type: none"> ● Reduce loading
	Is the gear ratio correct?	<ul style="list-style-type: none"> ● Reconfirm motor specification.
	Is the highest output frequency setting correct?	<ul style="list-style-type: none"> ● Reconfirm gear ratio
	Is the voltage on motor side reduced extremely?	<ul style="list-style-type: none"> ● Reconfirm highest output frequency
Abnormal speed variation at operation	Is the loading too heavy?	<ul style="list-style-type: none"> ● Reduce loading variation
	Is the loading variation too large?	<ul style="list-style-type: none"> ● Increase inverter and motor capacity
	Is the input power source steady and stable?	<ul style="list-style-type: none"> ● Install AC reactor on the power supply input side

Chapter 4: Troubleshooting Procedures

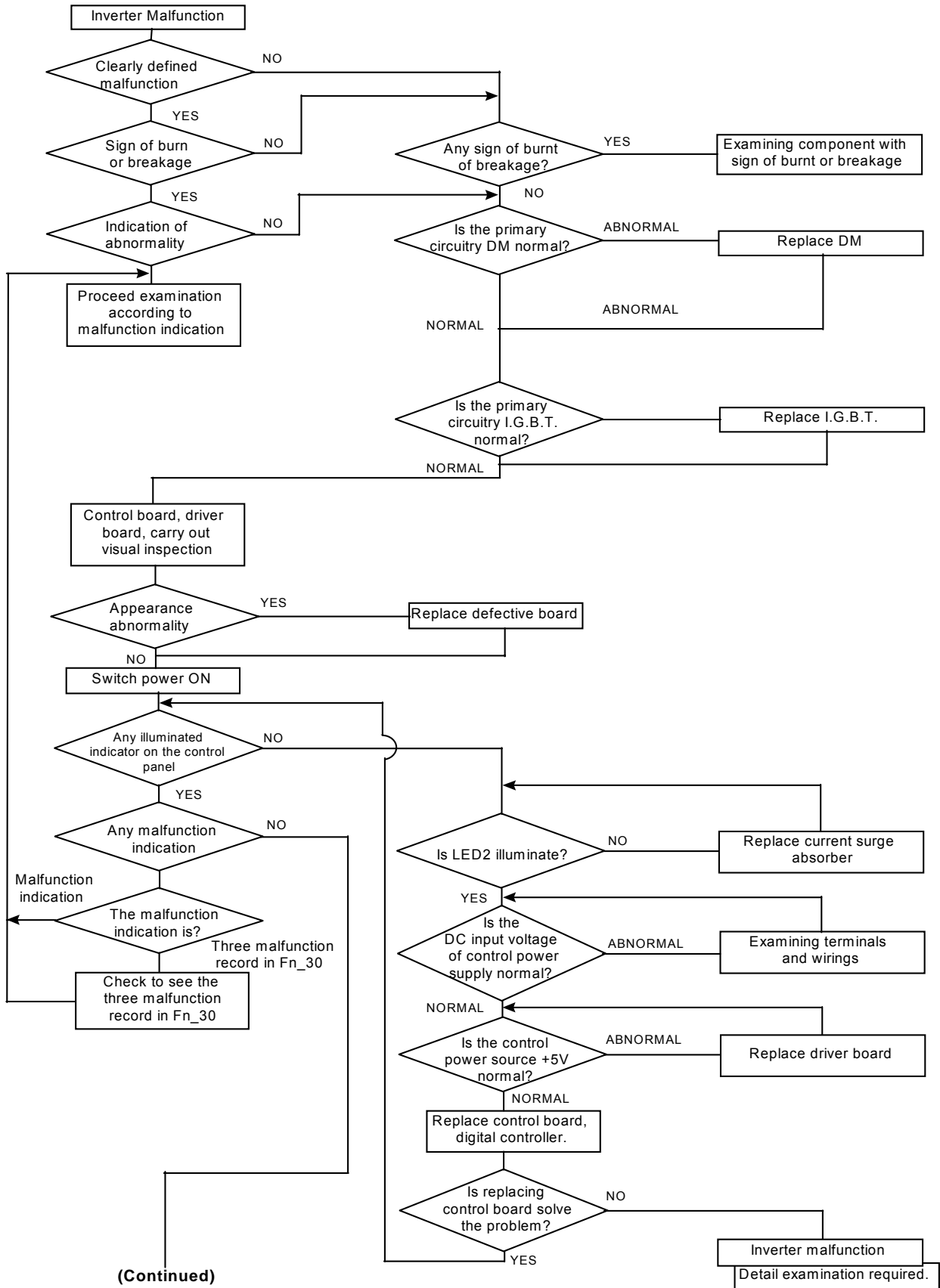

(Continued)

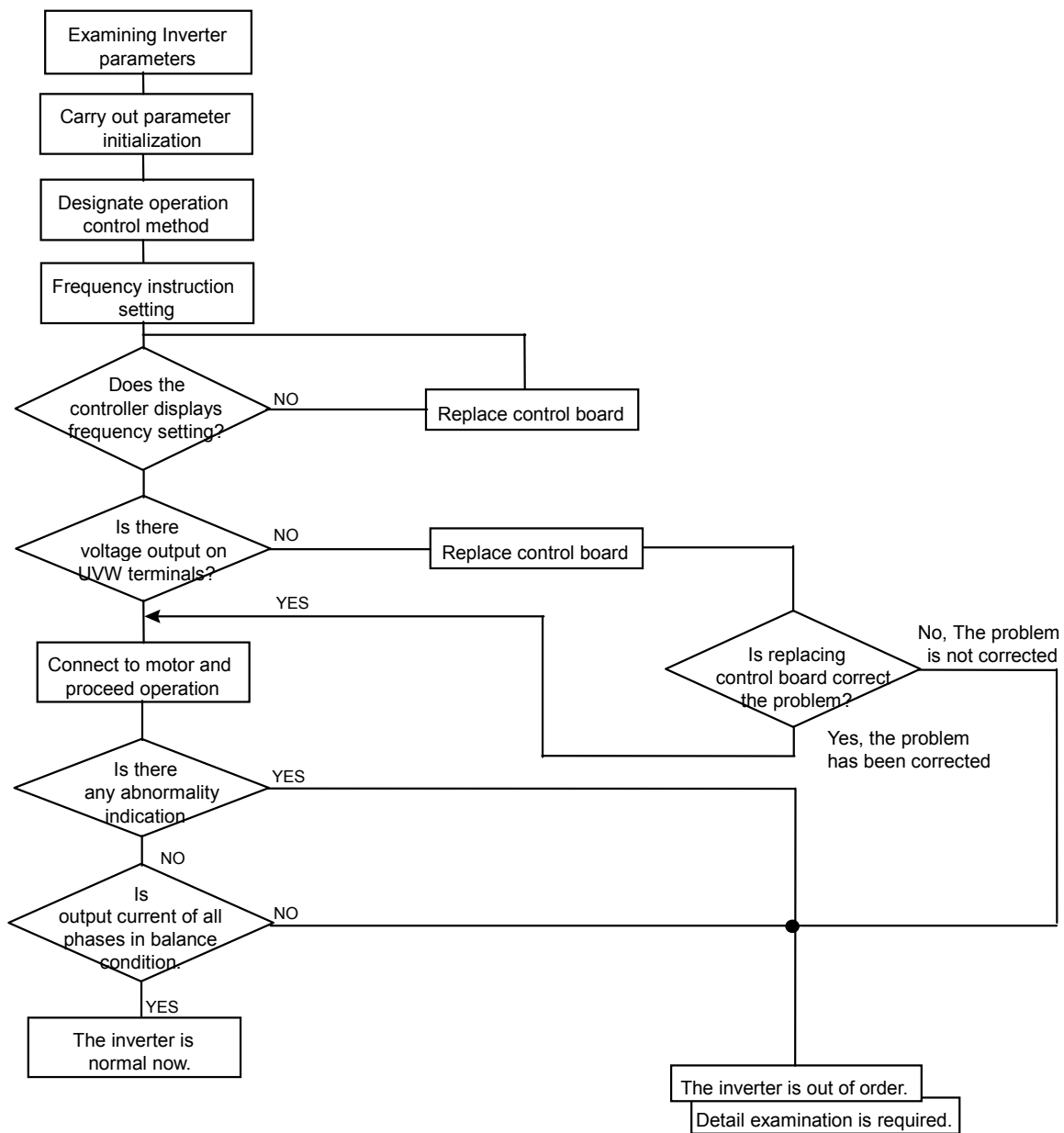

Error handling of malfunction indication of OC.OL

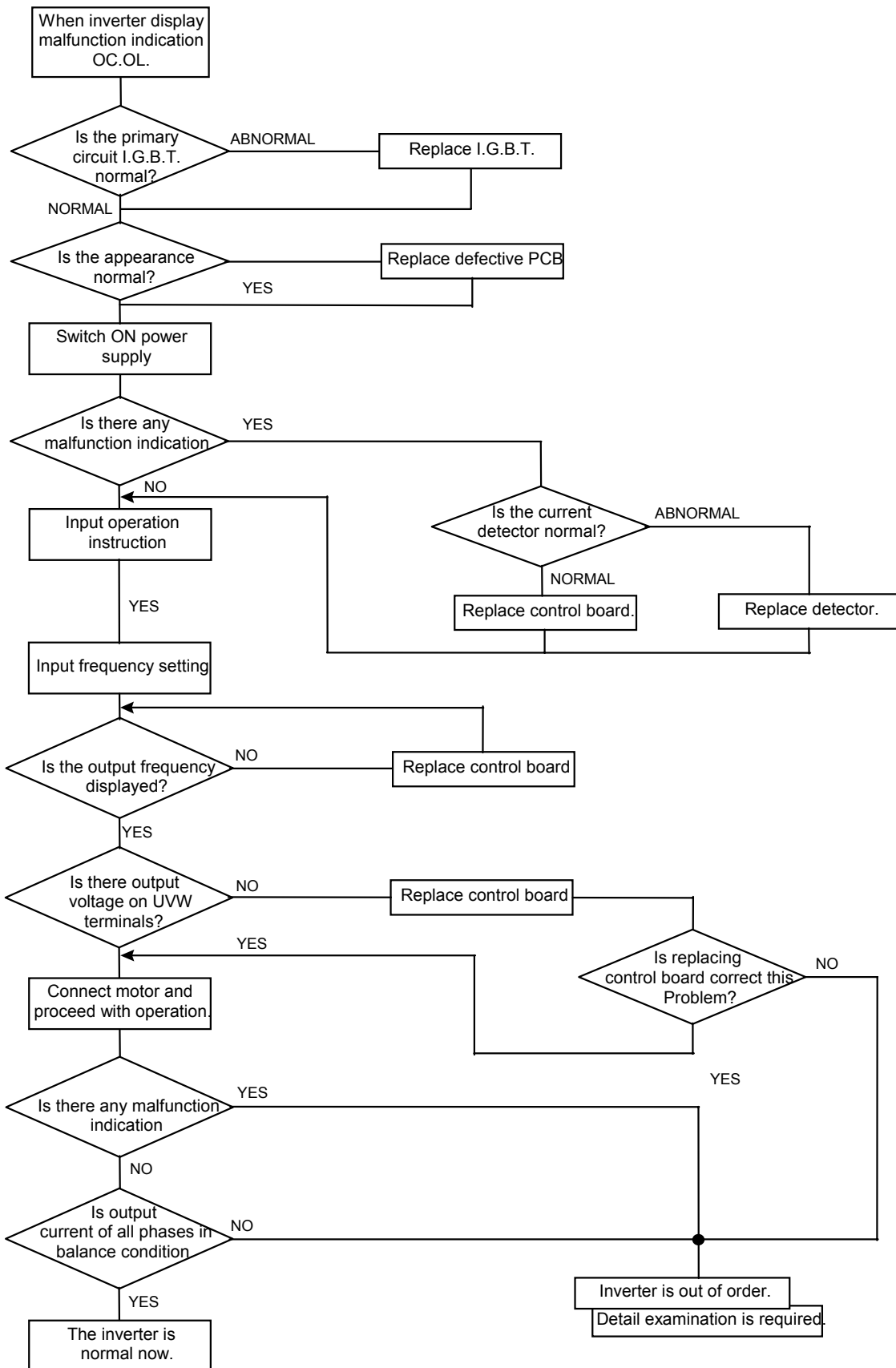

Error handling of malfunction indication of OV.LV

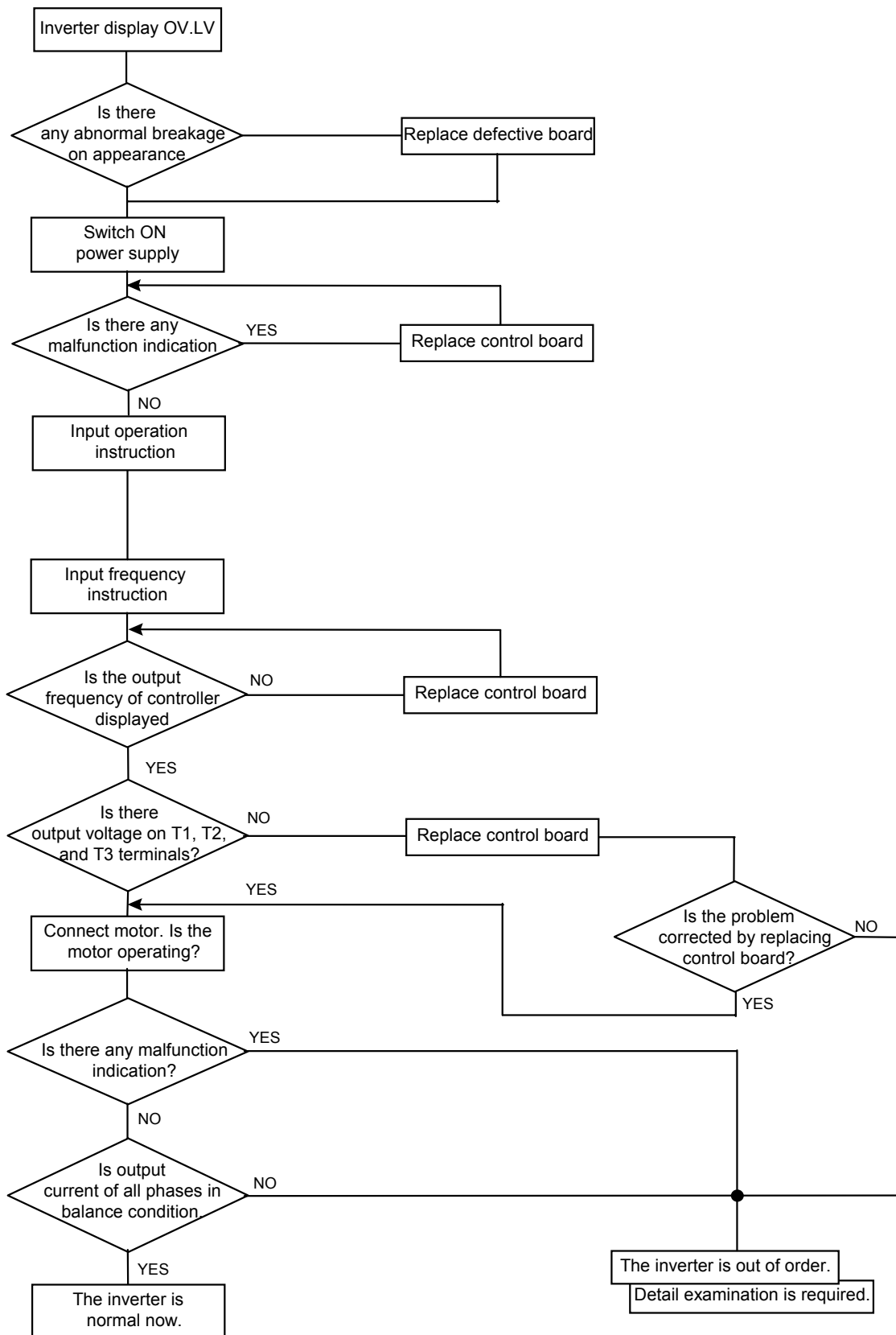

(1). Motor inoperative

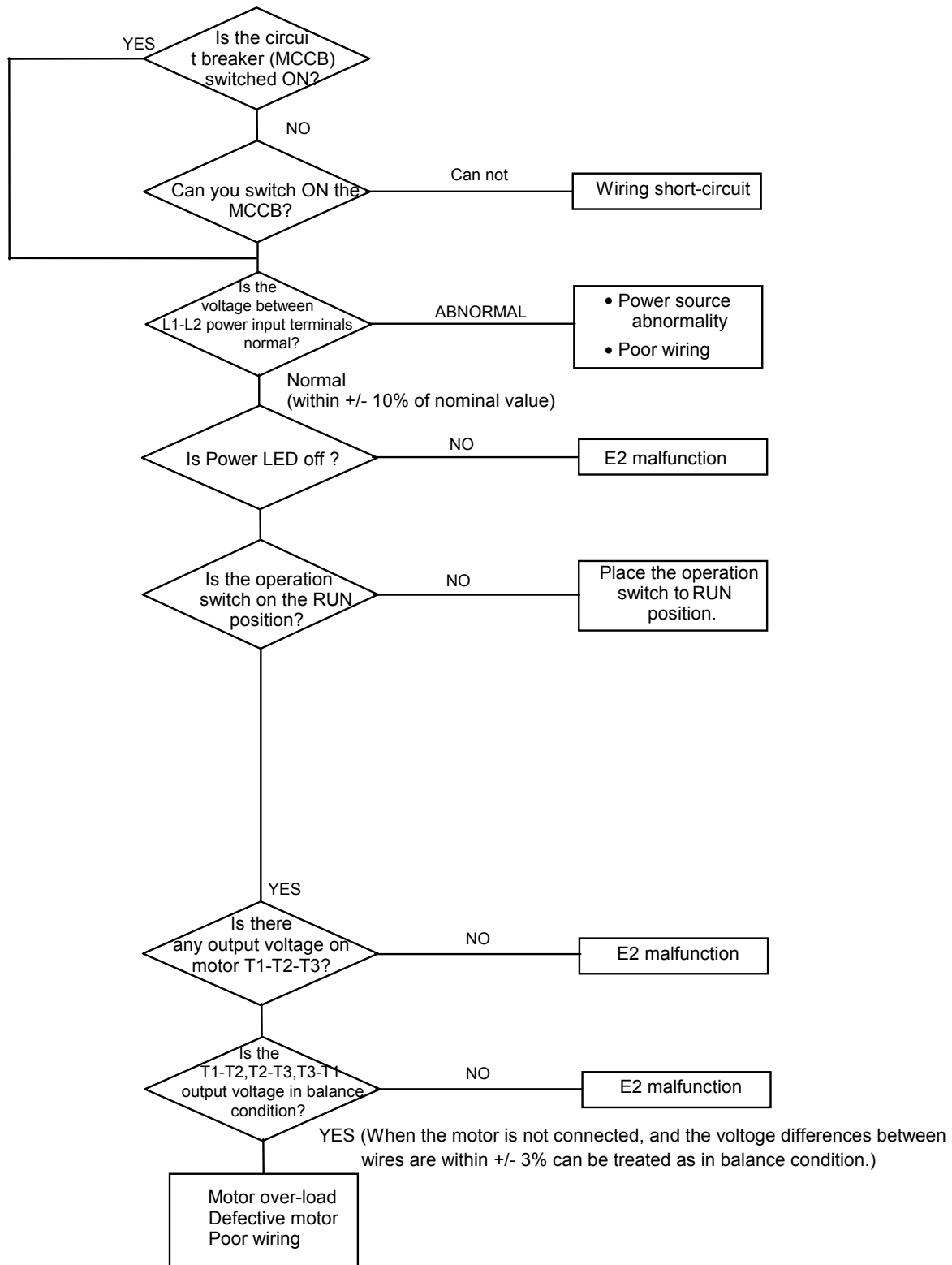

(2).Motor over-heat

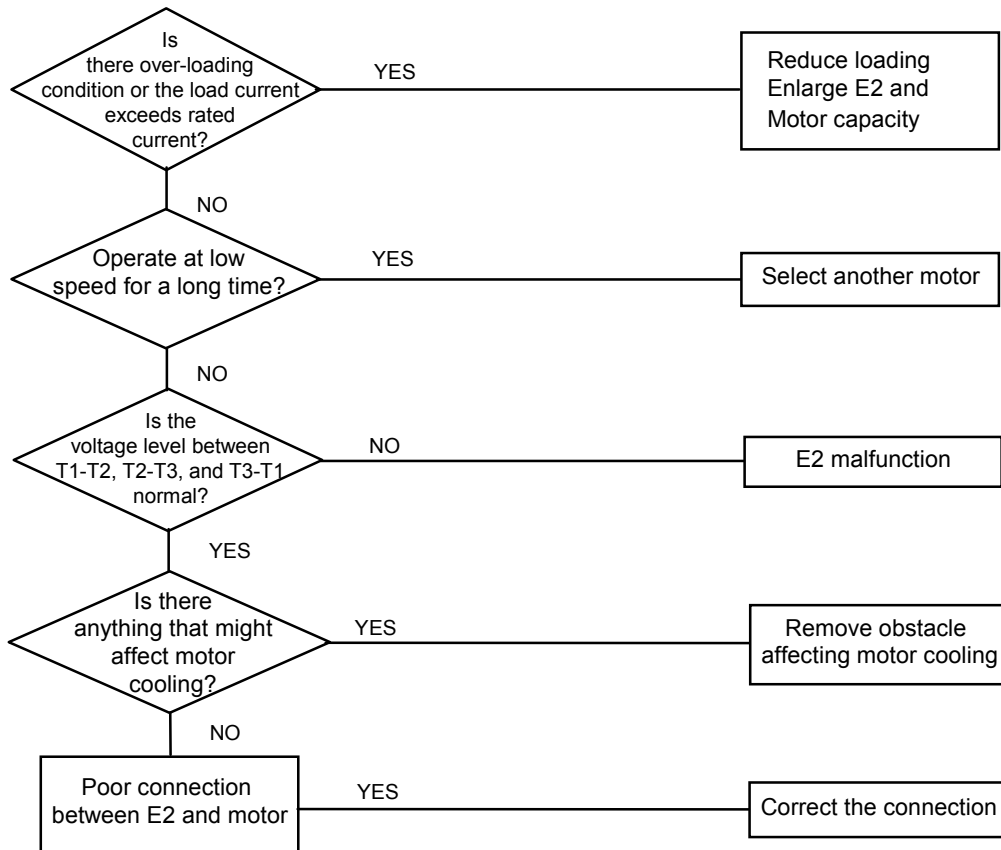

(3).Disturbing motor operation

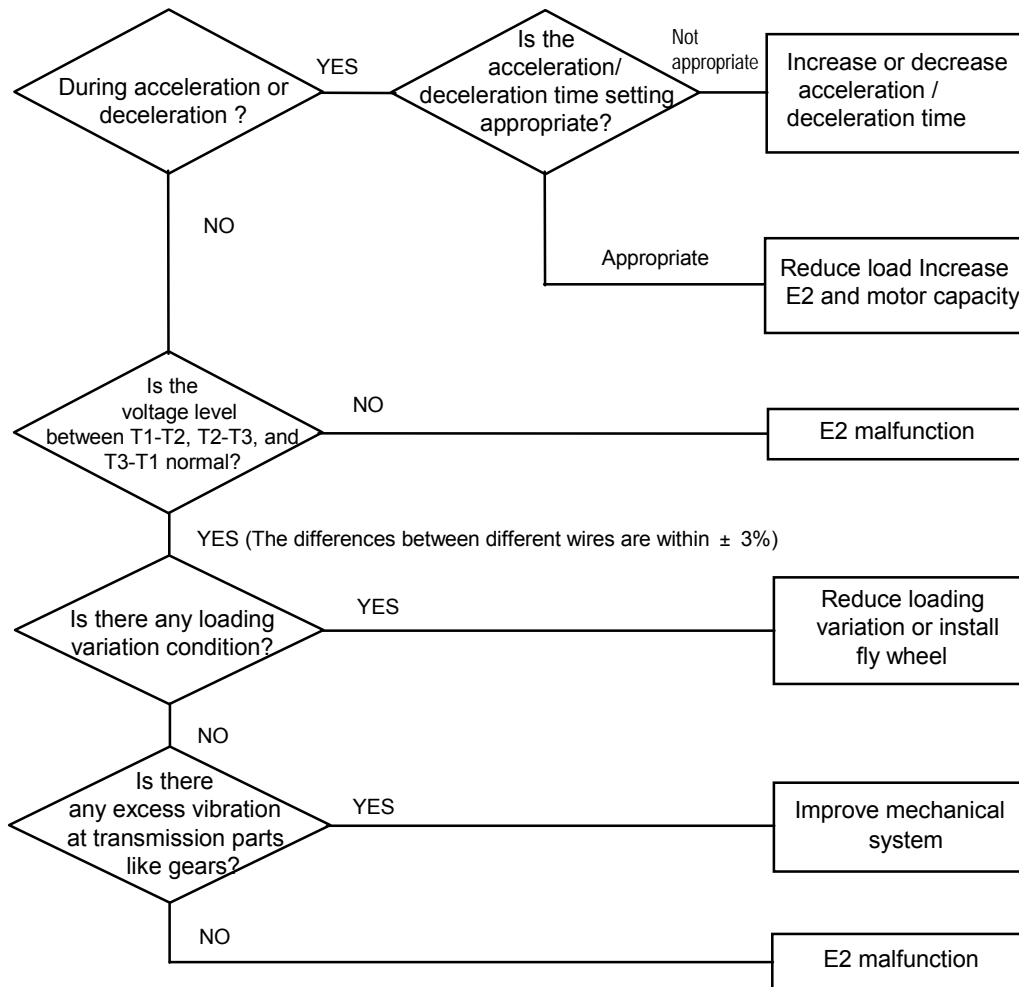

Routine examination and periodical examination

Inverter requires routine and periodical examination and maintenance

Carry out the examination only after the “ Power LED ” indicator goes off for at least 5 minutes

Maintenance item	Maintenance description	Examination period		Examination method	Criterion	Countermeasure
		Routine	1 Year			
Installation site environment	Reconfirm environment temperature and humidity			Refer to installation instructions and measure with thermometer and hygrometer	Temperature: -10~40 OC Humidity: under 95% without condensing	Improve installation site environment
	Check and remove any flammable material nearby			Visual inspection	No foreign object	
Inverter Installation and Grounding	Is there any abnormal vibration on the installation site?			Visual and audio Inspection	No foreign object	Tighten loose screw
	Is the grounding resistance within acceptable range?			Measure resistance by multi-meter	200V class under 100 ohm	Improve grounding
Input power source voltage	Is the voltage of the primary circuitry normal?			Measure voltage by multi-meter	Voltage level conforming specification	Improve input power source
Inverter external terminal mounting screw	Is the tighten parts secured?			Visual inspection. Use screwdriver to verify screw tightness	No abnormality	Tighten loose screw or return for repair
	Is there any sign of breakage on the terminal panel?					
	Is there any obvious rusty condition?					
Internal wiring of inverter	Is it deformed or skewed?			Visual inspection	No abnormality	Replace or return for repair
	Is the insulation of wire broken?					
Heat-sink	Is it accumulating dust or dirt?			Visual inspection	No abnormality	Clean up dust or dirt
PCB	Is it accumulating conductive metal or oil stain?			Visual inspection	No abnormality	Clean up or replace PCB
	Is there any over-heated or burnt component?					
Cooling fan	Is there any abnormal vibration or noise?			Visual and audio inspection	No abnormality	Replace cooling fan
	Is it accumulating dust or dirt?			Visual inspection		Clean up
Power component	Is it accumulating dust or dirt?			Visual inspection	No abnormality	Clean up
Capacitor	Is there any sign of strange order or leakage?			Visual inspection	No abnormality	Replace capacitor or inverter
	Is there any sign of swelling or bulging?					

Maintenance and Examination

Frequent examination and maintenance is not required for the inverter.

To maintain appropriate reliability, please proceed with following periodical examination. Remember to turn off power supply and wait till the Power LED goes off before proceed. (Due to the large amount of remaining charges in the internal capacitors.)

- (1) Clean out internal dust and dirt.
- (2) Check out mounting screws on every terminal and parts. Tighten loose screws.
- (3) Dielectric strength test
 - (a) Remove all conducting wires between Drive and outside world. Power must be turned OFF.
 - (b) The dielectric strength test inside Drive should be carried out only for T-VERTER major circuitry. Use DC 500V: high resistance meter. Measured resistance should be higher than 100M ohm.

CAUTION: Do not perform dielectric strength test to the control circuit.

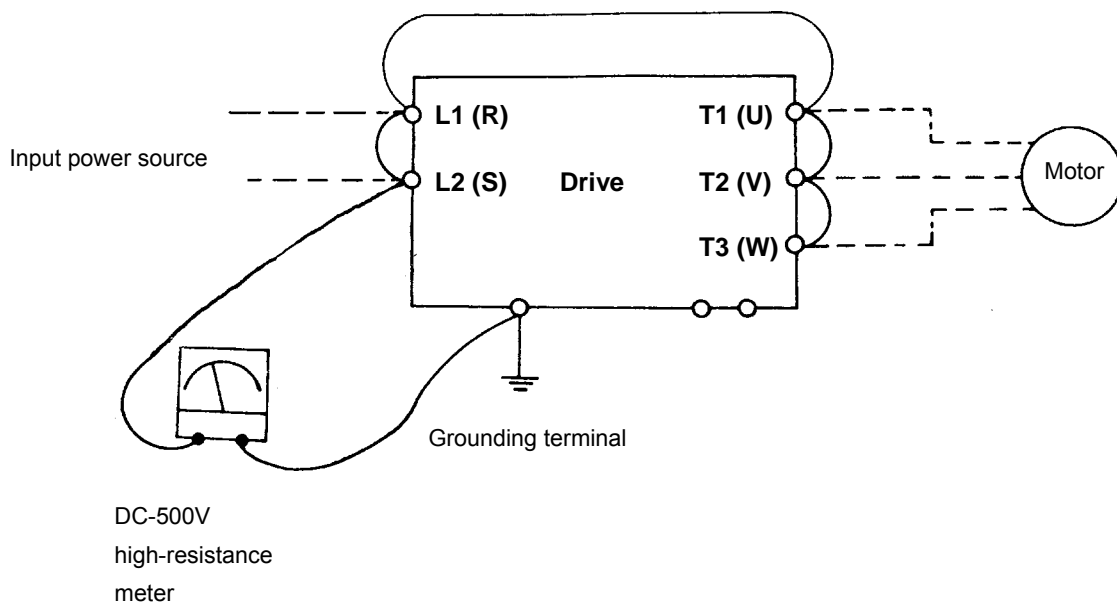

Connection for dielectric strength test

Voltage Current Measurement

The voltage and current measurement on the primary and secondary side of the inverter may be different due to instrumentation variations. Refer to following diagram for measurement:

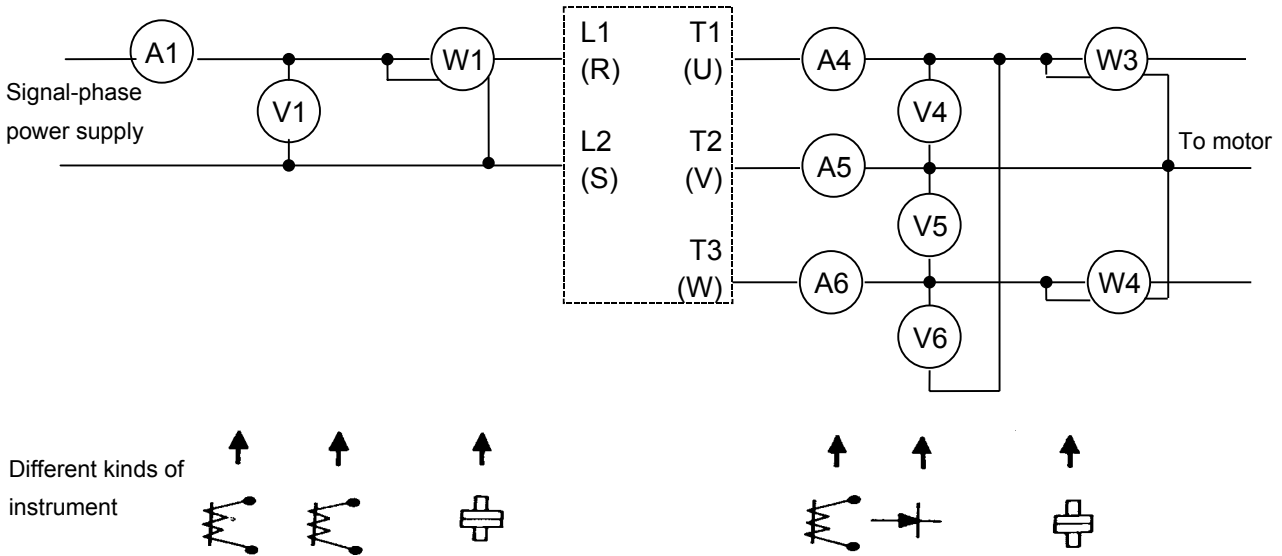

Measurement	Measuring point	Instrument	NOTE (Measurement criterion)
Input voltage V_i	(V1)	Moving-iron	
Input current I_i	(A1)	Moving-iron	
Input power P_i	(W1)	Power-meter	$P=W1$
Input power factor PF_i	Calculate power factor by the input voltage, input current and input power $PF_i = \frac{P_i}{\sqrt{3}V_i \cdot I_i} \times 100\%$		
Output voltage V_o	(V4) (V5) (V6)	Rectifier (Moving-iron not allowed)	Maximum voltage difference between wires under 3%
Output Current I_o	(A4) (A5) (A6)	Moving-iron	Under the inverter rated current
Output power P_o	(W3) (W4)	Power-meter	$P_o=W3+W4$
Output power factor	$PF_o = \frac{P_o}{\sqrt{3}V_o \cdot I_o} \times 100\%$		

EMI Filter (class B) Specification

Model	Dimension (mm)	Current (A)	Inverter model
E2F-2102	156 X 76 X 25	10A	E2-2P2-M1F/E2-2P2-H1F E2-2P5-M1F/E2-2P5-H1F E2-201-M1F/E2-201-H1F
E2F-2202	172 X 120.2 X 11	20A	E2-202-H1F E2-203-H1F
E2F-4103	172 X 120.2 X 11	10A	E2-401-H3F E2-402-H3F E2-403-H3F

DIN RAIL Specification

Model	Dimension (mm)	Inverter model
DIN E2-201	130 x 72 x 7.5	E2-1P2/1P5/101/2P2/2P5/201 E2-202/203/401/402/403

Specification of Braking Resister and Input Reactor

MODEL	Braking transistor build-in	Braking resister build-in	Torque of braking	Model of braking resister	Input AC Reactor	
					Current (A)	Inductance (mH)
E2-2P2-x1xx	X	X	20%	Note 1	3	7.0
E2-2P5-x1xx	X	X	20%	Note 1	5.2	4.2
E2-201-x1xx	X	X	20%	Note 1	9.4	2.1
E2-202-Hxx		X	20%	BRN2-202	19	1.1
E2-203-Hxx		X	20%	BRN2-203	25	0.71
E2-401-H3xx		X	20%	BRN2-401	2.5	8.4
E2-402-H3xx		X	20%	BRN2-402	5.0	4.2
E2-403-H3xx		X	20%	BRN2-403	7.5	3.6

: Built-in X: Without built-in

Note 1: Without transistor and resister built-in.

Specification of Braking Resister

Model of Inverter	Model of Braking resister	Rate of Motor (KW)	Specification of Braking Resister		Braking Resister ED(%)	Torque of braking (%)	Size of resister (L*W*H) mm	Size of carton (L*W*H) mm	Weight (5pc) N.W (kg)
			(W)	()					
E2-202-Hxxx	BRN2-202	1.5	150	100	10	119	215*40*20	325*225*70.5	2.1
E2-203-Hxxx	BRN2-203	2.2	200	70	9	116	165*60*30	200*195*80	3.2
E2-401-H3xx	BRN2-401	0.75	60	750	8	125	115*40*20	200*195*80	1.1
E2-402-H3xx	BRN2-401	1.5	150	400	10	119	215*40*20	325*225*70.5	2.1
E2-403-H3xx	BRN2-403	2.2	200	250	8	128	165*60*30	200*195*80	3.2

Note: 1. Braking level: 385/770Vdc for E2-200/400 series

2. Braking resister mounting is below:

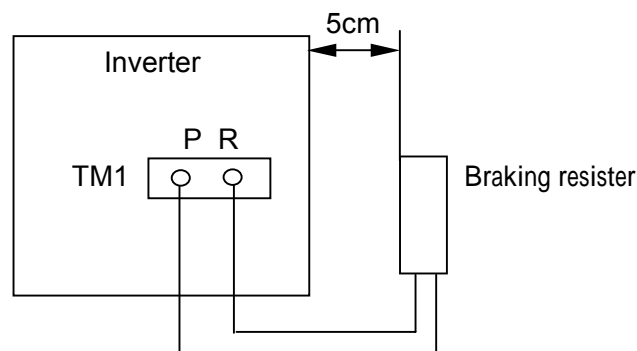

PARAMETERS TABLE

CUSTOMER				MODEL	
APPLICATION				TELEPHONE	
ADDRESS					
F_##	Value Setting	F_##	Value Setting	F_##	Value Setting
F_00		F_11		F_22	
F_01		F_12		F_23	
F_02		F_13		F_24	
F_03		F_14		F_25	
F_04		F_15		F_26	
F_05		F_16		F_27	
F_06		F_17		F_28	
F_07		F_18		F_29	
F_08		F_19		F_30	
F_09		F_20			
F_10		F_21			

Distributor



8F. 156-2. Sung Chiang Road

Taipei, Taiwan, Republic of China

Tel:886-2-25111181 Fax:886-2-25633586

<http://taian-electric.com.tw>

This manual may be modified when necessary because of improvement of product, modification or change in specifications. This information is subject to change without notice

B3481-7 Ver:07 2003.02