



VECTRON

Profibus-DP communication module CM-PDP

08/03

GB



Frequency Inverter 230 V / 400 V
ACT200 / ACT400

Installation /	:
Machine designation	:
Frequency inverter type	:
Serial-No.	:

051-601-083

General points on the documentation

The present supplement of the documentation is valid for the frequency inverter of the device series ACT200 and ACT400. The information necessary for the assembly and application of the Profibus-DP communication module CM-PDP is documented in this guidance.

For better clarity, the user documentation is structured according to the customer-specific demands made of the frequency inverter.

Brief instructions

The brief instructions describe the fundamental steps for mechanical and electrical installation of the frequency inverter. The guided commissioning supports you in the selection of necessary parameters and the software configuration of the frequency inverter.

Operating instructions

The operating instructions document the complete functionality of the frequency inverter. The parameters necessary for specific applications for adaptation to the application and the extensive additional functions are described in detail.

Application manual

The application manual supplements the documentation for purposeful installation and commissioning of the frequency inverter. Information on various subjects connected with the use of the frequency inverter are described specific to the application.

The documentation and additional information can be requested via your local representation of the firm of VECTRON Elektronik. The following pictograms and signal words are used for the purposes of the present documentation:



Danger

means a directly threatening danger. Death, serious damage to persons and considerable damage to property will occur if the precautionary measure is not taken.



Warning

marks a possible threat. Death, serious damage to persons and considerable damage to property can be the consequence if attention is not paid to the text.



Caution

refers to an indirect threat. Damage to people or property can be the result.

Attention

refers to a possible operational behavior or an undesired condition that can occur in accordance with the reference text.

Note

marks information that facilitates handling for you and supplements the corresponding part of the documentation.



Warning: In installation and commissioning, comply with the information in the documentation. You as a qualified person must read the documentation carefully before the start of the activity and obey the safety instructions. For the purposes of the instructions, "qualified person" designates a person acquainted with the erection, assembly, commissioning and operation of the frequency inverters and possessing the qualification corresponding to the activity.

Table of Content

1	General safety and application information	4
1.1	General information	4
1.2	Proper use	4
1.3	Transport and storage	5
1.4	Handling and positioning	5
1.5	Electrical connection	5
1.6	Operation information	5
1.7	Maintenance and upkeep	5
2	Introduction	6
3	Assembly of the Profibus-DP communication module CM-PDP	7
4	Socket occupancy/bus termination/line	8
5	Baud rate setting/line length	9
6	Setting station address	9
7	Setting PPO type	9
7.1	Configuration process on the DP master	10
8	Commands SYNC / FREEZE	11
9	Available objects / scanning times	11
10	Handling of the objects	13
10.1	Communication channel	13
10.1.1	Order identification	14
10.1.2	Reply identification	14
10.1.3	Fault messages	14
10.1.4	Parameters, data set selection and cyclic writing	15
10.1.5	Sequence of communication	16
10.1.6	Examples of communication	17
10.2	Process data channel PZD1/PZD2	19
10.2.1	PZD1, control word / state word	19
10.2.2	Control via contacts	20
10.2.3	Control via state machine	21
10.2.3.1	Behavior in quick stop	24
10.2.3.2	Behavior in transition 5	24
10.2.4	Control via remote contacts	25
10.2.5	PZD2, reference value / actual value	27
10.2.6	Variable actual value reporting via PZD2 in PPO1 / PPO3	28
10.2.7	Actual value report PZD2 to PZD6 in PPO2 / PPO4	29
10.2.8	PPO-Out data as global sources	30
10.3	Actual value display of Profibus data	35

Table of Content

11	Parameter list.....	37
11.1	Actual value	37
11.2	Parameter	37
12	Annex.....	38
12.1	Warning messages.....	38
12.2	Fault messages.....	38
12.3	GSD File – VEC_0696.GSD	39

1 General safety and application information

This documentation has been produced with the greatest of care and extensively and repeatedly checked. For reasons of clarity, not all the detailed information on all types of the product and also not every imaginable case of erection, operation or maintenance have been taken into account. If you require further information or if specific problems which are not dealt with extensively enough in the documentation exist, you can request the necessary information via the local representation of the firm of VECTRON Elektronik.

We would also point out that the contents of this documentation are not part of a previous or existing agreement, assurance or legal relationship and are not intended to amend the same. All obligations of the manufacturer result from the underlying purchase contract, which also contains the complete and solely valid warranty regulation. These contractual warranty provisions are neither extended nor limited by the production of this documentation.

The manufacturer reserves the right to correct or amend the contents and the product information as well as omissions without prior notification and assumes no kind of liability for damage, injuries or expenditure to be put down to the aforementioned reasons.

1.1 General information

Depending on their protection class, VECTRON frequency inverters can have live, also moving parts as well as hot surfaces during operation.

In the event of inadmissible removal of the necessary covers, improper use, wrong installation or operation, there is the risk of serious damage to persons or property.

In order to avoid serious physical damage or considerable damage to property, only qualified trained personnel may carry out the work for transport, installation, commissioning and maintenance. The norms EN 50178, IEC 60364 (Cenelec HD 384 or DIN VDE 0100), IEC 60664-1 (Cenelec HD 625 or VDE 0110-1), BGV A2 (VBG 4) and national provisions are to be complied with. Qualified persons within the meaning of this principal safety information are people acquainted with the erection, fitting, commissioning and operating of frequency inverters or in possession of qualifications matching their activities.

1.2 Proper use

The frequency inverters are electrical drive components intended for installation in industrial plant or machines. Commissioning and start of intended operation are not allowed until it has been established that the machine corresponds to the provisions of the EC machine directive 98/37/EEC and EN 60204. According to the CE sign, the frequency inverters additionally fulfill the requirements of the low-voltage directive 73/23/EEC and the norms EN 50178 / DIN VDE 0160 and EN 61800-2. Responsibility for compliance with the EMC directive 89/336/EEC is with the user. Frequency inverters are available in a limited way and as components exclusively intended for professional use within the meaning of the norm EN 61000-3-2.

With the issue of the UL test sign according to UL508c, the requirements of the CSA Standard C22.2-No. 14-95 have also been fulfilled.

The technical data and the information on connection and ambient conditions can be seen from the rating plate and the documentation and are to be complied with at all costs.

1.3 Transport and storage

Transport and storage are to be done in an adequate way in the original packaging. Storage shall be in dry rooms protected against dust and moisture with slight temperature fluctuations. Please observe the climatic conditions according to EN 50178 and the marking on the packaging.

The duration of storage without connection to the admissible reference voltage may not exceed one year.

1.4 Handling and positioning

The frequency inverters are to be used according to the documentation, the directives and the norms. Ensure careful handling and avoid mechanical overloading. In transport and handling, do not bend the construction elements or alter the insulation distances. Do not touch any electronic construction elements and contacts. The devices contain construction elements with a risk of electrostatic which can easily be damaged by improper handling. Damaged or destroyed components may not be put into operation as they can be a risk to your health and compliance with the applied norms is not guaranteed.

1.5 Electrical connection

In work on the frequency inverters, please observe the applicable norms BGV A2 (VBG 4), VDE 0100 and other national directives. The information in the documentation on electrical installation and the relevant directives are to be observed. Responsibility for compliance with and examination of the limit values of the EMC product norm EN 61800-3 for variable-speed electrical drive mechanisms is with the manufacturer of the industrial plant or machine.

The documentation contains information on installation correct for EMC. The wires connected to the frequency inverters may not be subjected to an insulation test with a high-test voltage without prior wiring measures.

1.6 Operation information

Before commissioning and the start of the intended operation, all the covers are to be attached and the terminals checked. Check additional monitoring and protective devices pursuant to EN 60204 and the safety directives applicable in each case (e.g. Working Machines Act, Accident Prevention Directives etc.). Before working on the frequency inverter, the latter must be switched off, and you are not allowed to touch live connections immediately as the capacitors can be charged up. Please observe the information and markings on the frequency inverter.

1.7 Maintenance and upkeep

Unauthorized opening and improper interventions can lead to physical injury or damage to property. Repairs on the frequency inverters may only be done by the manufacturer or persons authorized by the latter.

2 Introduction

This document describes the features of the Profibus-DP communication module CM-PDP for the frequency inverter of the series ACT.

For the Profibus-DP connection, the frequency inverter must be equipped with the Profibus-DP communication module CM-PDP. The Profibus component CM-PDP is enclosed with the inverter as a separate part and must be fitted by the user. This is extensively described in the chapter "Assembly".

Note: These instructions are not to be understood as fundamental information on the Profibus-DP. They presuppose underlying knowledge of the methods and modes of effect of the Profibus-DP on the part of the user. In some points, setting and display possibilities are described alternatively to the control unit KP500 via the VPlus PC program. The operation of a PC with the VPlus program on the frequency inverter with use of the Profibus component CM-PDP is only possible via an optional interface adapter KP232 on the slot of the keypad.

The Profibus component CM-PDP has the **ident number 0x0696** (hexadecimal). The device's data set file has the designation **VEC_0696.GSD** and is attached to the appendix of this documentation. Identification number and designation of the GSD file have been assigned by the Profibus user organization in Karlsruhe.

Attention: With the help of the Profibus-DP communication module CM-PDP it is possible to access **ALL** parameters of the frequency inverter from the external control. The control of the access by control levels with the control unit KP500 or the PC software VPlus does not exist. A change of parameters, whose meaning does not admit to the user can lead to the inoperability of the frequency inverter.

3 Assembly of the Profibus-DP communication module CM-PDP

The Profibus component CM-PDP is delivered pre-fitted for assembly in a housing. In addition, a PE spring is enclosed for the PE connection (screening) of the communication module.



Caution: Before the assembly of the Profibus component CM-PDP, the inverter must be switched free of voltage. Assembly under voltage is not admissible and leads to a destruction of the frequency inverter and / or the Profibus component.

In the first step, the covers are to be removed. After this, the plug-in section for the Profibus-DP communication module CM-PDP is accessible.

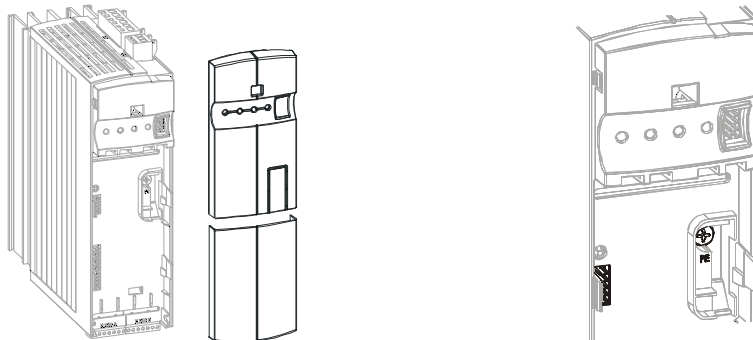

To start with, the supplied PE spring is fitted with the help of the M4 screw in the device. The spring must be aligned centrally. The Profibus component CM-PDP can now be fitted and screwed onto the PE spring with the M2 screw available on the module.

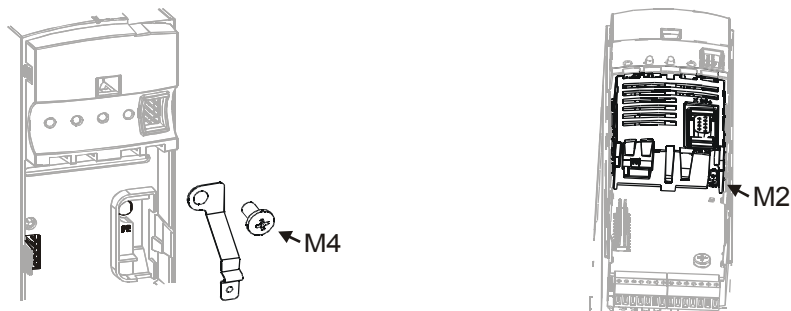

Caution: The Profibus-DP communication module CM-PDP is pre-fitted in a housing. The PCB visible on the back may not be touched, as modules can be damaged by this.

After this, the covers have to be fitted again. In the upper cover, the pre-stamped breakthrough for plug X310 is to be broken out and the cover fitted again.

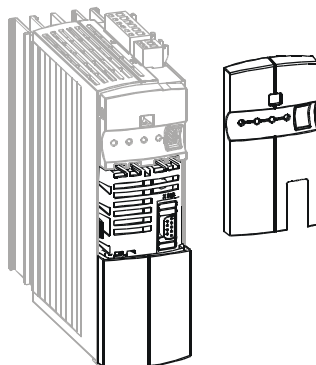

4 Socket occupancy/bus termination/line

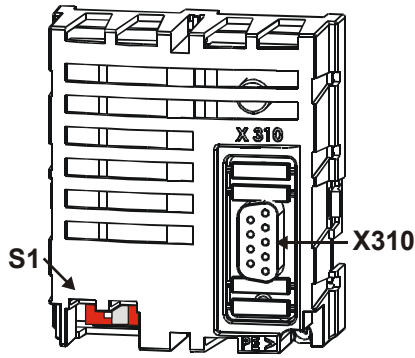

The bus socket **X310** (9-pole Sub-D) is occupied according to the Profibus DP norm EN50170.

Please take the details for the pin allocation of the bus plug from the following table.

The bus termination necessary on the bus line in the physically first and last subscriber can be activated via the **DIP switch S1** on the Profibus module.

The factory setting for the bus termination is OFF.

As an alternative, this is possible via corresponding circuits in the bus connection sockets (e.g. made by Siemens).

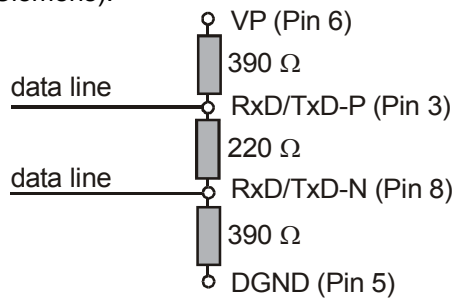

Attention: It is absolutely necessary that only one of the two possibilities for the bus termination is used and the bus termination is only switched on with the first and last subscriber. If not, operation of the Profibus is not possible.

If the bus termination is activated on an inverter (Profibus component or bus socket), it is only correctly effective if the inverter has contact to voltage. If not, the bus is not operation-capable.

Bus plug X310		
Pin	Name	Function
housing	screen	connected with PE
1	PE	PE
2	not used	-
3	RxD/TxD-P	positive signal RxD/TxD-P, corresponding to RS485 B-Line
4	CNTR-P	control signal for repeater
5	DGND	isolated ground for bus connection
6	VP	isolated 5V for bus connection
7	not used	-
8	RxD/TxD-N	negative signal RxD/TxD-N, corresponding to RS485 A-Line
9	not used	-

Only admissible types are to be used for the bus socket. They must all be suited for the 12 MBaud transmission rate.

This is, for example, type **Profibus connector 12 MBAUD** (6ES7 972-0BA11-0XA0) from Siemens.

Only admissible types are to be used as a line for the Profibus (line type A).

This is, for example, type **UNITRONIC-BUS L2/F.I.P. 1x2x0,64** from Lappkabel.

Attention: The line screen is to be connected to ground (PE) on both sides on a large area and with good conductivity.

5 Baud rate setting/line length

The baud rate is not explicitly set. The Profibus component supports the **Auto_Baud** function and independently determines the baud rate set on the bus.

Profibus-DP interface	
Baud rate	max. line length / m
9,6 kBaud	1200
19,2 kBaud	1200
45,45 kBaud	1200
93,75 kBaud	1200
187,5 kBaud	1000
500 kBaud	400
1500 kBaud	200
3000 kBaud	100
6000 kBaud	100
12000 kBaud	100

6 Setting station address

A maximum of 126 slave frequency inverters can be operated on the Profibus-DP. Each frequency inverter is given a node ID for its unambiguous identification; this ID may only exist once in the system. The setting of the node ID is done via the parameter *Profibus Node-ID* **391**.

No.	Parameter	Setting		
	Description	Min.	Max.	Fact. sett.
391	Profibus Node-ID	0	126	126

Note: After the setting of the station address via *Profibus Node-ID* **391**, a reset is automatically triggered on the frequency inverter, by which the setting for the station address is accepted.

7 Setting PPO type

As a function of the application in question, various objects with differing lengths and contents are used for the exchange of data. The objects **PPO1**, **PPO2**, **PPO3** and **PPO4** are available. These objects are set up according to the PROFIDRIVE profile. The required object is to be set on the DP master in the hardware configuration. There is no setting for the required object on the frequency inverter, it sets itself automatically to the projected object.

Profibus - Objects	
PPO type	Objects length / Bytes
1	12
2	20
3	4
4	12

Note: More information on the contents of the objects PPO1 to PPO4, is to be inferred from the chapter "Handling of the objects".

7.1 Configuration process on the DP master

The configuration process of the frequency inverter with the Profibus communication module CM-PDP is displayed here with the example of a Siemens STEP7 hardware configurator. The process is principally valid for other configurations in an equivalent form.

First, the GSD file VEC_0696.GSD is installed in the hardware configurator (if not already existent). This is done with the menu selection **Extras \ Install new GSD**. Here, you enter the path and the name for the GSD file (VEC_0696.GSD).

If the GSD file has been installed, the frequency inverter appears under the selection

PROFIBUS-DP \ Further FIELD DEVICES \ Drives \ ACT 10

From this position, an ACT frequency inverter can now be connected to the required Profibus phase by Drag & Drop.

The four possible objects PPO1 to PPO4 are now visible under the menu point **ACT 10**. The required object is now assigned to the inverter by Drag & Drop.

The screen shot from the STEP7 hardware configuration shows an ACT frequency inverter with the station address 3 and the object PPO2.

Steckplatz	Baugruppe / DP-Kennung	Bestellnummer	E-Adresse	A-Adresse	Kommentar
1	4AX	PPO2: 4 Words PKW, 6 Words PZD	256...263	256...263	
2	77,7	-> PPO2: 4 Words PKW, 6 Words PZD	264...275	264...275	
3					
4					
5					
6					
7					
8					
9					
10					
11					
12					
13					
14					
15					
16					
17					

8 Commands SYNC / FREEZE

The Profibus component supports the Profibus commands SYNC/UNSYNC and FREEZE/UNFREEZE. These commands are used to synchronize a number of slaves.

With the FREEZE command, all the slaves keep their input data. They are then read out in sequence by the bus master. As all the slaves keep their inputs simultaneously with the FREEZE command, the bus master is given a process pattern of all the slaves at a defined time. With the UNFREEZE command, this state is canceled and the slaves update their inputs again.

With the SYNC command, all the slaves keep their outputs. Data arriving subsequently are not put through to the outputs, but buffered. The bus master can give new commands to the slaves and activate all the slaves simultaneously with the UNSYNC command. They immediately take over the buffer data to their outputs with the UNSYNC command.

9 Available objects / scanning times

If a Profibus slave has been recognized, parameterized and convalued by its master on the bus, there is a cyclic exchange of data with the **DATA_EXCHANGE** Profibus service, in which the output data are transmitted from the master to the slave and the input data from the slave to the master **in one cycle**. The repeat rate with which the slaves carry out the exchange of data with the master, the so-called bus rotation time, is a function of the transmission rate set, the number of subscribers and the size of the objects transmitted. If there are few subscribers, a high transmission rate and short objects being exchanged, bus rotation times of 1 to 2 ms are possible.

As it can be seen from what has just been said that the possible bus rotation time also depends to a considerable extent on the size of the objects to be transmitted, the frequency inverter offers a selection between four different objects **PPO1 to PPO4**. In this way, an optimum adaptation to differing situations and requirements is possible.

The objects defined according to PROFIDRIVE principally have two components, which are either completely, partly or not at all existent with the differing objects PPO1 to PPO4. These components are the communication channel and the process data channel.

The **communication channel** is used for access (write/read) to any parameters in the frequency inverter. An exception is formed by the string parameters, to which there can be no access. The communication proceeds according to a firmly defined hand-shake process and lasts for a number of DATA_EXCHANGE cycles.

The **process data channel** is processed in every cycle. The reference values are accepted and the actual values forwarded. A data update thus takes place with every DATA_EXCHANGE.

Direction of transmission Master → Slave (OUT)

communication channel					process data channel				
PKW area					PZD area				
PKE	IND	PWE	PWE	PZD 1	PZD 2	PZD 3	PZD 4	PZD 5	PZD 6
		PWEh	PWEI	STW	HSW	-	-	-	-

PKW Parameter identification value

PZD Process data channel STW = Control word HSW = Main reference value

Direction of transmission Slave → Master (IN)

communication channel					process data channel				
PKW area					PZD area				
PKE	IND	PWE	PWE	PZD 1	PZD 2	PZD 3	PZD 4	PZD 5	PZD 6
		PWEh	PWEI	ZSW	HIW	VAL2	VAL3	VAL4	VAL5

PKW Parameter identification value

PZD Process data channel ZSW = State word HIW = Main actual value

Consistency area

communication channel					process data channel				
PKW area					PZD area				
PKE	IND	PWE	PWE	PZD 1	PZD 2	PZD 3	PZD 4	PZD 5	PZD 6
full length				word	word	word	word	word	word

The statement of the consistency describes the parts of the object which must have consistent contents. The consistency states are encrypted in the configuration data of the GSD file and have effects on the possible access mechanisms on the part of the DP master. In this way, the 8 bytes of the communication channel in a PLC of type Siemens S7 can only be reached via the special functions SFC14 (DPRD_DAT) and SFC15 (DPWR_DAT). The words of the process data channel are directly addressable as periphery words (PEW, PAW).

	communication channel				process data channel					
	PKE	IND	PWEh	PWEI	PZD1	PZD2	PZD3	PZD4	PZD5	PZD6
PPO1										
PPO2										
PPO3										
PPO4										

- The communication channel in PPO1 and PPO2 is treated identically.
- The process data channel PZD1 to PZD6 in PPO2 and PPO4 is firmly defined and its contents cannot be altered.
- The process data channel PZD2 in PPO1 and PPO3 can be altered as regards its contents, controlled via the user-specific bits in the control word STW in the PZD1.

Note: In the data transmission, the **Motorola format** is presupposed for the position of Low/High byte front, as is also supported by a PLC of the type Siemens S7. If the DP master supports the Intel format, Low/High byte are to be swapped on the master side before transmission and after receipt.

Scan time

Regardless of the transmission speed on the Profibus, the scanning time of the inverter is a constant variable as a function of the object used.

PPO3 16 ms
PPO1/2/4 32 ms

An update of the data between the frequency inverter and the Profibus side is done with this scanning time.

10 Handling of the objects

10.1 Communication channel

The communication channel (PKW area) has the following structure:

Designation	PKW Bereich							
	PKE		IND		PWE-high		PWE-low	
Inhalt	Parameter identification		Index		Parameter value High-Word		Parameter value Low-Word	
	High Byte	Low Byte	High Byte	Low Byte	High Byte	Low Byte	High Byte	Low Byte
			Index	0				
Byte No.	0	1	2	3	4	5	6	7

The data are transmitted in the **Motorola format** as, for example, supported by the S7 PLC from Siemens. Thus, the high byte is on the lower byte and the low byte on the higher byte.

Note: The index is always on the high byte of "Index" (Byte No. 2), with the low byte **always = 0**.

Structure of the parameter identification (PKE):																
PKE	High Byte								Low Byte							
Bit	15	14	13	12	11	10	9	8	7	6	5	4	3	2	1	0
	AK				SPM		PNU									

AK: Order or reply identification (value range 0 ..15)

SPM: Toggle bit for spontaneous result processing

PNU: Parameter number (value range 1 to 999)

- The order and reply identifications are stored in the AK area. If no parameter processing is to be done, the **"no order"** kind of function is to be set.
- With bit 11 (SPM), the readiness for spontaneous report processing can be switched on and off (0 = OFF, 1 = ON, in the present application, the spontaneous report processing is not support, so SPM is always 0).
- The PNU area transmits the number of the parameter to be processed.

Parameter values (= data) of the type Integer/Unsigned Integer (16 Bit) and Long (32 Bit) can be written and read. The data type is specific in the order identification. In data set change-over capable parameters (array) the required data set is stated under Index.

Note: An Excel file, which can be requested, exists for the necessary information on the parameters with regard to the data type and data set change-over capacity.

10.1.1 Order identification

Structure of the order identification AK (output data set, Master → Slave)

Order identification AK	Data type	Function
0	-	no order
1	int/uint , long	read parameter value
2	int/uint	write parameter value int/uint
3	long	write parameter value long
6	int/uint , long Array	read parameter value Array
7	int/uint Array	write parameter value int/uint Array
8	long Array	write parameter value long Array

Array: Applies for data set change-over capable parameters; then the required data must be specified in INDEX. Apart from this, INDEX = 0.

10.1.2 Reply identification

Structure of the reply identification AK (input data set, Slave → Master)

Reply identification AK	Data type	Function
0	-	no order
1	int/uint	transmit parameter value int/uint
2	long	transmit parameter value long
4	int/uint Array	transmit parameter value int/uint Array
5	long Array	transmit parameter value long Array
7	-	order cannot be implemented
8	-	no control sovereignty for PKW interface

- If the reply identification = 7 (order cannot be implemented), an error code is inserted in PWE low (Byte 6/7).
- If the reply identification = 8 (no control sovereignty), the master has no writing right onto the slave.

10.1.3 Fault messages

Coding of the fault messages in the reply data set PWE Low/Low Byte at Byte 7 (Slave → Master):

Fault No. (dec.) acc. to PROFIDRIVE	Meaning
0	Inadmissible parameter number PNU
1	Parameter value cannot be altered
2	Lower or upper parameter value limit exceeded
3	Faulty data set
4	no data set change-over capable parameter
5	Wrong data type
18	Other fault

Extension	Meaning
101	Parameter cannot be read
103	Fault occurred in reading the EEPROM
104	Fault occurred in writing the EPROM
105	Check sum fault in EEPROM occurred
106	Parameter may not be written in operation
107	Values of the data sets differ
108	Unknown order

10.1.4 Parameters, data set selection and cyclic writing

Parameters to be set can be seen from the parameter list referring to the configuration of the standard operating instructions. In the parameter list, state whether a parameter is data set change-over capable (data set/INDEX = 1 to 4) or only exists once (data set/INDEX = 0).

The parameter list also gives information about the display format of a parameter and its type (int/uint/long). String parameters cannot be transmitted due to the possible number of bytes.

The values transmitted are always integer values. For values with decimal places, the decimal point is not transmitted.

The word IND passes on the required data set of the parameter. In the present application, the parameter set number 0 is simply assigned to existing parameters; a selection from multiple (data set change-over capable) existing parameters is done by inputting a number from 1 to 4.

The actual parameter value is transmitted in the PWE area; as a 16 Bit value (int/uint) it occupies PWEI, as a 32 Bit value (long) PWE high and PWE low, with the high word being in PWE high.

Typically, parameters are addressed via the data set (IND) = 0, 1 to 4. The input of the values is thus done on the controller and automatically into the EEPROM. If values are written cyclically with a higher repeat rate, no entry may be made into the EEPROM, as the latter only possesses a limited number of admissible writing cycles (approx. 1 million cycles).



Caution: If the number of admissible writing cycles is exceeded, the EEPROM is destroyed.

To avoid this, cyclically written data can only be transmitted into the RAM without a writing cycle onto the EEPROM. The data are then not stored secure against zero voltage and must be written again after a Power off/on.

This mechanism is activated by the target data set being increased by five in the specification of the data set (IND).

Entry only into the RAM:	
EEPROM	RAM
Entry into data set 0	Data set (IND) = 5
Entry into data set 1	Data set (IND) = 6
Entry into data set 2	Data set (IND) = 7
Entry into data set 3	Data set (IND) = 8
Entry into data set 4	Data set (IND) = 9

Writing access to data set change-over capable parameters is to be considered as a further special point. If the values of a data set change-over capable parameter are to be set to the same value in all data sets, the parameter can be written via the data set (IND) 0.

10.1.5 Sequence of communication

An order of the master is **always** answered by a reply from the slave. Each PPO can always only accept one order or one reply. In this way, a defined hand-shake procedure between master and slave is to be complied with.

In the initial situation, order **and** reply identification must = 0. The master sets its order identification and waits for the slave to change the reply identification from 0 to $\neq 0$. Now, the reply from the slave is available and can be evaluated. Thereupon, the master sets its order identification = 0 and waits for the slave to change the reply identification from $\neq 0$ to 0. With this, the communication cycle is completed and a new one can start.

Attention: The slave only replies to new orders if it has reacted to the order identification = 0 with the reply identification = 0.

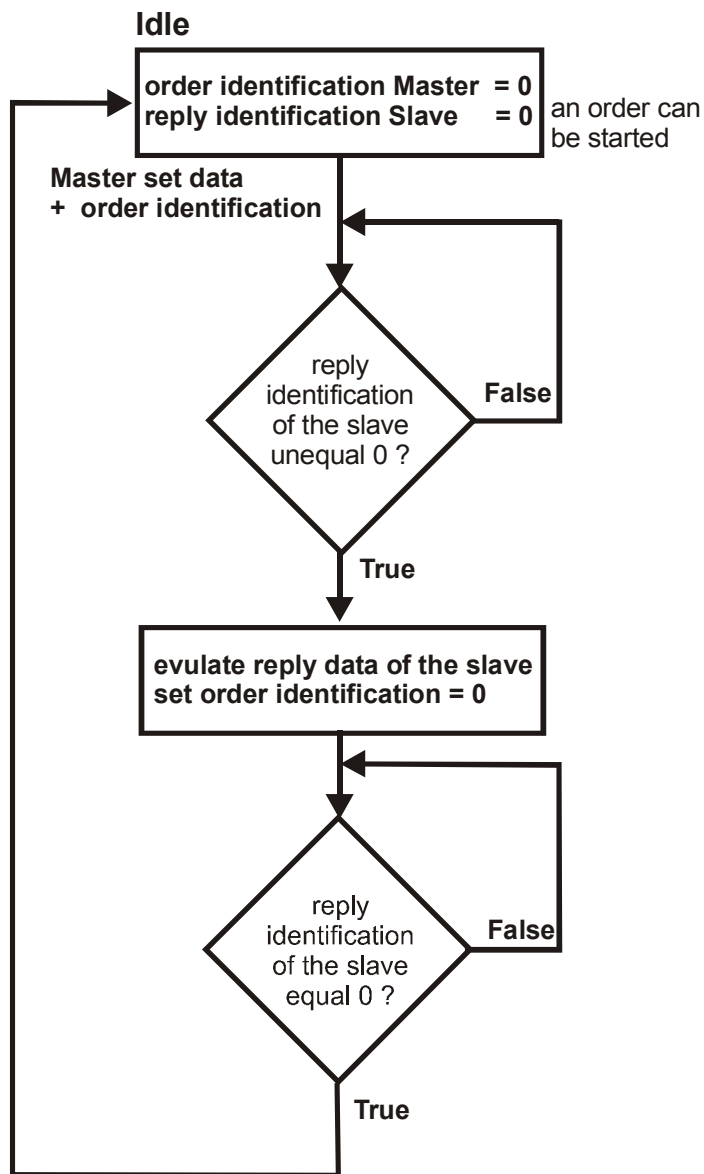

10.1.6 Examples of communication

Parameter					Setting		
No.	Description	Type	Write / Read	Format	Min.	Max.	Fact. sett.
400	Switching frequency	P-W	S/L	x	1	8	2
480	Fixed frequency 1	P[I]-D	S/L	xxxx.xx Hz	-999.00	999.00	5.00

Parameter 400 is one word (P-W), int, not data set switch-over capable and is to be read.

Order from Master:

AK = 1 (order identification = read parameter value)
 PNU = 400 (= 0x190)
 IND = 0
 PWEh = 0
 PWEI = 0

PKW area								
Designation	PKE		IND		PWE high		PWE low	
Content	Parameter identification		Index		Parameter value High Word		Parameter value Low Word	
	High Byte	Low Byte	High Byte	Low Byte	High Byte	Low Byte	High Byte	Low Byte
	0x11	0x90	0	0	0	0	0	0
Byte No.	0	1	2	3	4	5	6	7

Reply from Slave:

AK = 1 (reply identification = transmit parameter value int/uint)
 PNU = 400 (= 0x190)
 IND = 0
 PWEh = 0
 PWEI = value

PKW area								
Designation	PKE		IND		PWE high		PWE low	
Content	Parameter identification		Index		Parameter value High Word		Parameter value Low Word	
	High Byte	Low Byte	High Byte	Low Byte	High Byte	Low Byte	High Byte	Low Byte
	0x11	0x90	0	0	0	0	0	Wert
Byte No.	0	1	2	3	4	5	6	7

VECTRON

Parameter 480 is a double word (P[I]-D), long, data set change-over capable and is to be written. The target data set is data set 3.

Reference value = -300.00 Hz (-30000 is transmitted)

The negative value is portrayed as follows in accordance with integer arithmetic:
0xFFFF8AD0

Order from Master:

AK = 8 (order identification = write parameter value long Array)
 PNU = 480 (= 0x1E0)
 IND = 3
 PWEh = 0xFFFF
 PWEI = 0x8AD0

PKW area								
Designation	PKE		IND		PWE high		PWE low	
Content	Parameter identification		Index		Parameter value High Word		Parameter value Low Word	
	High Byte	Low Byte	High Byte	Low Byte	High Byte	Low Byte	High Byte	Low Byte
	0x81	0xE0	3	0	0xFF	0xFF	0x8A	0xD0
Byte No.	0	1	2	3	4	5	6	7

Reply from Slave:

AK = 5 (reply identification = transmit parameter value long Array)
 PNU = 480 (= 0x1E0)
 IND = 3
 PWEh = 0xFFFF
 PWEI = 0x8AD0

PKW area								
Designation	PKE		IND		PWE high		PWE low	
Content	Parameter identification		Index		Parameter value High Word		Parameter value Low Word	
	High Byte	Low Byte	High Byte	Low Byte	High Byte	Low Byte	High Byte	Low Byte
	0x51	0xE0	3	0	0xFF	0xFF	0x8A	0xD0
Byte No.	0	1	2	3	4	5	6	7

10.2 Process data channel PZD1/PZD2

In this chapter, the basic functions of the PZD1 and PZD2, which are identical for all the objects PPO1 to PPO4, are described.

10.2.1 PZD1, control word / state word

In PZD1, the master gives its control commands (control word) to the frequency inverter in the output data set and gets the information about its state (state word) in the input data set.

The control of the frequency inverter can be done with three differing operation modes. They are set via the data set change-over capable parameter *Local/Remote* **412**.

Parameter		Setting		
No.	Description	Min.	Max.	Fact. sett.
412	Local/Remote	0	44	44

For operation on the Profibus, only the settings 0, 1 and 2 are relevant. The further settings relate to the possibilities of control via the KP500 control unit.

Operation mode	Function
0 - Control via contacts	The Start and Stop command as well as the statement of the direction of rotation are via digital signals.
1 - Control via state machine	The Start and Stop command as well as the statement of the direction of rotation are via the DRIVECOM State machine of the communication interface.
2 - Control via remote contacts	The Start and Stop command as well as the statement of the direction of rotation are via logic signals by the communication protocol.

Control word STW and state word ZSW have differing contents as a function of the operation mode. In each case, all or only some of the bits in the control word are relevant and also only certain feedbacks are possible via the status word. These are then explained in the descriptions of the three possible operation modes.

Control and state word have been created according to DRIVECOM. In this way, there is compatibility to PROFIDRIVE.

Note: The parameter *Local/Remote* **412** is data set change-over capable. Thus, switching over between various operation modes via the data set selection is possible. For example, it is possible to control an frequency inverter via the bus and to activate a local emergency operation if the bus master breaks down. This switch-over is also visible via the state word (Bit Remote).

The data set change-over can be done locally at the frequency inverter via contact inputs or via the bus. For the data set change-over via the bus, the parameter *Data set selection* **414** is used.

Parameter		Setting		
No.	Description	Min.	Max.	Fact. sett.
414	Data set selection	0	4	0

With *Data set selection* **414** = 0, the data set switch-over via contact inputs is active. If *Data set selection* **414** has been set to 1, 2, 3, or 4, the data set selected in this way has been activated. The data set switch-over via the contact inputs is then deactivated.

Via the parameter *Active data set 249* the data set currently selected can be read out. *Active data set 249* states the activated data set with the value 1, 2, 3 or 4. This is independent of whether the data set change-over has been done via control inputs or via *Data set selection 414*.

10.2.2 Control via contacts

In the operation mode control via contacts (*Local/Remote 412* = 0) the frequency inverter is controlled via the contact inputs S2IND to S6IND. The meaning of these inputs can be seen from the operating instructions. The control word in PZD1 is not relevant for this operation mode.

State machine:

The values contained in the states report the feedback about the state word (Bit 0 to Bit 6) in PZD1.

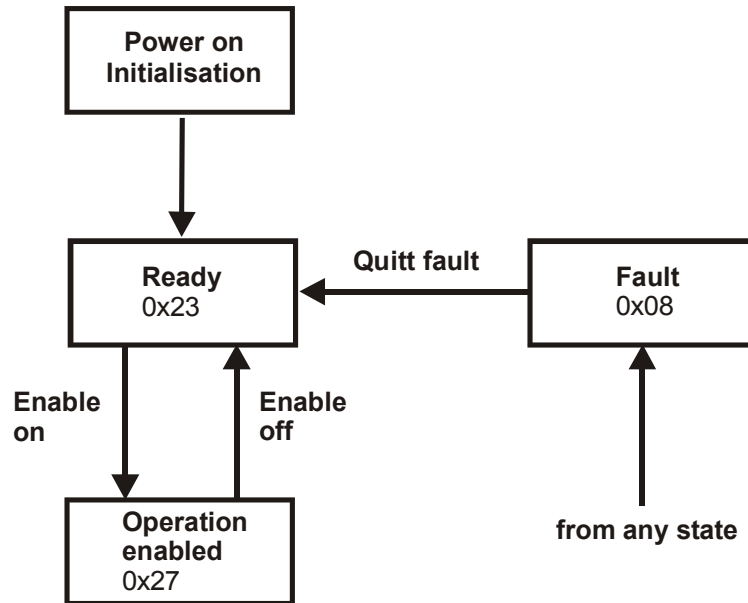

Control word	
Bit No.	Name
0	-
1	-
2	-
3	-
4	-
5	-
6	-
7	-
8	-
9	-
10	-
11	-
12	IW1 → chapter 10.2.6
13	IW2 → chapter 10.2.6
14	IW3 → chapter 10.2.6
15	-

State word	
Bit No.	Name
0	Ready to switch on
1	Ready
2	Operation enabled
3	Fault
4	Voltage -inhibited
5	Quick-stop
6	Switch on inhibit
7	Warning
8	-
9	Remote
10	Reference value reached
11	Limit value reached
12	IW1 → chapter 10.2.6
13	IW2 → chapter 10.2.6
14	IW3 → chapter 10.2.6
15	Warning 2

The state word reflects the operation state.

State word							
State	HEX (*)	Bit 6	Bit 5	Bit 3	Bit 2	Bit 1	Bit 0
Ready	0x23	0	1	0	0	1	1
Operation enabled	0x27	0	1	0	1	1	1
Fault	0x08	0	x	1	0	0	0

(*)without considering bits 7 to bit 15

Note: A fault occurring leads to a switch-over to the "Fault" state.
A fault can only be acknowledged 15 seconds after the occurrence of the fault, as a blocking time is active internally.

The **Warning bit "Bit No. 7"** can be set at any time. It displays an device-internal warning message. The evaluation of the warning available is done by reading out the warning status with the parameter *Warnings* **270**.

The **Remote bit "Bit No. 9"** is always = 0.

The bit **Reference value reached "Bit No. 10"** is set when the reference value specified has been reached. In the special case of power failure regulation, the bit is also set if the power failure regulation has reached the frequency 0 Hz (see operating instructions). For "Reference value reached" there is a hysteresis (tolerance range), which can be set via the parameter *max. Control deviation* **549** (see operating instructions).

The bit **Limit value active "Bit No. 11"** displays that an internal limit is active. This can, for example, be the present current limit, the torque limit or the overvoltage limit. All the functions lead to the reference value being quit or not reached.

The bit **Warning 2 "Bit No. 15"** reports a warning which leads to a fault switch-off of the frequency inverter within a short time. This bit is set if there is a warning for motor temperature, heat sink/inside temperature, Ixt monitoring or mains phase failure.

10.2.3 Control via state machine

In the operation mode control via state machine (*Local/Remote* **412** = 1) the frequency inverter is controlled via the control word in PZD1. The possible states are shown in the diagram. The values on the transition identify these transitions between the states. The codes shown on the transitions, 0xnn, are the control word needed in each case (Bit 0 to Bit 7). The codes contained in the states, 0xnn, display the contents of the state word (Bit 0 to Bit 7).

After mains on (Reset), the frequency inverter is in the state "Switch-on inhibit" (0x40). With the transitions 4 and 5, there is a change between "Operation enabled" (0x27, power parts enabled, drive working) and "Ready" (0x23, power parts blocked).

Release (transition 4) is only possible if the hardware release is available via contact inputs S1IND/FUF **AND** (S2IND/STR **OR** S3IND/STL). They can be firmly wired or also firmly connected to On/Off via the configuration of the digital inputs. If contact input S1IND/FUF is switched off, the inverter outputs can be blocked at any time. The drive then stops freely. There is a transition to "Ready" (0x23, power parts blocked).

The behavior of transition 5 can be set via the parameter *State transition 5* **392**. Here, free stopping, shutdown via ramp (reversible) or DC braking (see Chapter " Behavior in transition 5") can be used.

State machine:

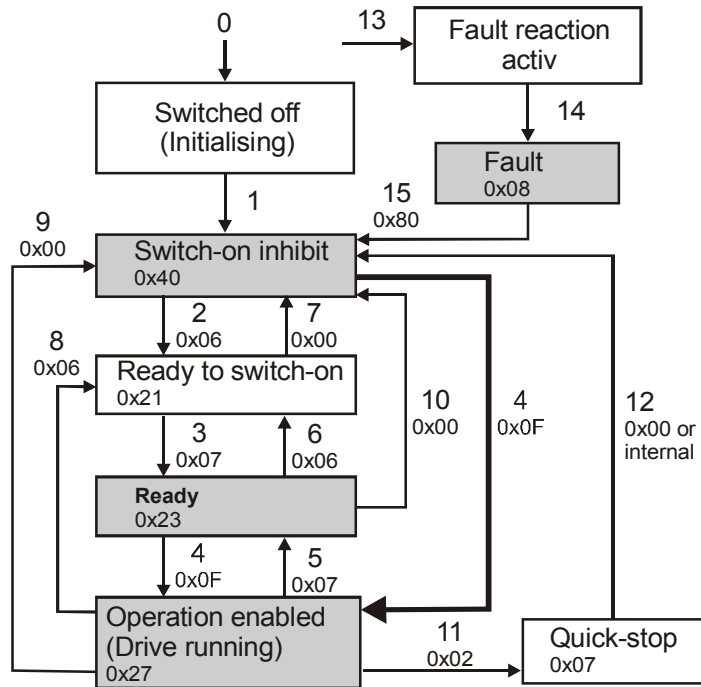

Control word	
Bit No.	Name
0	Switch on
1	Voltage-inhibit
2	Quick stop
3	Operation-enabled
4	-
5	-
6	-
7	Reset-fault

Control word	
Bit No.	Name
8	-
9	-
10	-
11	-
12	IW1 → chapter 10.2.3
13	IW2 → chapter 10.2.3
14	IW3 → chapter 10.2.3
15	-

Control commands

The device control commands are triggered by the following bit combinations in the control word:

Control word							
Command	HEX	Bit 7	Bit 3	Bit 2	Bit 1	Bit 0	Transition
Shutdown	0x06	X	X	1	1	0	2, 6, 8
Switch-on	0x07	X	X	1	1	1	3
Voltage-inhibit	0x00	X	X	X	0	X	7, 9, 10
Quick-stop	0x02	X	X	0	1	X	11
Operation-inhibit	0x07	X	0	1	1	1	5
Operation enabled	0x0F	X	1	1	1	1	4
Reset faults	0x80	0 ⇔ 1	x	x	x	x	15

To make operation of the device simpler, a simplification has been implemented in the extension to the state machine defined under DRIVECOM. An additional transition from "Switch-on inhibit" to "Operation enabled" exists.

The shaded commands are the commands relevant for the simplified state machine.

Note: A fault occurring leads to a switch-over to the "Fault" state. The acknowledge of the fault is done by a positive edge of Bit 7.
 A fault can only be acknowledged 15 seconds after the occurrence of the fault, as a blocking time is active internally.

State word		State word	
Bit No.	Name	Bit No.	Name
0	Ready to switch on	8	-
1	Ready	9	Remote
2	Operation enabled	10	Reference value reached
3	Fault	11	Limit value reached
4	Voltage inhibit	12	IW1 → chapter 10.2.3.
5	Quick stop	13	IW2 → chapter 10.2.3.
6	switch on inhibit	14	IW3 → chapter 10.2.3.
7	Warning	15	Warning 2

The state word reflects the operation state.

State word							
Meaning	HEX (*)	Bit 6	Bit 5	Bit 3	Bit 2	Bit 1	Bit 0
Switched-off	0x00	0	x	0	0	0	0
Switch-on inhibit	0x40	1	x	0	0	0	0
Ready to switch-on	0x21	0	1	0	0	0	1
Quick-stop	0x07	0	0	0	1	1	1
Ready	0x23	0	1	0	0	1	1
Operation enabled	0x27	0	1	0	1	1	1
Fault	0x08	0	x	1	0	0	0
Fault reaction active	0x0F	0	x	1	1	1	1

(*) without considering bits 7 to bit 15

The shaded commands are the commands relevant for the simplified state machine.

The **Warning bit "Bit No. 7"** can be set at any time. It displays an device-internal warning message. The evaluation of the warning available is done by reading out the warning status with the parameter *Warnings 270*.

The **Remote bit "Bit No. 9"** is set if the operation mode control via state machine (*Local/Remote 412* = 1) has been set **and** the hardware release is available.

Logic linking of the digital control signals:

$$(S1IND \text{ AND } (S2IND \text{ OR } S3IND))$$

Only if the logic linking is true the frequency inverter can be controlled via the control word.

The bit **Reference value reached "Bit No. 10"** is set when the reference value specified has been reached. In the special case of power failure regulation, the bit is also set if the power failure regulation has reached the frequency 0 Hz (see operating instructions). For "Reference value reached" there is a hysteresis (tolerance range), which can be set via the parameter *max. Control deviation 549* (see operating instructions).

The bit **Limit value active "Bit No. 11"** displays that an internal limit is active. This can, for example, be the present current limit, the torque limit or the overvoltage limit. All the functions lead to the reference value being quit or not reached.

The bit **Warning 2 "Bit No. 15"** reports a warning which leads to a fault switch-off of the frequency inverter within a short time. This bit is set if there is a warning for motor temperature, heat sink/inside temperature, Ixt monitoring or mains phase failure.

10.2.3.1 Behavior in quick stop

In this, the parameters *Switch-off threshold* **637** (percent of f_{max}) and *Holding time* **638** (holding time after falling short of the switch-off threshold) are relevant. In a quick stop, the drive is shutdown via the emergency stop ramps (*Emergency stop clockwise* **424** or *Emergency stop anti-clockwise* **425**).

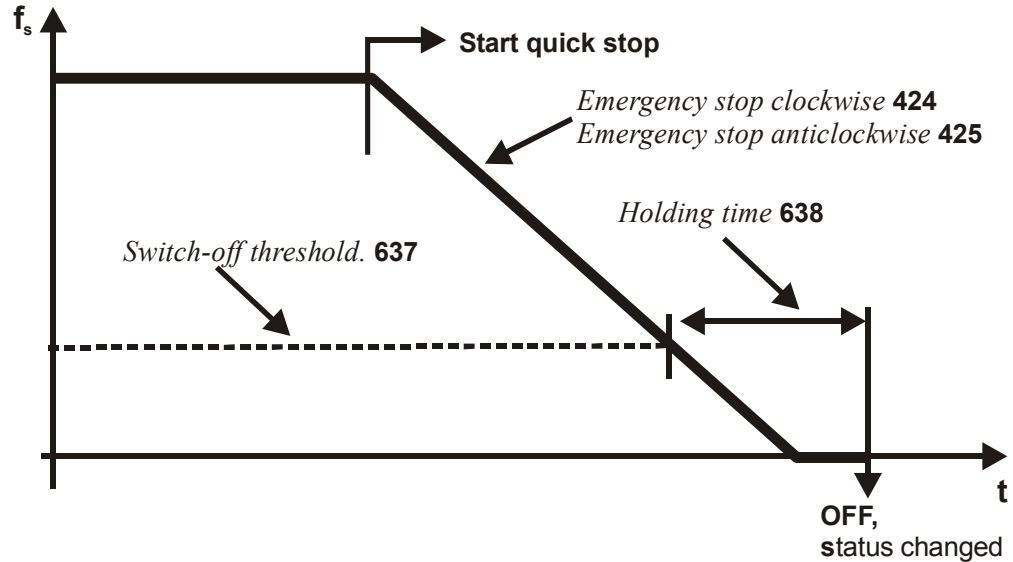

If frequency/speed zero has been reached during the holding time, the drive continues to be supplied with direct current until the switch-off time has expired. With this measure, there is an assurance that the drive is stationary in a change of state.

10.2.3.2 Behavior in transition 5

The behavior in transition 5 from "Operation enabled" to "Switched on" can be parameterized. The behavior is set via parameter *State transition 5* **392**.

Parameter		Setting		
No.	Description	Min.	Max.	Fact. sett.
392	State transition 5	0	2	2

Operation mode	Function
0 - Coast to stop	immediate transition from "Operation enabled" to "Ready", free stoppage of the drive
1 - DC brake	activation of DC brake, with the end of DC braking, there is the change from "Operation enabled" to "Ready"
2 - Ramp	transmission with normal stop ramp, after reaching standstill, there is a change from "Operation enabled" to "Ready"

Note: Setting operation mode "1 - DC brake" is only possible in applications with v/f characteristic (e.g. configuration 110), as other applications do not know such an operation mode.

If the frequency inverter is operated with a configuration which does not know the DC braking operation mode (e.g. configuration 210, field-orientation speed controlled), value "1" cannot be set. It is also not offered in the selection menus of the KP500 control unit or the VPlus program.

Note: The default value for the parameter *State transition 5 392* is operation mode "2 – Ramp". For configurations with torque control, the default value is operation mode "0 - Coast to stop". In a switch-over of the configuration, the setting value for *State transition 5 392* is also altered if necessary.

If transition 5 has been triggered with *State transition 5 392* = "1 - DC brake", a new control word is only accepted after the completion of the transition process. The change of state from "Operation enabled" to "Ready" is done after the expiry of the time *Braking time 632* parameterized for the DC brake.

If the parameter *State transition 5 392* = "2 - Ramp" has been set, the control word can be set back to 0x0F during the stoppage of the drive. In this way, the drive runs back up to its set reference value and remains in the state "Operation enabled".

The change of state from "Operation enabled" to "Ready" is done after the set switch-off threshold has been reached **and** expiry of the set holding time (equivalent to the behavior in a quick stop). In this, the parameters *Switch-off threshold 637* (percent of fmax) and *Holding time 638* (holding time after switch-off threshold reached) are relevant.

10.2.4 Control via remote contacts

In the operation mode *Local/Remote 412* = "2 - Control via remote contacts" the frequency inverter is controlled via the control word in PZD1, with the bits 0 to 5 corresponding to the contact inputs S1IND to S6IND. In addition, two virtual contact inputs S7IND and S8IND are available. These virtual contact inputs are not supported as a standard feature and are reserved for special applications. In the use of the remote contact, the frequency inverter behaves in the same way as in control via the hardware contact inputs. The meaning of these inputs can be seen from the operating instructions.

Note: Release is only possible if the hardware release is available via digital input S1IND.

State machine:

The values in the states report the feedback message via the state word (Bit 0 to 6) in PZD1.

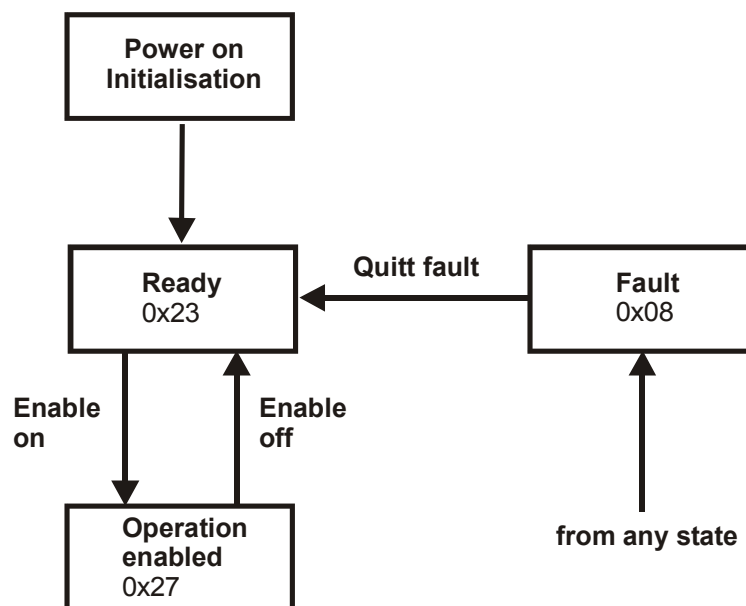

Note: The inputs set via the control word can be observed with the help of parameter *Digital Inputs 250*. Digital input S1IND is only displayed as being set if the hardware release is available **and** the control word / Bit 0 has been set.
 If the data set switch-over is used, please make sure that the parameter *Local/Remote 412* is set to operation mode "2 - Control via remote contacts" in all the data sets used.

Control word	
Bit No.	Name
0	S1IND / FUF
1	S2IND
2	S3IND
3	S4IND
4	S5IND
5	S6IND
6	S7IND
7	S8IND
8	-
9	-
10	-
11	-
12	IW1 → chapter 10.2.6
13	IW2 → chapter 10.2.6
14	IW3 → chapter 10.2.6
15	-

State word	
Bit No.	Name
0	Ready to switch on
1	Ready
2	Operation enabled
3	Fault
4	Voltage-inhibit
5	Quick stop
6	Switch on inhibit
7	Warning
8	-
9	Remote
10	Reference value reached
11	Limit value reached
12	IW1 → chapter 10.2.6
13	IW2 → chapter 10.2.6
14	IW3 → chapter 10.2.6
15	Warning 2

State word							
State	HEX (*)	Bit 6	Bit 5	Bit 3	Bit 2	Bit 1	Bit 0
Ready	0x23	0	1	0	0	1	1
Operation enabled	0x27	0	1	0	1	1	1
Fault	0x08	0	x	1	0	0	0

(*) without considering bits 7 to bit 15

Note: A fault occurring leads to a switch-over to the "Fault" state.
 A fault can only be acknowledged 15 seconds after the occurrence of the fault, as a blocking time is active internally.

The **Warning bit "Bit No. 7"** can be set at any time. It displays an device-internal warning message. The evaluation of the warning available is done by reading out the warning status with the parameter *Warnings 270*.

The **Remote bit "Bit No. 9"** is set if the operation mode control via remote contacts (*Local/Remote 412* = 2) has been set **and** the hardware release is available (S1IND = 1). Only then can the frequency inverter be controlled via the control word.

The bit **Reference value reached "Bit No. 10"** is set when the reference value specified has been reached. In the special case of power failure regulation, the bit is also set if the power failure regulation has reached the frequency 0 Hz (see operating instructions). For "Reference value reached" there is a hysteresis (tolerance range), which can be set via the parameter *max. Control deviation 549* (see operating instructions).

The bit **Limit value active "Bit No. 11"** displays that an internal limit is active. This can, for example, be the present current limit, the torque limit or the overvoltage limit. All the functions lead to the reference value being quit or not reached.

The bit **Warning 2 "Bit No. 15"** reports a warning which leads to a fault switch-off of the frequency inverter within a short time. This bit is set if there is a warning for motor temperature, heat sink/inside temperature, Ixt monitoring or mains phase failure.

10.2.5 PZD2, reference value / actual value

In the PZD2, the master gives its reference value to the frequency inverter in the output data set and gets information back about its actual value in the input data set.

The use of the reference/actual value channel is a function of the configuration set (control system). The actual value is generated from the correct source in question as a function of the control system used.

Note: The reference value and actual value are referenced to the parameter *Rated frequency 375 OR* the parameter *Profibus Reference 390*.

The distinction is made via the setting of the parameter *Profibus Reference 390*. If *Profibus Reference 390 = 0*, *Rated frequency 375* is the reference variable. If *Profibus Reference 390 ≠ 0*, *Profibus Reference 390* is used as the reference variable. Both parameters are data set switch-over capable.

Parameter		Setting		
No.	Description	Min.	Max.	Fact. Sett.
375	Rated frequency	10.00 Hz	1000.00 Hz	50.00 Hz
390	Profibus Reference	0.00 Hz	999.99 Hz	0.00 Hz

Reference and actual values are transmitted in a standardized form. The standardization is done by the variables being related to the reference value (*Rated frequency 375 OR Profibus reference 390*).

Standardization			
Reference value	Binary	Decimal	Hexadecimal
+ 100 %	+ 2 ¹⁴	16384	0x4000
- 100 %	- 2 ¹⁴	49152	0xC000

The possible range = ±200 % = +32768 to -32768 = 0x8000 to 0x7FFF

Example: The setting of the parameter *Profibus Reference 390* is the reference value 60.00 Hz. The required reference frequency is 30.00 Hz. This means 50 % of the reference value, and thus the set point 8192 either 0x2000 has to be transmitted.

With the reference value *Profibus Reference 390* a machine can also be operated in the field weakening area above its reference frequency.

Example: The parameter *Rated frequency 375* is set to a frequency of 50.00 Hz. With the setting of the parameter *Profibus Reference 390* to 100.00 Hz the value range of ± 200 Hz is possible.

The reference value for the frequency inverter from PZD2 is included via the line set point value. This reference value is combined with the internal set point value from the reference frequency channel in the input of the ramp function. For the reference frequency channel, see the operating instructions.

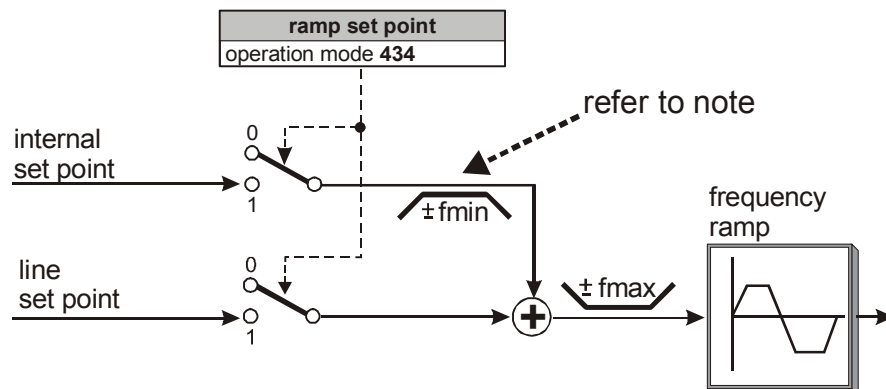

The internal set point value from the reference frequency channel and the line set point value can be guided to the ramp individually or an added variable. The setting is done via the data set change-over capable parameter *Ramp set point 434*.

Parameter		Setting		
Nr.	Description	Min.	Max.	Fact. sett.
434	Ramp set point	1	3	3

Operation mode		Function
0 -	Internal set point	Reference value from the source percent or frequency reference value channel
1 -	Line set point"	Reference value from the communication interface
2 -	Internal + line set point	Reference sum of internal set point and line set point

The reference value can be controlled on the frequency inverter via the KP500 control unit or the VPlus program.

Note: If *Ramp set point 434* = 2 (only line set point value), this reference line value is limited to *fmin*. Please remember that the sign in front of *fmin* at reference value = 0 is derived from the sign in front of the last line set point value $\neq 0$.
After Power on, the reference line value is limited to +*fmin* !

For *Ramp set point 434* = 3 the sign in front of the overall reference value results from the sum of internal + line set point value.

Actual values		
Parameter	Content	Format
<i>Internal reference frequency 228</i>	internal set point value from reference frequency channel	xxx.xx Hz
<i>Reference bus frequency 282</i>	line set point value from Profibus	xxx.xx Hz
<i>Reference ramp frequency 283</i>	sum of internal set point value + line set point value	xxx.xx Hz

10.2.6 Variable actual value reporting via PZD2 in PPO1 / PPO3

In the objects PPO1 and PPO3, only the PZD2 is available for reporting of actual values. There, the actual value (actual frequency) is displayed as a standard feature. In order to be able to display further actual values via the PZD2, the actual value is controlled via the bits 12 ... 14 = IW1 ... IW3 in the control word (PZD1). This is done regardless of the kind of controls.

Actual value message			
Control word / State word			Content PZD2 actual value
IW3	IW2	IW1	
Bit 14	Bit 13	Bit 12	
0	0	0	Actual frequency (stator or sensor frequency)
0	0	1	Abs. current (r.m.s current)
0	1	0	Active current or torque-forming current
1	0	1	Warning (bit-coded, see Annex)
1	1	0	Fault (see Annex)

In the state word, the current actual value is reported via the bits 12 ... 14 = IW1 ... IW3. Other settings than those above result in the actual frequency as the content of PZD2 actual value (matching the setting Bit 12 ... 14 = 0, standard).

On the basis of the property of the data exchange between master and slave via the DATA_EXCHANGE service, there must be an evaluation in the state word on the master's side of the actual value available in PZD2. In DATA_EXCHANGE, the output data of the master are written and the input data read in one cycle. The input data are calculated in the previous cycle and temporarily stored in buffers. From these buffers, they are then read in the DATA_EXCHANGE. This is why at least one cycle is necessary in order to switch the actual values over on the device side.

Note: The displayed "active current" or "torque-forming current" is a function of the control system in question. In field-orientation, the torque-forming current is displayed, in applications with a v/f characteristic control, the active current, which is also a measure for the torque.
 The abs. current (r.m.s. current) is always positive. Active current or torque-forming current have a sign in front.
 Positive currents = motor
 Negative currents = generator operation.

Current scaling:

Standardization			
Reference value	Binary	Decimal	Hexadecimal
+ 100 %	+ 2 ¹⁴	16384	0x4000

The possible range = ±200 % = +32768 to -32768 = 0x8000 to 0x7FFF

For the standardization the data set change-over capable parameter *Rated frequency 371* is used as a reference value.

Parameter		Setting		
Nr.	Description	Min.	Max.	Fact. Sett.
371	Rated current	0,01 · I _{FIN}	10 · I _{FIN}	I _{FIN}

10.2.7 Actual value report PZD2 to PZD6 in PPO2 / PPO4

For the components of process data channel PZD2 to PZD6 existing in the objects PPO2 and PPO4, the variably settable actual values for the objects PPO1 and PPO3 are displayed.

Actual value message	
PZD1	State word
PZD2	Actual frequency
PZD3	Abs. current
PZD4	Active current or torque-forming current
PZD5	Warning (bit-coded, see Annex)
PZD6	Fault (see Annex)

The scaling of the values is identical to the descriptions in the previous chapters..

The control bits IW1 ... IW3 in the control word (PZD1) are ineffective here. Entries at this point have no effects and are not reported via the state word.

10.2.8 PPO-Out data as global sources

Note: The functions described in this chapter are available from software version 4.0.5.

In the use of the Profibus-DP, the user has four different objects at his disposal for data transmission between DP master and frequency inverter inverter (see Chapter 9). Objects PPO2 and PPO4 have output data, which are provided as global data sources in the frequency inverter, in the PZD3 - PZD6.

	Communication channel				Process data channel					
	PKE	IND	PWEh	PWEI	PZD1	PZD2	PZD3	PZD4	PZD5	PZD6
PPO2										
PPO4										

This results in new functions for the user, some examples of which are listed here:

- specification of reference value and / or actual value for the technology controller (as a percentage)
- position commands for digital outputs (as Boolean)
- data set change-over / switch-over fixed frequencies (as Boolean)
- additional reference frequencies (as reference values in Profidrive notation)
- additional reference torques / reference currents for field-oriented applications (as word in internal notation)

As the consistency conditions for the components PZDx have been defined as "consistent via word" in the object definitions of the GSD file, a direct access by means of "write periphery word" is possible on the part of the PLC. The application within the PLC is thus made very simple. The additional benefit is the very quick processing of the PZD channel, with which the applications on the frequency inverter side are provided with permanently updated data.

Note: For the use of the PPO-Out data as sources for function inputs, it may be necessary, depending on the function used, to load configuration-dependent XPI files for the VPlus program, for example swc_111.xpi for configuration 111, technology controller.

The data OUT-PZD3 - 6 in PPO2 and PPO4 are defined as sources. Each of OUT-PZD3 - 6 is a word (16 Bit).

The sources are structured according to the table:

	Source no. Boolean value		Source no. uint/int value		Source no. Long value
OUT-PZD3	750 Boolean	OUT-PZD3	754 Word	OUT-PZD3	758 Long
OUT-PZD4	751 Boolean	OUT-PZD4	755 Word	OUT-PZD4	759 Long
OUT-PZD5	752 Boolean	OUT-PZD5	756 Word	OUT-PZD5	760 Long
OUT-PZD6	753 Boolean	OUT-PZD6	757 Word	OUT-PZD6	761 Long

The designation of the sources in the selection lists is thus:

Sources	
Source no.	Designation
750	OUT-PZD3 Boolean
751	OUT-PZD4 Boolean
752	OUT-PZD5 Boolean
753	OUT-PZD6 Boolean
754	OUT-PZD3 Word
755	OUT-PZD4 Word
756	OUT-PZD5 Word
757	OUT-PZD6 Word
758	OUT-PZD3 Long
759	OUT-PZD5 Long
759	OUT-PZD6 Long
760	OUT-PZD7 Long

Note: The sources are only available if a CM-PDP communication module exists in the frequency inverter AND the PPO2 or PPO4 is projected as the transmission object.
 Each source can only be used once with a specification (Boolean, Word, long).
 If the frequency inverter has additionally been equipped with the EM-SYS system bus module, the Profibus sources "OUT-PZDx" can also be transported via the system bus.

The data OUT-PZD3 - 6 can be used as sources for various data types / applications. Depending on the application, the necessary data format (notation) is to be observed. They are described below.

Note: In the data formats on the part of the PLC, the Motorola format (MSB first), as used for example by the Siemens S7, is presupposed.

Boolean data type

The Boolean data type is used for logical functions. In addition, for example, signals such as Clockwise/Anti-clockwise start, data set switch-over or timer inputs can be operated or digital outputs be set directly.

The Boolean data type can be displayed via a 16-Bit word in OUT-PZD3 - 6.

Boolean data type			
	data content hexadecimal	data content decimal	logical interpretation
OUT-PZDn	0x0000	0	FALSE / AUS
OUT-PZDn	0xFFFF	65535	TRUE / EIN

n = 3, 4, 5 or 6

Word data type

The Word data type can be used for the variables percentage, current and torque. Current and torque are possible in applications with field-orientation. The scaling in question are described below.

Word data type – Percent

The value range for percentage values is -300.00 to +300.00 %. Display in OUT-PZDn is done with an extension factor of 100.

Word data type – Percent			
	data content hexadecimal	data content decimal	logical interpretation
OUT-PZDn	0x8AD0	- 30000	- 300,00 %
OUT-PZDn	0x0000	0	0,00 %
OUT-PZDn	0x7530	+ 30000	+ 300,00 %

n = 3, 4, 5 or 6

Example:

Set point = +30,00 % OUT-PZDn = 0x0BB8 (hexadecimal) = 3000 (decimal)
 Set point = -55,36 % OUT-PZDn = 0xEA60 (hexadecimal) = -5536 (decimal)

Word data type – Current

For the current, calculation must be done in the device-internal scaling. The scaling is:

$$\text{Reference value} = (\text{Reference current[A]} / \text{scaling current[A]}) \cdot 2^{13}$$

$$2^{13} = 8192 \text{ (decimal)} = 0x2000 \text{ (hexadecimal)}$$

Word data type – Torque

For the torque specification, calculation must be done in the device-internal scaling. The scaling for a torque is identical to the specification of the reference current (see Current). If the machine is operated with nominal flux, a reference torque corresponds to a reference current.

Note: The equation stated for current (torque) applies for operation with nominal flux. If a machine is operated in the field weakening area, this is to be considered in the specification values.

If the variables current or torque are used, please regard to the device-specific scaling.

Long data type

The Long data type is used for specification of frequencies. The same notation is used here in the reference value specification via PZD3 to 6 as for the standard reference channel via PZD2.

The reference value is referenced to the parameter *Rated frequency 375* OR the parameter *Profibus Reference 390*.

The distinction is made via the setting of the parameter *Profibus Reference 390*. If *Profibus Reference 390* = 0, *Rated frequency 375* is the reference variable. If *Profibus Reference 390* ≠ 0, *Profibus Reference 390* is used as the reference variable. Both parameters are data set switch-over capable.

Parameter		Setting		
Nr.	Description	Min.	Max.	Fact. sett.
375	Rated frequency	10.00	1000.00	50.00
390	Profibus Reference	0.00	999.99	0.00

Reference and actual values are transmitted in a standardized form. The standardization is done by the variables being related to the reference value (*Rated frequency 375 OR Profibus reference 390*).

According to PROFIDRIVE the standardization is fixed as:

Standardization			
Reference value	Binary	Decimal	Hexadecimal
+ 100 %	+ 2 ¹⁴	16384	0x4000
- 100 %	- 2 ¹⁴	49152	0xC000

The possible range = ±200 % = +32768 to -32768 = 0x8000 to 0x7FFF

Example:

Reference = *Profibus Reference 390* = 60.00 Hz, reference value via PZD5

required reference frequency = 30.00 Hz = 50% of the reference value
transmitted reference value in PZD5 = 8192 = 0x2000

Accordingly, this reference value is available via the source "759 OUT-PZD5 Long".

Overview of the Profibus output data and their assigned sources:

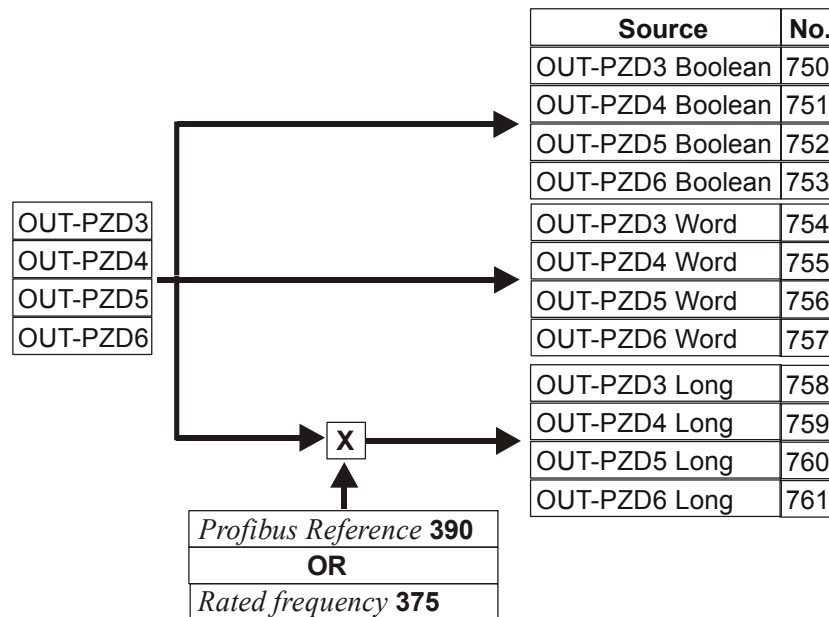

Note: The meaning of the content of the OUT-PZDx data and sources is based on the use in question. If, for example, Boolean variables are to be used, the corresponding entries TRUE/FALSE in the OUT-PZDx objects are to be done on the PLC side. On the device side, only the assigned Boolean sources (750 - 753) are then relevant. The Word and Long sources then do not contain any sensible data.

Any combinations of Boolean, Word and Long can be used. Only pay attention to the assignment of the output objects in the PLC and the assigned sources.

Examples STEP7-Program:

```
// OUT_PZDx are symbols for the equivalent peripheral addresses

// Boolean

      U      E      1.0
      FP     M      1.0
      SPBN   BC1           // no pos. edge
      L      L#65535      // pos. edge
      T      OUT_PZD3     // store TRUE to OUT-PZD3 Boolean

BC1:  U      E      1.0
      FN     M      1.1
      SPBN   BC2           // no neg. edge
      L      0             // neg. edge
      T      OUT_PZD3     // store FALSE to OUT-PZD3 Boolean

BC2:  ...

// Percent

      L      "AnalogIn2"  // load analogue-input 2
      SRW    7            // scale to 0...100,00 = 0 ... 10000
      L      49
      *I
      T      OUT_PZD6     // store value to OUT-PZD6 Word

// Frequency

      L      "AnalogIn1"  // load analogue-input1
      SRW    7            // scale to Profidrive notation !!!
      L      90
      *I
      T      OUT-PZD4 Long // store value to OUT-PZD4 Long
```

10.3 Actual value display of Profibus data

For analysis purposes, *DP-Master OUT 281* and *DP-Master IN 284* are displayed in the data transmitted via the Profibus under the actual value parameters.

The parameters are in the "**Actual values \ Actual values frequency inverter**" menu point of the VPlus program and can only be looked at with the latter.

In these parameters, the data transmitted via the Profibus are displayed in a processed and comprehensible form. The contents of the process data channel with control word, reference value etc. are permanently updated. As the communication channel has the contents zero in idling and transmission is very quick, the contents of the communication channel are stored on the device side and displayed in the actual value parameters with every transmission.

The displayed content of the communication channel accordingly do not correspond to the current state, but the last transmission.

Note: The use of the VPlus program with simultaneous use of the Profibus-DP communication module CM-PDP is only possible with the KP232 serial adapter on the slot of the KP500 control unit.

The following diagram shows the display for an object of type PPO2. The contents also apply for the other objects, PPO1, PPO3 and PPO4. In these objects, a part quantity is displayed each time.

Actual value

Parameter *DP-Master OUT 281* = PKE: a nnn IND: ii 00 PWE: wwwwww CTR: cccc STP: ssss 3: xxxx 4: xxxx 5: xxxx 6: xxxx

Meaning			
PKE: a	a	= order identification	hexadecimal
PKE: nnn	nnn	= parameter number	decimal
IND: ii	ii	= index	hexadecimal
PWE: ww..w	ww..w	= parameter value	decimal (with sign in front)
CTR: cccc	cccc	= control word	hexadecimal
STP: ssss	ssss	= reference value	hexadecimal, relative to 0x4000 = 100% of the reference value
3: xxxx	xxxx	= 0000	not used
4: xxxx	xxxx	= 0000	not used
5: xxxx	xxxx	= 0000	not used
6: xxxx	xxxx	= 0000	not used

Actual value

Parameter *DP-Master IN 284* = PKE: a nnn IND: ii 00 PWE: wwwwww STA: cccc VAL: ssss 3: xxxx 4: xxxx 5: xxxx 6: xxxx

Meaning			
PKE: a	a	= reply identification	hexadecimal
PKE: nnn	nnn	= parameter number	decimal
IND: ii	ii	= index	hexadecimal
PWE: ww..w	ww..w	= parameter value	decimal (with sign in front)
STA: cccc	cccc	= state word	hexadecimal
VAL: ssss	ssss	= actual value	hexadecimal, relative to 0x4000 = 100% of the reference value
3: xxxx	xxxx	= abs. current	hexadecimal, relative to 0x4000 = 100% of the rated motor current
4: xxxx	xxxx	= active current	hexadecimal, relative to 0x4000 = 100% of the rated motor current
5: xxxx	xxxx	= Warning	hexadecimal (bit-coded)
6: xxxx	xxxx	= Fault	hexadecimal

Example:

Actual value

Parameter DP-Master OUT 281 = PKE: 6 480 IND: 03 00 PWE: -005500 CTR: 000F STP: 2000 3: 0000 4: 0000 5: 0000 6: 0000

Meaning

PKE: 6	Order identification = 6 (Read parameter value Array)
PKE: 480	Parameter number = 480 (Fixed frequency 1)
IND: 03 00	Data set = 3
PWE: -005500	Parameter value = -5500 = -55.00 Hz (0xFFFEA84 hexadecimal)
CTR: 000F	Release command (transition 4)
STP: 2000	Set point = 0x2000 = 50% of the reference value
3: 0000	not used
4: 0000	not used
5: 0000	not used
6: 0000	not used

Actual value

Parameter DP-Master IN 284 = PKE: 5 480 IND: 03 00 PWE: -005500 STA: 06A7 VAL: 2000 3: 1147 4: 0CCC 5: 0800 6: 0000

Meaning

PKE: 5	Reply identification = 5 (Transmit parameter value long Array)
PKE: 480	Parameter number = 480 (Fixed frequency 1)
IND: 03 00	Data set = 3
PWE: -005500	Parameter value = -5500 = -55.00 Hz (0xFFFEA84 hexadecimal)
STA: 06A7	State = 0x27 "Operation enabled" (Bit 0 ... 6), Warning 2 available (Bit 15 = 1 threat of fault switch-off), reference value reached (Bit 10 = 1), remote operation (Bit 9 = 1), Warning available (Bit 7 = 1)
VAL: 2000	Actual value = 0x2000 = 50% of the reference value
3: 1147	Abs. current = 0x1147 = 27% of the rated motor current
4: 0CCC	Active current = 0x0CCC = 20% of the rated motor current
5: 0800	Warning, Warning motor temperature available
6: 0000	Fault, no fault available

11 Parameter list

The parameter list is structured according to the menu branches of the operating unit. For better clarity, the parameters have been marked with pictograms:





-  The parameter is available in the four data sets
- The parameter value is set by the SET-UP routine
- This parameter cannot be written in the operation of the frequency inverter.

11.1 Actual value

Actual values of the frequency inverter				
No.	Description	Unit	Display range	Chapter
228	Internal reference frequency	Hz	-1000,00 to 1000,00	10.2.5
249	Active data set	-	1 to 4	10.2.1
250	Digital inputs	-	0 to 255	10.2.4
270	Warnings	-	0 to 0xFFFF	12.1
281	DP-Master OUT	-	String	10.3
282	Reference bus frequency	Hz	-1000.00 to 1000.00	10.2.5
283	Reference ramp frequency	Hz	-1000.00 to 1000.00	10.2.5
284	DP-Master IN	-	String	10.3

Note: The parameters *DP Master OUT* **281** and *DP Master IN* **284** can only be displayed via the VPlus program. Operation of the VPlus program in use of the Profibus-DP communication module CM-PDP is only possible via the optional KP232 serial adapter on the slot of the KP500 control unit. The parameter *Warnings* **270** is only accessible via the communication channel of objects PPO1 and PPO2. It cannot be addressed via the VPlus program or the KP500 control unit.

11.2 Parameter

Rated motor parameters				
No.	Description	Unit	Setting range	Chapter
	375 Rated frequency	Hz	10.00 to 1000.00	10.2.5
Profibus				
390	Profibus Reference	Hz	0.00 to 999.99	10.2.5
391	Profibus Node-ID	-	0 to 126	6
Bus control				
392	State-transition 5	-	0 to 2	10.2.3.2
412	Local/Remote	-	0 to 44	10.2.1
Data set change-over				
414	Data set selection	-	0 to 4	10.2.1
Frequency ramps				
	424 Emergency stop clockwise	Hz/s	0.01 to 9999.99	10.2.3.1
	425 Emergency stop anticlockwise	Hz/s	0.01 to 9999.99	10.2.3.1
Frequency ramps				
434	Ramp set point	-	1 to 3	10.2.5
Digital outputs				
549	max. Control deviation	%	0.01 to 20.00	10.2.2
Stopping behavior				
	637 Switch-off threshold	%	0.0 to 100.0	10.2.3.1
	638 Holding time"	s	0.0 to 200.0	10.2.3.1

Note: The parameter *Data set selection* **414** is only accessible via the communication channel of objects PPO1 and PPO2. It cannot be addressed via the VPlus program or the KP500 control unit.

12 Annex

12.1 Warning messages

The various control functions and methods and the hardware of the frequency inverter contain functions that continuously monitor the application. In addition ones to the messages documented in the manual the following fault messages are activated by the Profibus-DP communication module CM-PDP.

The warning reports are given via the parameter *Warnings* **270** bit-coded according to the following scheme.

Warning messages		
Bit no.	Warning code	Meaning
0	0x0001	Warning lxt
1	0x0002	Warning Short Term - lxt
2	0x0004	Warning Long Term - lxt
3	0x0008	Warning Heat sink Temperature Tc
4	0x0010	Warning Inside Temperature Ti
5	0x0020	Warning Limit
6	0x0040	Warning Init
7	0x0080	Warning Motor Temperature
8	0x0100	Warning Mains Failure
9	0x0200	Warning Motor Protective Switch
10	0x0400	Warning Fmax
11	0x0800	Warning Analog Input MF11A
12	0x1000	Warning Analog Input A2
13	0x2000	Warning System bus
14	0x4000	Warning Udc
15	0x8000	Warning V-Belt

Note: The meaning of the individual warnings are described in detail in the operating instructions.

12.2 Fault messages

The fault code that is stored after an fault occurs is made up of fault group FXX (high Byte, hexadecimal) and the following code number XX (low Byte, hexadecimal).

Communication fault		
Code	Meaning	
F20	61	Failure Profibus module
	62	Profibus OFF (failure DP Master)
	65	Profibus configuration fault

Alongside the fault messages stated, there are further fault messages, however they are only used for internal purposes and are not listed here. If you receive fault messages which are not listed here, please contact us by phone.

12.3 GSD File – VEC_0696.GSD

```

;=====
; Profibus Device Database of :
;   HMS Industrial Networks AB DP slave
;   Model : ANYBUS-IC PDP
;   Description : ANYBUS-IC Profibus DP slave
;   Language : English
;   Date : 12 September 2001
;   Author : HMS Industrial Networks AB, Vectron Elektronik GmbH
;=====
#Profibus_DP

GSD_Revision          = 2

; Device identification
Vendor_Name          = "HMS Industrial Networks AB"
Model_Name           = "ACT 10"
Revision             = "Version 1.00"
Ident_Number        = 0x0696
Protocol_Ident      = 0                ; DP protocol
Station_Type        = 0                ; Slave device
FMS_supp            = 0                ; FMS not supported
Hardware_Release    = "Version 1.02"
Software_Release    = "Version 1.00"

; Supported baudrates
9.6_supp            = 1
19.2_supp           = 1
45.45_supp          = 1
93.75_supp          = 1
187.5_supp          = 1
500_supp            = 1
1.5M_supp           = 1
3M_supp             = 1
6M_supp             = 1
12M_supp            = 1

; Maximum responder time for supported baudrates
MaxTsd_r_9.6        = 60
MaxTsd_r_19.2       = 60
MaxTsd_r_45.45      = 250
MaxTsd_r_93.75      = 60
MaxTsd_r_187.5     = 60
MaxTsd_r_500        = 100
MaxTsd_r_1.5M       = 150
MaxTsd_r_3M         = 250
MaxTsd_r_6M         = 450
MaxTsd_r_12M        = 800

; Supported hardware features
Redundancy          = 0                ; not supported
Repeater_Ctrl_Sig  = 2                ; TTL
24V_Pins            = 0                ; not connected
Implementation_Type = "SPC3"

```

```
; Supported DP features
Freeze_Mode_supp    = 1          ; supported
Sync_Mode_supp     = 1          ; supported
Auto_Baud_supp     = 1          ; supported
Set_Slave_Add_supp = 1          ; supported

; Maximum polling frequency
Min_Slave_Intervall = 1          ; 100 us

; Maximum supported sizes
Modular_Station    = 1          ; modular
Max_Module         = 24
Max_Input_Len      = 48
Max_Output_Len     = 48
Max_Data_Len       = 96
Modul_Offset       = 1

Fail_Safe          = 1          ; state CLEAR accepted

Slave_Family       = 1          ; Drives
Max_Diag_Data_Len = 6

; UserPrmData: Length and Preset
Max_User_Prm_Data_len = 16
Ext_User_Prm_Data_Const(0) = 0x00
Ext_User_Prm_Data_Const(1) = 0x00
Ext_User_Prm_Data_Const(2) = 0x00
Ext_User_Prm_Data_Const(3) = 0x00
Ext_User_Prm_Data_Const(4) = 0x00
Ext_User_Prm_Data_Const(5) = 0x00
Ext_User_Prm_Data_Const(6) = 0x00
Ext_User_Prm_Data_Const(7) = 0x00
Ext_User_Prm_Data_Const(8) = 0x00
Ext_User_Prm_Data_Const(9) = 0x00
Ext_User_Prm_Data_Const(10) = 0x00
Ext_User_Prm_Data_Const(11) = 0x00
Ext_User_Prm_Data_Const(12) = 0x00
Ext_User_Prm_Data_Const(13) = 0x00
Ext_User_Prm_Data_Const(14) = 0x00
Ext_User_Prm_Data_Const(15) = 0x00

; Definition of modules
Module = "PPO1: 4 Words PKW, 2 Words PZD" 0xF3 , 0x71
EndModule
;
Module = "PPO2: 4 Words PKW, 6 Words PZD" 0xF3 , 0x75
EndModule
;
Module = "PPO3: 2 Words PZD" 0x71
EndModule
;
Module = "PPO4: 6 Words PZD" 0x75
EndModule
```



VECTRON

VECTRON Elektronik GmbH
Europark Fichtenhain A6
D-47807 Krefeld
Phone : +49 (0) 2151 / 83 96 0
Fax : +49 (0) 2151 / 83 96 99
Service: +49 (0) 2151 / 83 96 66
Internet : www.VECTRON.net

The reproduction, transmission or use of this document, or its contents is not permitted unless authorized in writing by VECTRON Elektronik GmbH, D-47807 Krefeld.