



Latches with handle and rod control for cabinets

- **Glass-fibre reinforced polyamide-based (PA) technopolymer handle.** Resistant to solvents, oils, greases and other chemical agents.
- **Black** standard colour with matte finish.
- Nickel-plated zama alloy **support base**.
- CL+C latches are available in two different executions:
 - **with plug for protection IP65** (see page 385) **and sealing washer** (type CL/IP).
 - **standard version without protecting plug.**
- Black oxide steel **handle pin** with NBR rubber **O-ring**.
- Chromate treated zinc-alloy **rod control**.
- Glossy galvanised steel **connecting rods**.
- **Two NBR sealing washers** for the support plate.
- **European style stator:**
 - lock with different numbers (type CL.)
 - lock with same numbering (type CLU.)
 - with two-wing key mark (type CLA.)
- Two nickel-plated brass **keys** for locks with code, removable in two positions at 180°, or with technopolymer key with zama insert for a lock with two-wing mark.

Accessories on request:

- 1 pair of rod guides in black technopolymer (1 rod guide every 500 mm of rod length)
- 1 pair of glossy flat galvanised steel rods, cross-section 14x3 mm, length 1.000 mm. Technopolymer edge rollers (version for frame thickness of 20 or 25 mm).

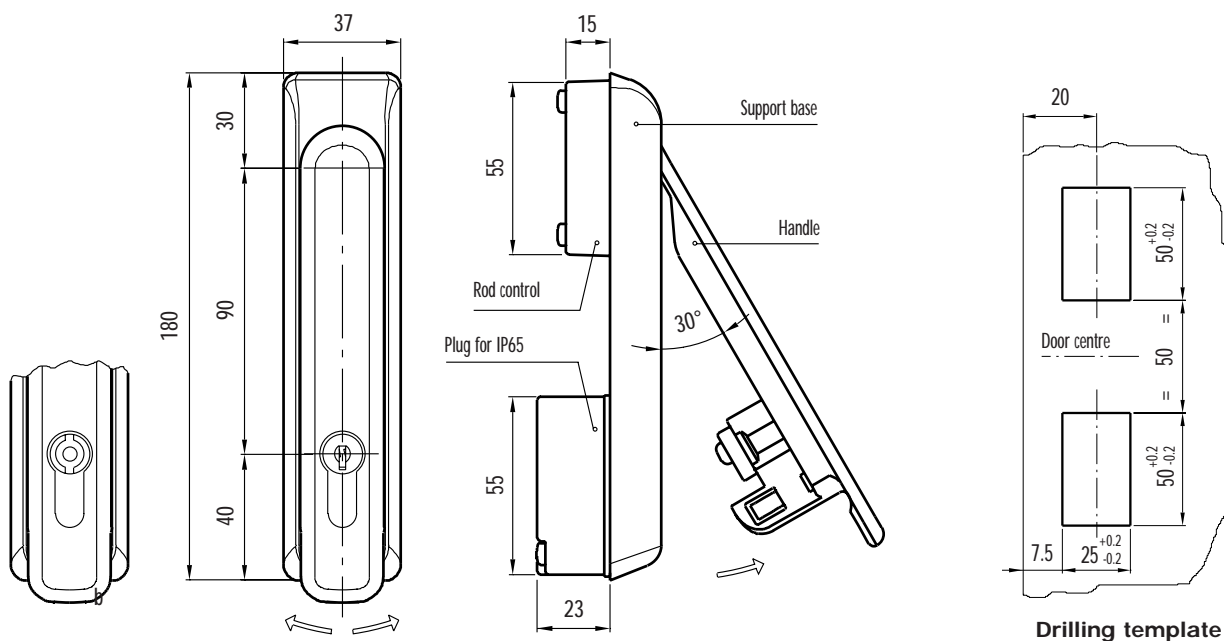

Standard elements		Weight
Code	Description	grams
421111	CL.160+C	418
421113	CLU.160+C	418
421115	CLA.160+C	416
421121	CL.160/IP+C	430
421123	CLU.160/IP+C	430
421125	CLA.160/IP+C	428