

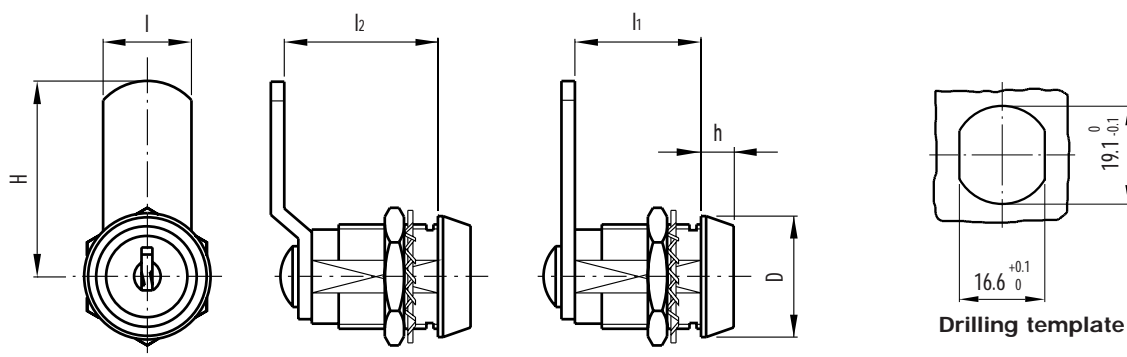

Latches with lock

- Brass-plated zinc alloy **rotor and stator**, stainless steel front plate.
- Assembly with **brass nut** M19x1 and galvanised steel spring washer.
- **180° rotation.**
- Two nickel-plated **brass keys**, removable in two positions at 180°.
- Galvanised and tropicalised steel **closing lever**, 2.5 mm thickness. Lever assembly with hex nut (l1 = 13 and 16 mm), with screw M5x5 (l1 = 20 mm) or with screw M5x8 (l1 = 25 and 30 mm). Levers with other dimensions on request and for sufficient quantities.
- **Version CS.** lock with different numbers (400 different combinations).
- **Version CSU.** lock with same numbering.

Galvanised steel threaded extension for lever advanced positioning on request (only for stator lengths of 20, 25 and 30 mm).



Standard elements		Main dimensions						Weight
Code	Description	D	h	l	l1	l2	H	grams
421411	CS.13/32				13			41
421413	CS.16/32				16			47
421415	CS.20/32	23	5	16	20	-	32	55
421417	CS.25/32				25			64
421419	CS.30/32				30			73
421431	CS.13/36-18				13	18		43
421433	CS.16/36-21				16	21		49
421435	CS.20/36-25	23	5	16	20	25	35.5	57
421437	CS.25/36-30				25	30		66
421439	CS.30/36-35				30	35		75
421451	CSU.13/32				13			41
421453	CSU.16/32				16			47
421455	CSU.20/32	23	5	16	20	-	32	55
421457	CSU.25/32				25			64
421459	CSU.30/32				30			73
421471	CSU.13/36-18				13	18		43
421473	CSU.16/36-21				16	21		49
421475	CSU.20/36-25	23	5	16	20	25	35.5	57
421477	CSU.25/36-30				25	30		66
421479	CSU.30/36-35				30	35		75