

ELESA Original design

Adjustable handles



• Lever body

Zinc alloy die-cast, epoxy resin coating.

• Colour

RAL 2004 orange, RAL 3000 red, RAL 9006 grey, RAL 9005 black matte finish.

• Clamping element

AISI 303 stainless steel with threaded bore and toothed element for coupling to the lever body, stainless steel retaining screw and return spring.

Special executions on request (For sufficient quantities)

- Lever body in different colours.
- Chrome-plated lever.
- Clamping element with plain hole.

Features and applications

Particularly suitable when the lever turning angle is limited owing to lack of space.

AISI 303 stainless steel, thanks to its high resistance to corrosion, allows the application of these adjustable handles on machines and equipment in those sectors where laws or particular hygienic, climatic and environmental factors make it mandatory to use corrosion resistant materials.

Instructions of use

For clamping, lift the lever to disengage the clamping device toothing and bring it back to start position. By releasing the lever, the return spring automatically engages the toothing.

If the lever cannot make a 360° rotation, the clamping element can be easily screwed by means of the hexagon socket front head screw (after having disengaged the lever).

Ergonomy and design

The slightly arched shape of the lever and the ergonomic terminal enlargement give the operator a comfortable and safe grip and make the design of the handle more elegant.

The design of the lever body of this series is exactly like the design of ERX.SST adjustable levers, which has been awarded by the following juries for Industrial Design: Die Gute Industrieform Hannover 1995, Internationaler Designpreis des Landes Baden-Württemberg 1996/97.

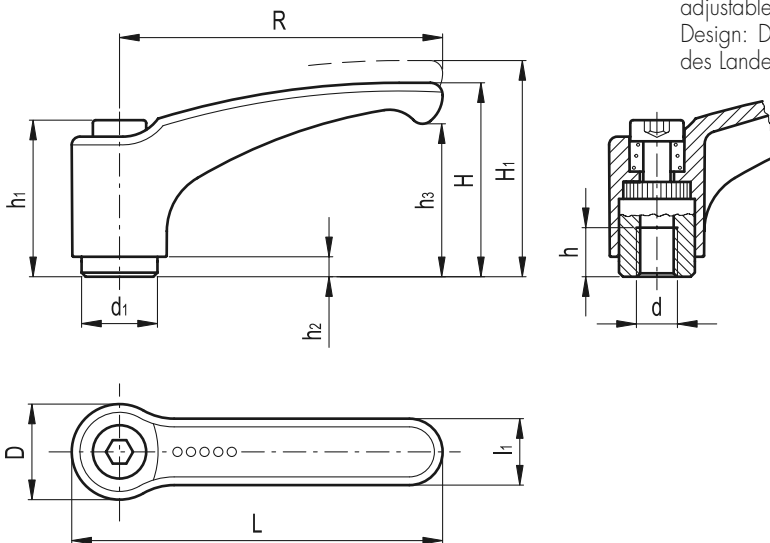

C2 RAL 2004 **C6** RAL 3000 **C8** RAL 9006 **C9** RAL 9005

Standard Elements		Main dimensions										Mounting hole		Teeth no.	Δ
Code	Description	R	L	D	H	H ₁	h ₁	h ₂	h ₃	d ₁	l ₁	d	h	z	g
241002-*	ERM.44 SST-A-M4-*	44	52	14.5	30	33	24.5	3.5	20.5	10	11	M4	8	18	16
241003-*	ERM.44 SST-A-M5-*	44	52	14.5	30	33	24.5	3.5	20.5	10	11	M5	8	18	15
241014-*	ERM.63 SST-A-M6-*	63	73.5	18	38	41	31	3.5	27	13.5	13.5	M6	10	24	36
241015-*	ERM.63 SST-A-M8-*	63	73.5	18	38	41	31	3.5	27	13.5	13.5	M8	10	24	34
241025-*	ERM.78 SST-A-M8-*	78	90.5	21.5	46	50	36	3.5	34.5	16	16	M8	14	26	61
241026-*	ERM.78 SST-A-M10-*	78	90.5	21.5	46	50	36	3.5	34.5	16	16	M10	14	26	55
241036-*	ERM.95 SST-A-M10-*	95	109	25	56	61	43	5	42	19.5	18	M10	17	28	93
241037-*	ERM.95 SST-A-M12-*	95	109	25	56	61	43	5	42	19.5	18	M12	17	28	86

* Complete the code and the description of the standard item needed by adding the index of the colour of the lever body (C2,C6,C8,C9), ex: 241002-C2 ERM.44 SST-A-M4-C2