

Solid handwheels

- **Glass-fibre reinforced polyamide based (PA) technopolymer.**
Resistant to solvents, oils, greases and other chemical agents.
- **Black** standard colour with matte finish.
- Black oxide **steel boss** with standard H7 tolerance reamed hole.
- Acetal resin based (POM) black technopolymer press-fit **boss cap** removable by pressing on the out side edge.
- Matte anodised **aluminium ring** (ELESA original design).
- **Rear finger grips.**
- **Axial retaining washer** (on request) type GN 184 (page 452).

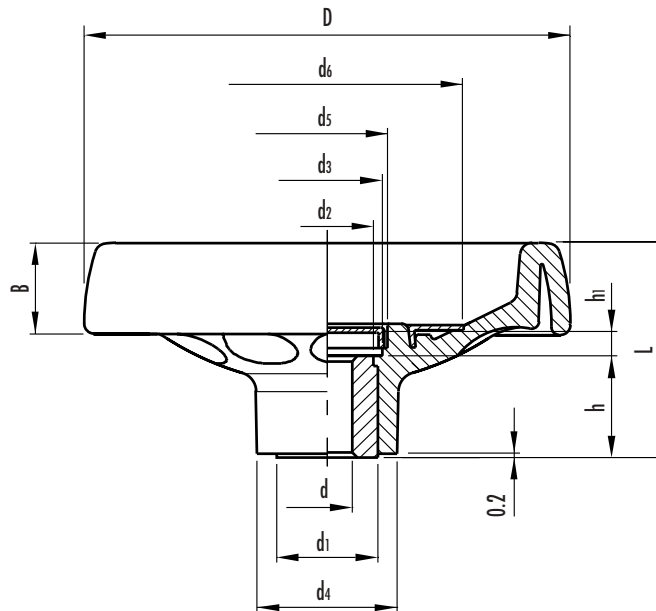

This product has been selected for its design by the international jury of "Die gute Industrieform-Hannover 2003"



See Technical Data for maximum applicable torque (C) and impact strength (L).

Standard elements		Main dimensions										Bore		C	L	Weight
Code	Description	D	L	B	d1	d2	d3	d4	d5	d6	h1	d H7	h	[N·m]	[J]	grams
170307	VDT.100 A-10	100	49	22	22	20	26	32	28	54	5.5	10	22	180	21	155
170505	VDT.125 A-12	125	57	24	26	24	28	36	31	70	7	12	27	200	23	285
170707	VDT.160 A-14	160	64	27	35	33	38	46	40	90	11	14	28	400	25	505
170907	VDT.200 A-20	200	68	30	40	36	50	51	52	110	9	20	31	600	35	730