

MP

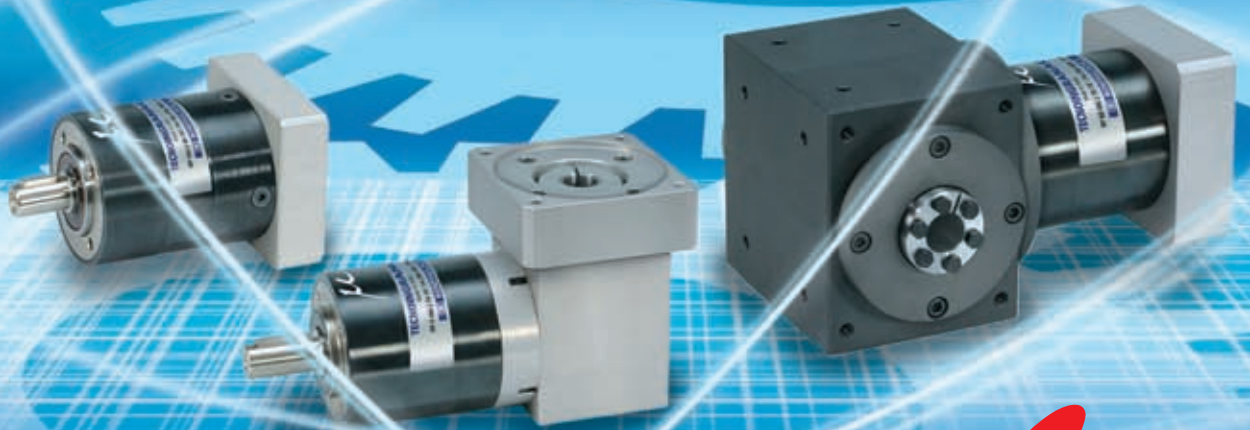

BONFIGLIOLI

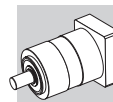

SUMMARY

Chapter Contents



1	General information	2
1.1	Symbols and units of measurement	2
1.2	Features of MP series	3
1.3	Versions	4
1.4	Selecting the gear unit	5
1.5	Service life of bearings	6
1.6	Ordering code	8
2	Gearbox rating chart	9
2.1	MP 053	9
2.2	MP 060	10
2.3	MP 080	11
2.4	MP 105	12
2.5	MP 130	13
2.6	MP 160	14
2.7	MP 190	15
2.8	Permitted axial and radial forces for version MP..MB	16
2.9	Mass moment of inertia	17
2.9.1	MP 053	17
2.9.2	MP 060	18
2.9.3	MP 080	19
2.9.4	MP 105	20
2.9.5	MP 130	21
2.9.6	MP 160	22
2.9.7	MP 190	23
3	Dimensions	24
3.1	MP 053	24
3.2	MP 060	25
3.3	MP 080	26
3.4	MP 105	28
3.5	MP 130	30
3.6	MP 160	32
3.7	MP 190	34
3.8	Gearbox without motor adapter	35

Revisions

Refer to page 36 for the catalogue revision index.

Visit www.tecnoingranaggi.it to search for catalogues with up-to-date revisions.

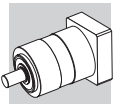

1 GENERAL INFORMATION

1.1 SYMBOLS AND UNITS OF MEASUREMENT

A_n	[N]	The admissible thrust force can be applied axially to the shaft under study along. The catalogue value is calculated for an output speed $n_2 = 100 \text{ min}^{-1}$
C_t	[Nm/arcmin]	Torsional stiffness
		Gear ratio is expressed as the relationship of the input speed to the output speed:
i	-	$i = \frac{n_1}{n_2}$
I	-	Intermittence is defined as the relationship of the operating time to the cycle time
f_c	-	Cycle factor. An adjusting factor that is to be accounted for when selecting gear unit operating under continuous duty S1
f_z	-	Service factor
M_{a2}	[Nm]	Maximum acceleration torque acceptable for a duty with $I < 60\%$
M_{n2}	[Nm]	Nominal output torque
M_{p2}	[Nm]	Emergency stop torque. The value cannot apply more than 1000 times over the entire life of the gear unit and should not recur in normal operating conditions
J	[Kgc m^2]	Mass moment of inertia of the gear unit
L_{10}	[h]	Average service life of bearings
n_1	[min^{-1}]	Nominal input speed (continuous duty S1). It is the reference speed for duties with intermittence $I \geq 60\%$ and/or operating time $\geq 20 \text{ min}$
$n_{1\text{max}}$	[min^{-1}]	Maximum momentary input speed. The speed the unit can be driven at occasionally and in non-repetitive conditions. For cyclic duty, type S5, it cannot be applied continuously for more than 30 seconds
R_n	[N]	The admissible radial force must be equal to, or greater than, the radial force actually applying onto the shaft. Catalogue value is based on output speed $n_2 = 100 \text{ min}^{-1}$
T_c	[$^{\circ}\text{C}$]	Housing temperature. Under no circumstances it should exceed 90°C
φ_s	[arcmin]	Standard backlash is calculated in static conditions and with the application of a torque equal to 2% of the nominal torque for the gear unit
φ_R	[arcmin]	Reduced backlash is calculated in static conditions and with the application of a torque equal to 2% of the nominal torque for the gear unit
		Dynamic efficiency is calculated through the relationship of output torque to torque applied to input shaft under nominal conditions:
η	[%]	$\eta_d = \frac{M_2}{M_1 \times i} \times 100$
Z	-	Number of accelerations/switches per hour

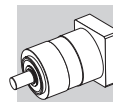

1.2 FEATURES OF MP SERIES

- Available in either standard or reduced backlash
- Bearings are rated for an average service life of 20,000 hours under nominal operating conditions. As standard, frame sizes 053, 060, 080 and 105 feature rigid ball bearings while sizes 130, 160 and 190 feature taper roller bearings. On request, taper roller bearings can be supplied on units 080 and 105 specifying option **CR**
- The gearbox is filled in the factory with a lubricant suitable for ambient temperatures in the 0°C to 40°C range. Because the quantity of lubricant required depends on the mounting position, this must be specified in the order. The lubricant does not normally require changing unless it becomes contaminated from outside. The type of lubricant used (grease or synthetic oil) and the material used for the seals also vary according to duty rating and gearbox size. The chart below illustrates the various combinations:

duty	053	060	080	105	130	160	190
S1	G / V	G / V	O / V	O / V	O / V	O / V	O / V
S5	G / NBR	G / NBR	G / NBR	G / NBR	G / NBR	G / NBR	G / NBR

Legend:

S1 = Continuous duty

S5 = Intermittent duty

O = Synthetic oil, viscosity ISO VG 220

G = Grease, consistency 00

V = Viton® seals

NBR = Nitrile rubber seals

- Degree of protection IP65
- Noise level $L_p \leq 70$ dB(A) - $n_1 = 3000$ min⁻¹
- Numerous input options
- Ratio $i = 10$ available for single-reduction units ($i=9$ for frame size 053 alone)

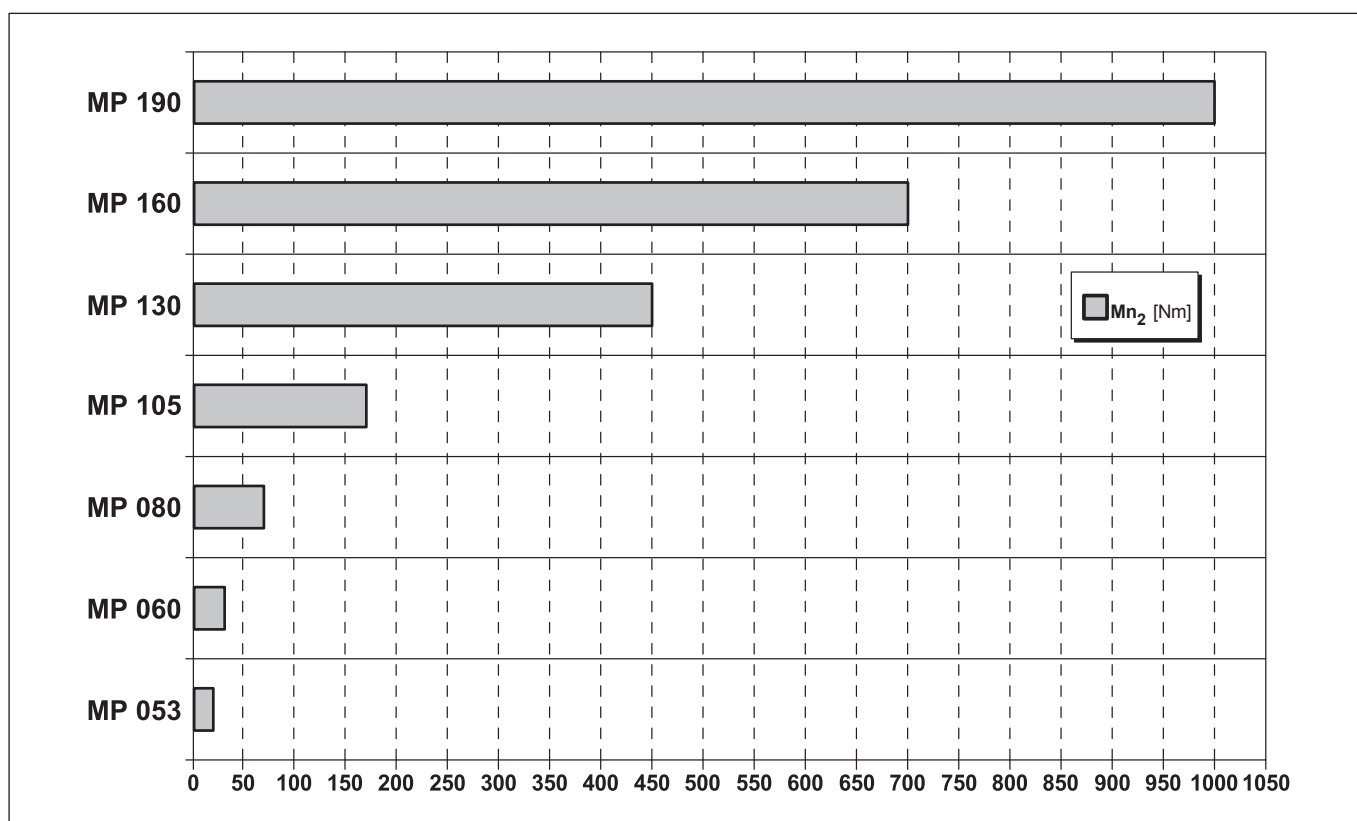

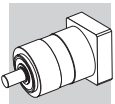

1.3 VERSIONS

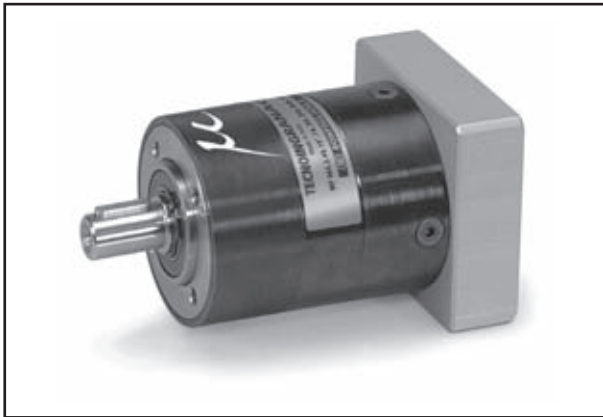

—

Coaxial gear unit

053...190

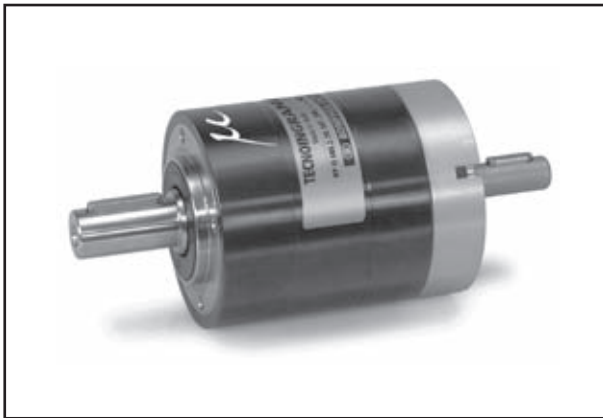

IS

Gear unit with solid input shaft

053...160

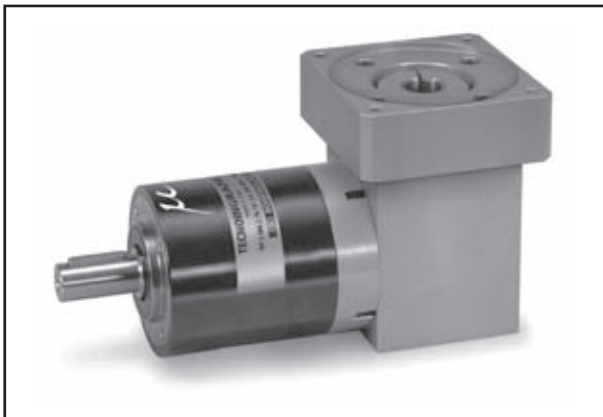

G

Right-angle gear unit

053...160

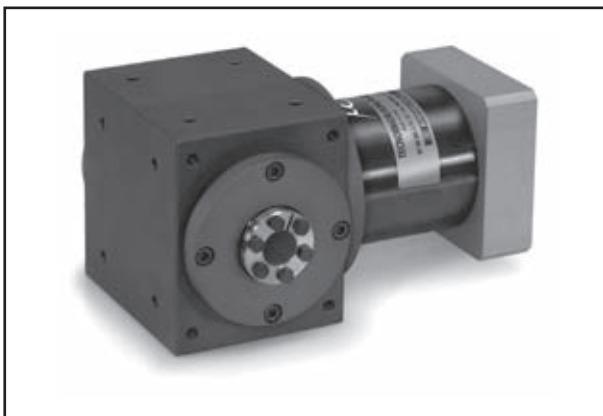

MB

Right angle gear unit with through hollow shaft

080...160

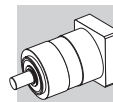

1.4 SELECTING THE GEAR UNIT

- Determine intermittence I:

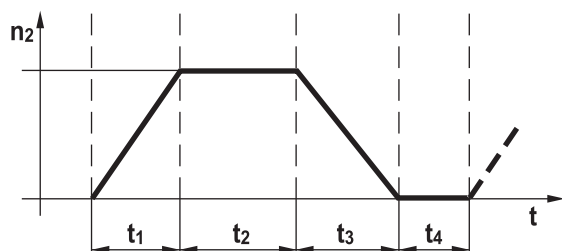

$$I [\%] = \frac{t_1 + t_2 + t_3}{t_1 + t_2 + t_3 + t_4}$$

- t_1 = starting time
- t_2 = operating time at constant speed
- t_3 = stopping time
- t_4 = rest time

- 1) Determine the applicable duty for the application:

	Z ≤ 1000	Z > 1000
I < 60%	S5	S1
I ≥ 60%	S1	S1

S5 cyclic duty

- 2) Search the gear unit for which the condition is verified:

$$M_{a2} \geq M_{1max} \times i \times \eta$$

M_{1max} = Maximum acceleration torque of motor

S1 continuous duty

- 2) Determine service factor f_z :

Z	f_z
Z ≤ 1000	1.00
1000 < Z ≤ 1500	1.25
1500 < Z ≤ 2000	1.50
2000 < Z ≤ 2500	1.75
2500 < Z ≤ 3000	2.00
Z > 3000	Contact us

- 3) Determine cycle factor f_c :

I	20%...60%	80%	100%
f_c	1.0	1.2	1.4

- 4) Search the gear unit for which the condition is verified:

$$M_{n2} \geq M_{1max} \times i \times \eta \times f_z \times f_c$$



If, under particular operating conditions, a housing temperature higher than usual is to be expected, it is recommended that Viton® seals are specified at the time of order through option **S1**. Under no circumstances the maximum speed [n_{1max}] permitted for the gear unit should be exceeded. Should the surface temperature exceed 90°C it is recommended that speed is reduced, or an auxiliary cooling system is provided.

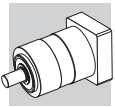

1.5 SERVICE LIFE OF BEARINGS

Whether bearings are ball type (**CS**) or taper roller type (**CR**), their service life can be calculated through the equations where actual radial and axial forces are accounted for.

MP 053	MP 060	MP 080	MP 105	MP 130	MP 160	MP 190
CS	CS	CS(*)	CS(*)	CR	CR	CR

(*) Option **CR** available

	A_2 [N]	Offset axial force
	R_2 [N]	Radial force
	D_a [mm]	Distance of axial force from shaft centre
	D_r [mm]	Distance of radial force from mounting flange

SERVICE LIFE CALCULATION FOR RIGID BALL BEARINGS (CS)

$$F_{eq} = \frac{A_2 \times D_a + R_2 \times (D_r + b)}{a}$$

$$n_a = \frac{n_1 \times t_1 + n_2 \times t_2 + \dots + n_5 \times t_5}{t_1 + t_2 + t_3 + t_4 + t_5 + t_6}$$

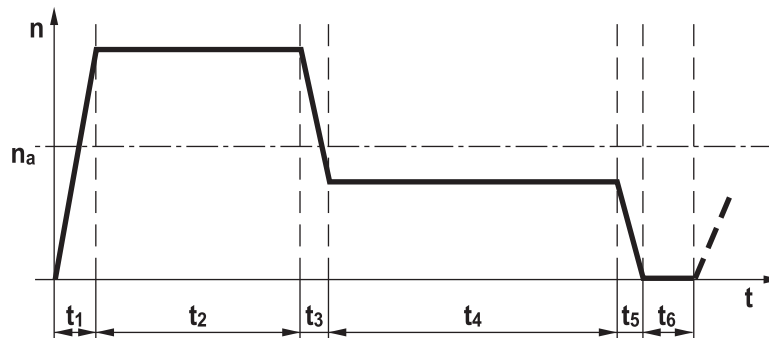

$$L_{10}(h) = \frac{16666}{n_a} \times \left(\frac{c}{F_{eq}} \right)^3$$

Load location factor	MP 053	MP 060	MP 080	MP 105
a	15.5	14.4	21.5	24.5
b	17	17.4	32.3	36
c	5600	9550	14000	25700

F_{eq} [N] = Equivalent force resulting from radial and axial forces applying simultaneously

n_a [min⁻¹] = Mean output speed

$L_{10}(h)$ = Theoretical service life of bearings

Calculate $e = A_2/F_{eq}$, and check that condition $e \leq 0.19$ is verified.

If $e > 0.19$ contact our Technical Service.

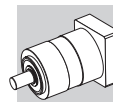

SERVICE LIFE CALCULATION FOR TAPER ROLLER BEARING (CR)

$$F_{eq} = \frac{A_2 \times D_a + R_2 \times (D_r + b)}{a}$$

$$n_a = \frac{n_1 \times t_1 + n_2 \times t_2 + \dots + n_5 \times t_5}{t_1 + t_2 + t_3 + t_4 + t_5 + t_6}$$

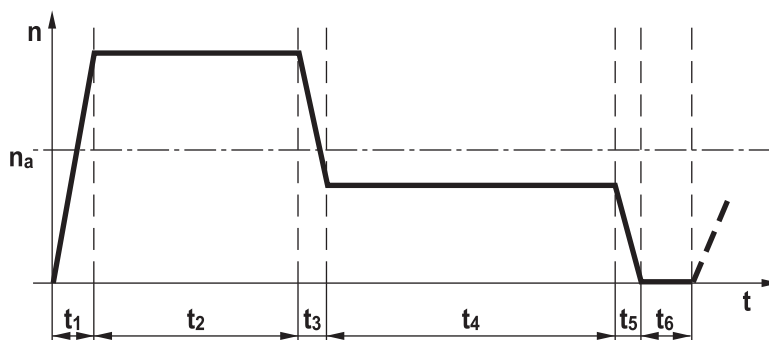

$$L_{10}(h) = \frac{16666}{n_a} \times \left(\frac{c}{F_{eq}} \right)^{10/3}$$

Load location factor	MP 080	MP 105	MP 130	MP 160	MP 190
a	28	35	45	52	62
b	35.55	41.25	51.75	56.75	64.25
c	30800	51200	76500	99000	14000

F_{eq} [N] = Equivalent force resulting from radial and axial forces applying simultaneously

n_a [min⁻¹] = Mean output speed

$L_{10}(h)$ = Theoretical service life of bearings

Calculate $e = A_2/F_{eq}$, and check that condition $e \leq 0.4$ is verified.

If $e > 0.4$ contact our Technical Service.

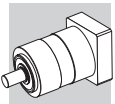

1.6 ORDERING CODE

MP	G	080	2	70	10'	14	30	60	75	CR	S1	O	TH
----	---	-----	---	----	-----	----	----	----	----	----	----	---	----

TH: MOTOR WITH THREADED HOLES

MOUNTING POSITION:
O (horizontal)
VS (vertical - motor up)
VI (vertical - motor down)

S1: continuous duty setting

CR: taper roller bearings

PCD OF MOTOR ADAPTER HOLES

PILOT DIAMETRE OF MOTOR ADAPTER

MOTOR SHAFT LENGTH

MOTOR SHAFT DIAMETER

	MP 053	MP 060	MP 080	MP 105	MP 130	MP 160	MP 190
D	6 - 6.35	6 - 6.35	8 - 9	11 - 12	14 - 15.875	14 - 15.875	14 - 16
	7 - 8	7 - 8	9.52 - 11	12.7 - 14	16 - 19	16 - 19	19 - 22
	9 - 9.52	9 - 9.52	12 - 12.7	15 - 15.875	22 - 24	22 - 24	24 - 28
	10 - 11	10 - 11	14 - 15.875	16 - 19	28 - 32	28 - 32	32 - 35
	12 - 12.7	12 - 12.7	16 - 17	22 - 24	35 - 38	35 - 38	38 - 42
	14	14	19 - 19.05	28 - 32			45 - 48

BACKLASH

	1-stage	2-stages	3-stages
Standard	15'	15'	17'
Reduced	10'	10'	12'

GEAR RATIO

REDUCTIONS
1, 2, 3

FRAME SIZE
053, 060, 080, 105, 130, 160, 190

VERSIONS
— = coaxial
IS = solid input shaft
G = right angle gear unit
MB = right angle gear unit with through hollow shaft

SERIES
MP

Optional variant

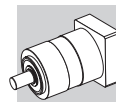

2 GEARBOX RATING CHART

2.1 MP 053

MP 053												
i	M _{n2} [Nm]	M _{a2} [Nm]	M _{p2} [Nm]	n ₁ [min ⁻¹]	n _{1max} [min ⁻¹]	φ _S [arcmin]	φ _R [arcmin]	C _t [Nm/arcmin]	R _{n1} [N]	R _{n2} [N]	A _{n2} [N]	η %
MP 053 1_3	12	22	40	3300	4000	15'	10'	1.0	200	500	600	97
MP 053 1_4	15	28	45	3500	5000	15'	10'	1.0	200	500	600	97
MP 053 1_5	15	28	45	3500	5000	15'	10'	1.0	200	500	600	97
MP 053 1_6	15	28	45	3500	5000	15'	10'	1.0	200	500	600	97
MP 053 1_7	15	28	45	4000	6000	15'	10'	1.0	200	500	600	97
MP 053 1_9	12	22	40	4000	6000	15'	10'	1.0	200	500	600	97
MP 053 2_12	20	30	60	3300	4000	15'	10'	0.9	200	500	600	94
MP 053 2_15	20	30	60	3300	4000	15'	10'	0.9	200	500	600	94
MP 053 2_16	20	30	60	3500	5000	15'	10'	0.9	200	500	600	94
MP 053 2_20	20	30	60	3500	5000	15'	10'	0.9	200	500	600	94
MP 053 2_25	20	30	60	3500	5000	15'	10'	0.9	200	500	600	94
MP 053 2_28	20	30	60	4000	6000	15'	10'	0.9	200	500	600	94
MP 053 2_35	20	30	60	4000	6000	15'	10'	0.9	200	500	600	94
MP 053 2_36	15	28	45	4000	6000	15'	10'	0.9	200	500	600	94
MP 053 2_45	20	30	60	4000	6000	15'	10'	0.9	200	500	600	94
MP 053 3_60	20	30	60	3500	5000	17'	12'	0.7	200	500	600	90
MP 053 2_81	12	22	40	4000	6000	15'	10'	0.9	200	500	600	94
MP 053 3_48	20	30	60	3500	5000	17'	12'	0.7	200	500	600	90
MP 053 3_64	20	30	60	3500	5000	17'	12'	0.7	200	500	600	90
MP 053 3_75	20	30	60	3500	5000	17'	12'	0.7	200	500	600	90
MP 053 3_80	20	30	60	3500	5000	17'	12'	0.7	200	500	600	90
MP 053 3_84	20	30	60	4000	6000	17'	12'	0.7	200	500	600	90
MP 053 3_100	20	30	60	3500	5000	17'	12'	0.7	200	500	600	90
MP 053 3_112	20	30	60	4000	6000	17'	12'	0.7	200	500	600	90
MP 053 3_125	20	30	60	3500	5000	17'	12'	0.7	200	500	600	90
MP 053 3_140	20	30	60	4000	6000	17'	12'	0.7	200	500	600	90
MP 053 3_144	20	30	60	4000	6000	17'	12'	0.7	200	500	600	90
MP 053 3_175	20	30	60	4000	6000	17'	12'	0.7	200	500	600	90
MP 053 3_180	20	30	60	4000	6000	17'	12'	0.7	200	500	600	90
MP 053 3_216	20	30	60	3500	5000	17'	12'	0.7	200	500	600	90
MP 053 3_225	20	30	60	4000	6000	17'	12'	0.7	200	500	600	90
MP 053 3_245	20	30	60	4000	6000	17'	12'	0.7	200	500	600	90
MP 053 3_252	20	30	60	4000	6000	17'	12'	0.7	200	500	600	90
MP 053 3_324	20	30	60	4000	6000	17'	12'	0.7	200	500	600	90
MP 053 3_405	20	30	60	4000	6000	17'	12'	0.7	200	500	600	90
MP 053 3_567	20	30	60	4000	6000	17'	12'	0.7	200	500	600	90
MP 053 3_729	12	22	40	4000	6000	17'	12'	0.7	200	500	600	90

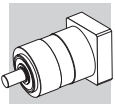

2.2 MP 060

MP 060												
i	M _{n2} [Nm]	M _{a2} [Nm]	M _{p2} [Nm]	n ₁ [min ⁻¹]	n _{1max} [min ⁻¹]	φ _S [arcmin]	φ _R [arcmin]	C _t [Nm/arcmin]	R _{n1} [N]	R _{n2} [N]	A _{n2} [N]	η %
MP 060 1_3	18	35	70	3300	4000	15'	10'	3.0	200	600	700	97
MP 060 1_4	25	40	90	3500	5000	15'	10'	3.0	200	600	700	97
MP 060 1_5	25	40	90	3500	5000	15'	10'	3.0	200	600	700	97
MP 060 1_6	25	40	90	3500	5000	15'	10'	3.0	200	600	700	97
MP 060 1_7	25	40	90	4000	6000	15'	10'	3.0	200	600	700	97
MP 060 1_10	18	35	70	4000	6000	15'	10'	3.0	200	600	700	97
MP 060 2_9	18	35	70	3300	4000	15'	10'	2.5	200	600	700	94
MP 060 2_12	30	45	100	3300	4000	15'	10'	2.5	200	600	700	94
MP 060 2_15	30	45	100	3300	4000	15'	10'	2.5	200	600	700	94
MP 060 2_16	30	45	100	3500	5000	15'	10'	2.5	200	600	700	94
MP 060 2_20	30	45	100	3500	5000	15'	10'	2.5	200	600	700	94
MP 060 2_25	30	45	100	3500	5000	15'	10'	2.5	200	600	700	94
MP 060 2_28	30	45	100	4000	6000	15'	10'	2.5	200	600	700	94
MP 060 2_30	18	35	70	4000	6000	15'	10'	2.5	200	600	700	94
MP 060 2_35	30	45	100	4000	6000	15'	10'	2.5	200	600	700	94
MP 060 2_36	25	40	90	3500	5000	15'	10'	2.5	200	600	700	94
MP 060 2_40	30	45	100	4000	6000	15'	10'	2.5	200	600	700	94
MP 060 2_50	30	45	100	4000	6000	15'	10'	2.5	200	600	700	94
MP 060 2_70	30	45	100	4000	6000	15'	10'	2.5	200	600	700	94
MP 060 2_100	18	35	70	4000	6000	15'	10'	2.5	200	600	700	94
MP 060 3_48	30	45	100	3500	5000	17'	12'	1.8	200	600	700	90
MP 060 3_64	30	45	100	3500	5000	17'	12'	1.8	200	600	700	90
MP 060 3_75	30	45	100	3500	5000	17'	12'	1.8	200	600	700	90
MP 060 3_80	30	45	100	3500	5000	17'	12'	1.8	200	600	700	90
MP 060 3_84	30	45	100	4000	6000	17'	12'	1.8	200	600	700	90
MP 060 3_90	18	35	70	4000	6000	17'	12'	1.8	200	600	700	90
MP 060 3_120	30	45	100	4000	6000	17'	12'	1.8	200	600	700	90
MP 060 3_125	30	45	100	3500	5000	17'	12'	1.8	200	600	700	90
MP 060 3_140	30	45	100	4000	6000	17'	12'	1.8	200	600	700	90
MP 060 3_150	30	45	100	4000	6000	17'	12'	1.8	200	600	700	90
MP 060 3_160	30	45	100	4000	6000	17'	12'	1.8	200	600	700	90
MP 060 3_175	30	45	100	4000	6000	17'	12'	1.8	200	600	700	90
MP 060 3_200	30	45	100	4000	6000	17'	12'	1.8	200	600	700	90
MP 060 3_210	30	45	100	4000	6000	17'	12'	1.8	200	600	700	90
MP 060 3_216	30	45	100	3500	5000	17'	12'	1.8	200	600	700	90
MP 060 3_250	30	45	100	4000	6000	17'	12'	1.8	200	600	700	90
MP 060 3_280	30	45	100	4000	6000	17'	12'	1.8	200	600	700	90
MP 060 3_350	30	45	100	4000	6000	17'	12'	1.8	200	600	700	90
MP 060 3_400	30	45	100	4000	6000	17'	12'	1.8	200	600	700	90
MP 060 3_500	30	45	100	4000	6000	17'	12'	1.8	200	600	700	90
MP 060 3_700	30	45	100	4000	6000	17'	12'	1.8	200	600	700	90
MP 060 3_1000	18	35	70	4000	6000	17'	12'	1.8	200	600	700	90

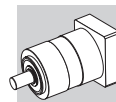

2.3 MP 080

MP 080												
i	M _{n2} [Nm]	M _{a2} [Nm]	M _{p2} [Nm]	n ₁ [min ⁻¹]	n _{1max} [min ⁻¹]	φ _S [arcmin]	φ _R [arcmin]	C _t [Nm/arcmin]	R _{n1} [N]	R _{n2} [N]	A _{n2} [N]	η %
MP 080 1_3	40	80	180	2900	3500	15'	10'	7.0	400	1300	1400	97
MP 080 1_4	50	80	200	3100	4500	15'	10'	7.0	400	1300	1400	97
MP 080 1_5	50	80	200	3200	4500	15'	10'	7.0	400	1300	1400	97
MP 080 1_6	50	80	200	3200	4500	15'	10'	7.0	400	1300	1400	97
MP 080 1_7	50	80	200	4000	6000	15'	10'	7.0	400	1300	1400	97
MP 080 1_10	40	80	180	4000	6000	15'	10'	7.0	400	1300	1400	97
MP 080 2_9	40	80	180	2900	3500	15'	10'	5.9	400	1300	1400	94
MP 080 2_12	70	100	250	2900	3500	15'	10'	5.9	400	1300	1400	94
MP 080 2_15	70	100	250	2900	3500	15'	10'	5.9	400	1300	1400	94
MP 080 2_16	70	100	250	3100	4500	15'	10'	5.9	400	1300	1400	94
MP 080 2_20	70	100	250	3200	4500	15'	10'	5.9	400	1300	1400	94
MP 080 2_25	70	100	250	3200	4500	15'	10'	5.9	400	1300	1400	94
MP 080 2_28	70	100	250	4000	6000	15'	10'	5.9	400	1300	1400	94
MP 080 2_30	40	80	180	4000	6000	15'	10'	5.9	400	1300	1400	94
MP 080 2_35	70	100	250	4000	6000	15'	10'	5.9	400	1300	1400	94
MP 080 2_36	50	80	200	3200	4500	15'	10'	5.9	400	1300	1400	94
MP 080 2_40	70	100	250	4000	6000	15'	10'	5.9	400	1300	1400	94
MP 080 2_50	70	100	250	4000	6000	15'	10'	5.9	400	1300	1400	94
MP 080 2_70	70	100	250	4000	6000	15'	10'	5.9	400	1300	1400	94
MP 080 2_100	40	80	180	4000	6000	15'	10'	5.9	400	1300	1400	94
MP 080 3_48	70	100	250	3100	4500	17'	12'	5.4	400	1300	1400	90
MP 080 3_64	70	100	250	3100	4500	17'	12'	5.4	400	1300	1400	90
MP 080 3_75	70	100	250	3200	4500	17'	12'	5.4	400	1300	1400	90
MP 080 3_80	70	100	250	3100	4500	17'	12'	5.4	400	1300	1400	90
MP 080 3_84	70	100	250	4000	6000	17'	12'	5.4	400	1300	1400	90
MP 080 3_90	40	80	180	4000	6000	17'	12'	5.4	400	1300	1400	90
MP 080 3_120	70	100	250	4000	6000	17'	12'	5.4	400	1300	1400	90
MP 080 3_125	70	100	250	3200	4500	17'	12'	5.4	400	1300	1400	90
MP 080 3_140	70	100	250	4000	6000	17'	12'	5.4	400	1300	1400	90
MP 080 3_150	70	100	250	4000	6000	17'	12'	5.4	400	1300	1400	90
MP 080 3_160	70	100	250	4000	6000	17'	12'	5.4	400	1300	1400	90
MP 080 3_175	70	100	250	4000	6000	17'	12'	5.4	400	1300	1400	90
MP 080 3_200	70	100	250	4000	6000	17'	12'	5.4	400	1300	1400	90
MP 080 3_210	70	100	250	4000	6000	17'	12'	5.4	400	1300	1400	90
MP 080 3_216	70	100	250	3200	4500	17'	12'	5.4	400	1300	1400	90
MP 080 3_250	70	100	250	4000	6000	17'	12'	5.4	400	1300	1400	90
MP 080 3_280	70	100	250	4000	6000	17'	12'	5.4	400	1300	1400	90
MP 080 3_350	70	100	250	4000	6000	17'	12'	5.4	400	1300	1400	90
MP 080 3_400	70	100	250	4000	6000	17'	12'	5.4	400	1300	1400	90
MP 080 3_500	70	100	250	4000	6000	17'	12'	5.4	400	1300	1400	90
MP 080 3_700	70	100	250	4000	6000	17'	12'	5.4	400	1300	1400	90
MP 080 3_1000	40	80	180	4000	6000	17'	12'	5.4	400	1300	1400	90

If option **CR** (taper roller bearings) is specified: **R_{n2} = 2500 N** and **A_{n2} = 3000 N**.

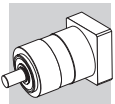

2.4 MP 105

MP 105												
i	M _{n2} [Nm]	M _{a2} [Nm]	M _{p2} [Nm]	n ₁ [min-1]	n _{1max} [min-1]	φ _S [arcmin]	φ _R [arcmin]	C _t [Nm/arcmin]	R _{n1} [N]	R _{n2} [N]	A _{n2} [N]	η %
MP 105 1_3	100	180	360	2500	3500	15'	10'	22.0	600	1500	1600	97
MP 105 1_4	140	210	450	2800	4500	15'	10'	22.0	600	1500	1600	97
MP 105 1_5	140	210	450	3000	4500	15'	10'	22.0	600	1500	1600	97
MP 105 1_6	140	210	450	3000	4500	15'	10'	22.0	600	1500	1600	97
MP 105 1_7	140	210	450	3500	5000	15'	10'	22.0	600	1500	1600	97
MP 105 1_10	100	180	360	3500	5000	15'	10'	22.0	600	1500	1600	97
MP 105 2_9	100	180	360	2500	3500	15'	10'	20.5	600	1500	1600	94
MP 105 2_12	170	250	600	2500	3500	15'	10'	20.5	600	1500	1600	94
MP 105 2_15	170	250	600	2500	3500	15'	10'	20.5	600	1500	1600	94
MP 105 2_16	170	250	600	2800	4500	15'	10'	20.5	600	1500	1600	94
MP 105 2_20	170	250	600	3000	4500	15'	10'	20.5	600	1500	1600	94
MP 105 2_25	170	250	600	3000	4500	15'	10'	20.5	600	1500	1600	94
MP 105 2_28	170	250	600	3500	5000	15'	10'	20.5	600	1500	1600	94
MP 105 2_30	100	180	360	3500	5000	15'	10'	20.5	600	1500	1600	94
MP 105 2_35	170	250	600	3500	5000	15'	10'	20.5	600	1500	1600	94
MP 105 2_36	140	210	450	3000	4500	15'	10'	20.5	600	1500	1600	94
MP 105 2_40	170	250	600	3500	5000	15'	10'	20.5	600	1500	1600	94
MP 105 2_50	170	250	600	3500	5000	15'	10'	20.5	600	1500	1600	94
MP 105 2_70	170	250	600	3500	5000	15'	10'	20.5	600	1500	1600	94
MP 105 2_100	100	180	360	3500	5000	15'	10'	20.5	600	1500	1600	94
MP 105 3_48	170	250	600	2800	4500	17'	12'	17.5	600	1500	1600	90
MP 105 3_64	170	250	600	2800	4500	17'	12'	17.5	600	1500	1600	90
MP 105 3_75	170	250	600	3000	4500	17'	12'	17.5	600	1500	1600	90
MP 105 3_80	170	250	600	2800	4500	17'	12'	17.5	600	1500	1600	90
MP 105 3_84	170	250	600	3500	5000	17'	12'	17.5	600	1500	1600	90
MP 105 3_90	100	180	360	3500	5000	17'	12'	17.5	600	1500	1600	90
MP 105 3_120	170	250	600	3500	5000	17'	12'	17.5	600	1500	1600	90
MP 105 3_125	170	250	600	3000	4500	17'	12'	17.5	600	1500	1600	90
MP 105 3_140	170	250	600	3500	5000	17'	12'	17.5	600	1500	1600	90
MP 105 3_150	170	250	600	3500	5000	17'	12'	17.5	600	1500	1600	90
MP 105 3_160	170	250	600	3500	5000	17'	12'	17.5	600	1500	1600	90
MP 105 3_175	170	250	600	3500	5000	17'	12'	17.5	600	1500	1600	90
MP 105 3_200	170	250	600	3500	5000	17'	12'	17.5	600	1500	1600	90
MP 105 3_210	170	250	600	3500	5000	17'	12'	17.5	600	1500	1600	90
MP 105 3_216	170	250	600	3000	4500	17'	12'	17.5	600	1500	1600	90
MP 105 3_250	170	250	600	3500	5000	17'	12'	17.5	600	1500	1600	90
MP 105 3_280	170	250	600	3500	5000	17'	12'	17.5	600	1500	1600	90
MP 105 3_350	170	250	600	3500	5000	17'	12'	17.5	600	1500	1600	90
MP 105 3_400	170	250	600	3500	5000	17'	12'	17.5	600	1500	1600	90
MP 105 3_500	170	250	600	3500	5000	17'	12'	17.5	600	1500	1600	90
MP 105 3_700	170	250	600	3500	5000	17'	12'	17.5	600	1500	1600	90
MP 105 3_1000	100	180	360	3500	5000	17'	12'	17.5	600	1500	1600	90

If option **CR** (taper roller bearings) is specified: **R_{n2} = 3800 N** and **A_{n2} = 4000 N**.

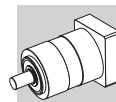

2.5 MP 130

MP 130												
i	M _{n2} [Nm]	M _{a2} [Nm]	M _{p2} [Nm]	n ₁ [min ⁻¹]	n _{1max} [min ⁻¹]	φ _S [arcmin]	φ _R [arcmin]	C _t [Nm/arcmin]	R _{n1} [N]	R _{n2} [N]	A _{n2} [N]	η %
MP 130 1_3	215	400	800	2100	3000	15'	10'	43.0	800	5500	6500	97
MP 130 1_4	380	600	1100	2400	3500	15'	10'	43.0	800	5500	6500	97
MP 130 1_5	380	600	1100	2900	3500	15'	10'	43.0	800	5500	6500	97
MP 130 1_6	380	600	1100	2900	3500	15'	10'	43.0	800	5500	6500	97
MP 130 1_7	380	600	1100	3200	4000	15'	10'	43.0	800	5500	6500	97
MP 130 1_10	215	400	800	3200	4000	15'	10'	43.0	800	5500	6500	97
MP 130 2_9	215	400	800	2100	3000	15'	10'	37.5	800	5500	6500	94
MP 130 2_12	450	700	1300	2100	3000	15'	10'	37.5	800	5500	6500	94
MP 130 2_15	450	700	1300	2100	3000	15'	10'	37.5	800	5500	6500	94
MP 130 2_16	450	700	1300	2400	3500	15'	10'	37.5	800	5500	6500	94
MP 130 2_20	450	700	1300	2900	3500	15'	10'	37.5	800	5500	6500	94
MP 130 2_25	450	700	1300	2900	3500	15'	10'	37.5	800	5500	6500	94
MP 130 2_28	450	700	1300	3200	4000	15'	10'	37.5	800	5500	6500	94
MP 130 2_30	215	400	800	3200	4000	15'	10'	37.5	800	5500	6500	94
MP 130 2_35	450	700	1300	3200	4000	15'	10'	37.5	800	5500	6500	94
MP 130 2_36	380	600	1100	2900	3500	15'	10'	37.5	800	5500	6500	94
MP 130 2_40	450	700	1300	3200	4000	15'	10'	37.5	800	5500	6500	94
MP 130 2_50	450	700	1300	3200	4000	15'	10'	37.5	800	5500	6500	94
MP 130 2_70	450	700	1300	3200	4000	15'	10'	37.5	800	5500	6500	94
MP 130 2_100	215	400	800	3200	4000	15'	10'	37.5	800	5500	6500	94
MP 130 3_48	450	700	1300	2400	3500	17'	12'	29.5	800	5500	6500	90
MP 130 3_64	450	700	1300	2400	3500	17'	12'	29.5	800	5500	6500	90
MP 130 3_75	450	700	1300	2900	3500	17'	12'	29.5	800	5500	6500	90
MP 130 3_80	450	700	1300	2400	3500	17'	12'	29.5	800	5500	6500	90
MP 130 3_84	450	700	1300	3200	4000	17'	12'	29.5	800	5500	6500	90
MP 130 3_90	215	400	800	3200	4000	17'	12'	29.5	800	5500	6500	90
MP 130 3_120	450	700	1300	3200	4000	17'	12'	29.5	800	5500	6500	90
MP 130 3_125	450	700	1300	2900	3500	17'	12'	29.5	800	5500	6500	90
MP 130 3_140	450	700	1300	3200	4000	17'	12'	29.5	800	5500	6500	90
MP 130 3_150	450	700	1300	3200	4000	17'	12'	29.5	800	5500	6500	90
MP 130 3_160	450	700	1300	3200	4000	17'	12'	29.5	800	5500	6500	90
MP 130 3_175	450	700	1300	3200	4000	17'	12'	29.5	800	5500	6500	90
MP 130 3_200	450	700	1300	3200	4000	17'	12'	29.5	800	5500	6500	90
MP 130 3_210	450	700	1300	3200	4000	17'	12'	29.5	800	5500	6500	90
MP 130 3_216	450	700	1300	2900	3500	17'	12'	29.5	800	5500	6500	90
MP 130 3_250	450	700	1300	3200	4000	17'	12'	29.5	800	5500	6500	90
MP 130 3_280	450	700	1300	3200	4000	17'	12'	29.5	800	5500	6500	90
MP 130 3_350	450	700	1300	3200	4000	17'	12'	29.5	800	5500	6500	90
MP 130 3_400	450	700	1300	3200	4000	17'	12'	29.5	800	5500	6500	90
MP 130 3_500	450	700	1300	3200	4000	17'	12'	29.5	800	5500	6500	90
MP 130 3_700	450	700	1300	3200	4000	17'	12'	29.5	800	5500	6500	90
MP 130 3_1000	215	400	800	3200	4000	17'	12'	29.5	800	5500	6500	90

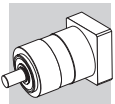

2.6 MP 160

MP 160												
i	M _{n2} [Nm]	M _{a2} [Nm]	M _{p2} [Nm]	n ₁ [min ⁻¹]	n _{1max} [min ⁻¹]	φ _S [arcmin]	φ _R [arcmin]	C _t [Nm/arcmin]	R _{n1} [N]	R _{n2} [N]	A _{n2} [N]	η %
MP 160 1_3	350	660	1200	1900	3000	15'	10'	90	1200	6500	7500	97
MP 160 1_4	500	750	1400	2200	3500	15'	10'	90	1200	6500	7500	97
MP 160 1_5	500	750	1400	2500	3500	15'	10'	90	1200	6500	7500	97
MP 160 1_6	500	750	1400	2500	3500	15'	10'	90	1200	6500	7500	97
MP 160 1_7	500	750	1400	3000	4000	15'	10'	90	1200	6500	7500	97
MP 160 1_10	350	660	1200	3000	4000	15'	10'	90	1200	6500	7500	97
MP 160 2_9	350	660	1200	1900	3000	15'	10'	83	1200	6500	7500	94
MP 160 2_12	700	950	1800	1900	3000	15'	10'	83	1200	6500	7500	94
MP 160 2_15	700	950	1800	1900	3000	15'	10'	83	1200	6500	7500	94
MP 160 2_16	700	950	1800	2200	3500	15'	10'	83	1200	6500	7500	94
MP 160 2_20	700	950	1800	2500	3500	15'	10'	83	1200	6500	7500	94
MP 160 2_25	700	950	1800	2500	3500	15'	10'	83	1200	6500	7500	94
MP 160 2_28	700	950	1800	3000	4000	15'	10'	83	1200	6500	7500	94
MP 160 2_30	350	660	1200	3000	4000	15'	10'	83	1200	6500	7500	94
MP 160 2_35	700	950	1800	3000	4000	15'	10'	83	1200	6500	7500	94
MP 160 2_36	500	750	1400	2500	3500	15'	10'	83	1200	6500	7500	94
MP 160 2_40	700	950	1800	3000	4000	15'	10'	83	1200	6500	7500	94
MP 160 2_50	700	950	1800	3000	4000	15'	10'	83	1200	6500	7500	94
MP 160 2_70	700	950	1800	3000	4000	15'	10'	83	1200	6500	7500	94
MP 160 2_100	350	660	1200	3000	4000	15'	10'	83	1200	6500	7500	94
MP 160 3_48	700	950	1800	2200	3500	17'	12'	60	1200	6500	7500	90
MP 160 3_64	700	950	1800	2200	3500	17'	12'	60	1200	6500	7500	90
MP 160 3_75	700	950	1800	2500	3500	17'	12'	60	1200	6500	7500	90
MP 160 3_80	700	950	1800	2200	3500	17'	12'	60	1200	6500	7500	90
MP 160 3_84	700	950	1800	3000	4000	17'	12'	60	1200	6500	7500	90
MP 160 3_90	350	660	1200	3000	4000	17'	12'	60	1200	6500	7500	90
MP 160 3_120	700	950	1800	3000	4000	17'	12'	60	1200	6500	7500	90
MP 160 3_125	700	950	1800	2500	3500	17'	12'	60	1200	6500	7500	90
MP 160 3_140	700	950	1800	3000	4000	17'	12'	60	1200	6500	7500	90
MP 160 3_150	700	950	1800	3000	4000	17'	12'	60	1200	6500	7500	90
MP 160 3_160	700	950	1800	3000	4000	17'	12'	60	1200	6500	7500	90
MP 160 3_175	700	950	1800	3000	4000	17'	12'	60	1200	6500	7500	90
MP 160 3_200	700	950	1800	3000	4000	17'	12'	60	1200	6500	7500	90
MP 160 3_210	700	950	1800	3000	4000	17'	12'	60	1200	6500	7500	90
MP 160 3_216	700	950	1800	2500	3500	17'	12'	60	1200	6500	7500	90
MP 160 3_250	700	950	1800	3000	4000	17'	12'	60	1200	6500	7500	90
MP 160 3_280	700	950	1800	3000	4000	17'	12'	60	1200	6500	7500	90
MP 160 3_350	700	950	1800	3000	4000	17'	12'	60	1200	6500	7500	90
MP 160 3_400	700	950	1800	3000	4000	17'	12'	60	1200	6500	7500	90
MP 160 3_500	700	950	1800	3000	4000	17'	12'	60	1200	6500	7500	90
MP 160 3_700	700	950	1800	3000	4000	17'	12'	60	1200	6500	7500	90
MP 160 3_1000	350	660	1200	3000	4000	17'	12'	60	1200	6500	7500	90

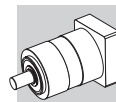

2.7 MP 190

MP 190											
i	M _{n2} [Nm]	M _{a2} [Nm]	M _{p2} [Nm]	n ₁ [min ⁻¹]	n _{1max} [min ⁻¹]	φ _s [arcmin]	φ _R [arcmin]	C _t [Nm/arcmin]	R _{n2} [N]	A _{n2} [N]	η %
MP 190 1_3	500	800	1400	1500	2500	15'	10'	130	14000	15000	97
MP 190 1_4	700	950	1800	2100	3000	15'	10'	130	14000	15000	97
MP 190 1_5	700	950	1800	2300	3000	15'	10'	130	14000	15000	97
MP 190 1_6	700	950	1800	2300	3000	15'	10'	130	14000	15000	97
MP 190 1_7	700	950	1800	2900	3500	15'	10'	130	14000	15000	97
MP 190 1_10	500	800	1400	2900	3500	15'	10'	130	14000	15000	97
MP 190 2_9	500	800	1400	1500	2500	15'	10'	100	14000	15000	94
MP 190 2_12	1000	1200	2200	1500	2500	15'	10'	100	14000	15000	94
MP 190 2_15	1000	1200	2200	1500	2500	15'	10'	100	14000	15000	94
MP 190 2_16	1000	1200	2200	2100	3000	15'	10'	100	14000	15000	94
MP 190 2_20	1000	1200	2200	2300	3000	15'	10'	100	14000	15000	94
MP 190 2_25	1000	1200	2200	2300	3000	15'	10'	100	14000	15000	94
MP 190 2_28	1000	1200	2200	2900	3500	15'	10'	100	14000	15000	94
MP 190 2_30	500	800	1400	2900	3500	15'	10'	100	14000	15000	94
MP 190 2_35	1000	1200	2200	2900	3500	15'	10'	100	14000	15000	94
MP 190 2_36	700	950	1800	2300	3000	15'	10'	100	14000	15000	94
MP 190 2_40	1000	1200	2200	2900	3500	15'	10'	100	14000	15000	94
MP 190 2_50	1000	1200	2200	2900	3500	15'	10'	100	14000	15000	94
MP 190 2_70	1000	1200	2200	2900	3500	15'	10'	100	14000	15000	94
MP 190 2_100	500	800	1400	2900	3500	15'	10'	100	14000	15000	94
MP 190 3_48	1000	1200	2200	2100	3000	17'	12'	90	14000	15000	90
MP 190 3_64	1000	1200	2200	2100	3000	17'	12'	90	14000	15000	90
MP 190 3_75	1000	1200	2200	2300	3000	17'	12'	90	14000	15000	90
MP 190 3_80	1000	1200	2200	2100	3000	17'	12'	90	14000	15000	90
MP 190 3_84	1000	1200	2200	2900	3500	17'	12'	90	14000	15000	90
MP 190 3_90	500	800	1400	2900	3500	17'	12'	90	14000	15000	90
MP 190 3_120	1000	1200	2200	2900	3500	17'	12'	90	14000	15000	90
MP 190 3_125	1000	1200	2200	2300	3000	17'	12'	90	14000	15000	90
MP 190 3_140	1000	1200	2200	2900	3500	17'	12'	90	14000	15000	90
MP 190 3_150	1000	1200	2200	2900	3500	17'	12'	90	14000	15000	90
MP 190 3_160	1000	1200	2200	2900	3500	17'	12'	90	14000	15000	90
MP 190 3_175	1000	1200	2200	2900	3500	17'	12'	90	14000	15000	90
MP 190 3_200	1000	1200	2200	2900	3500	17'	12'	90	14000	15000	90
MP 190 3_210	1000	1200	2200	2900	3500	17'	12'	90	14000	15000	90
MP 190 3_250	1000	1200	2200	2900	3500	17'	12'	90	14000	15000	90
MP 190 3_280	1000	1200	2200	2900	3500	17'	12'	90	14000	15000	90
MP 190 3_350	1000	1200	2200	2900	3500	17'	12'	90	14000	15000	90
MP 190 3_400	1000	1200	2200	2900	3500	17'	12'	90	14000	15000	90
MP 190 3_500	1000	1200	2200	2900	3500	17'	12'	90	14000	15000	90
MP 190 3_700	1000	1200	2200	2900	3500	17'	12'	90	14000	15000	90
MP 190 3_1000	500	800	1400	2900	3500	17'	12'	90	14000	15000	90

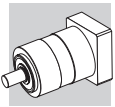

2.8 PERMITTED AXIAL AND RADIAL FORCES FOR VERSION MP ... MB

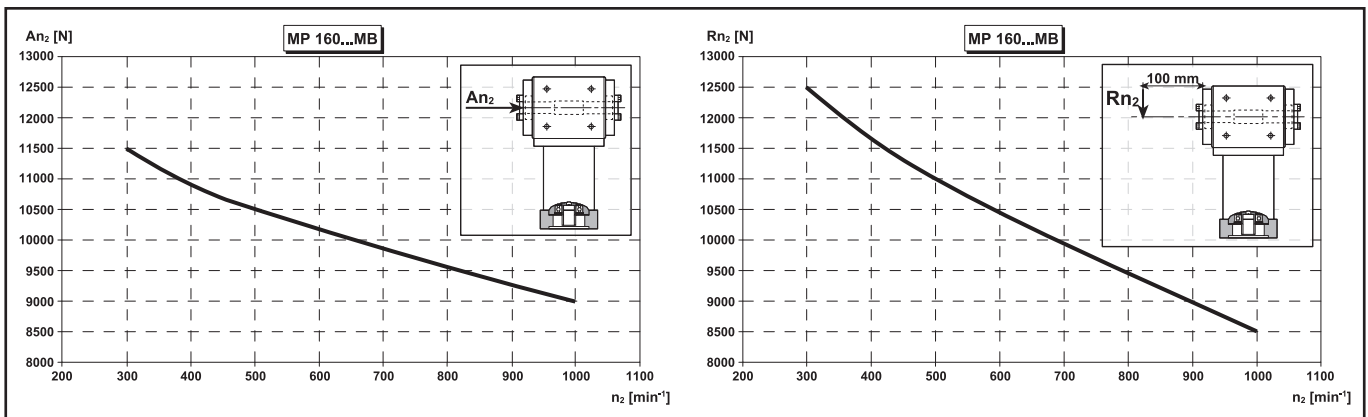
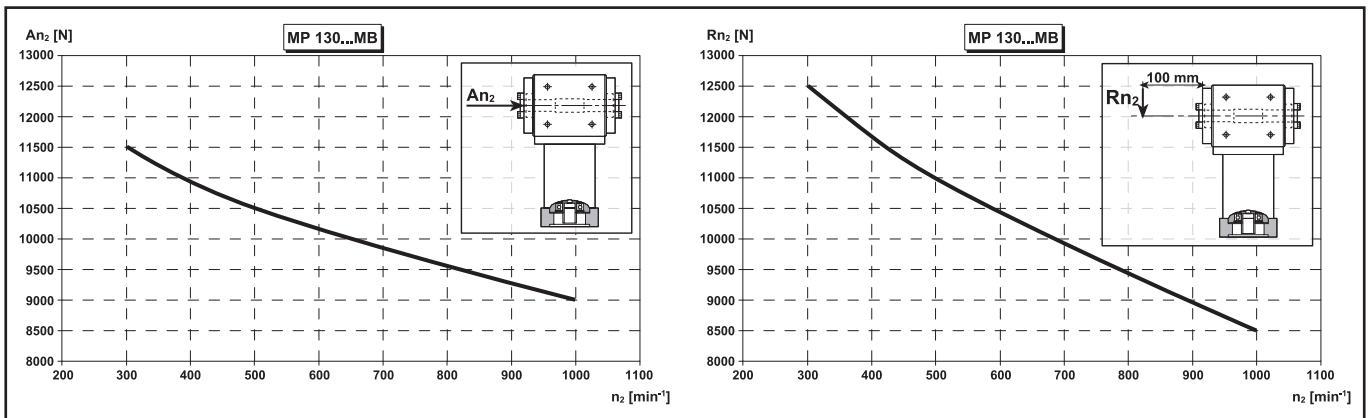
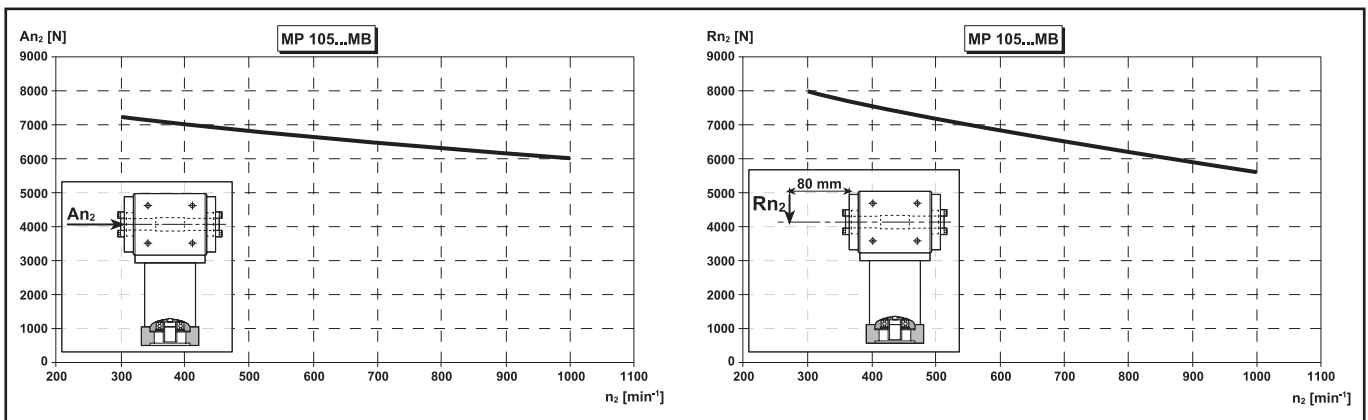
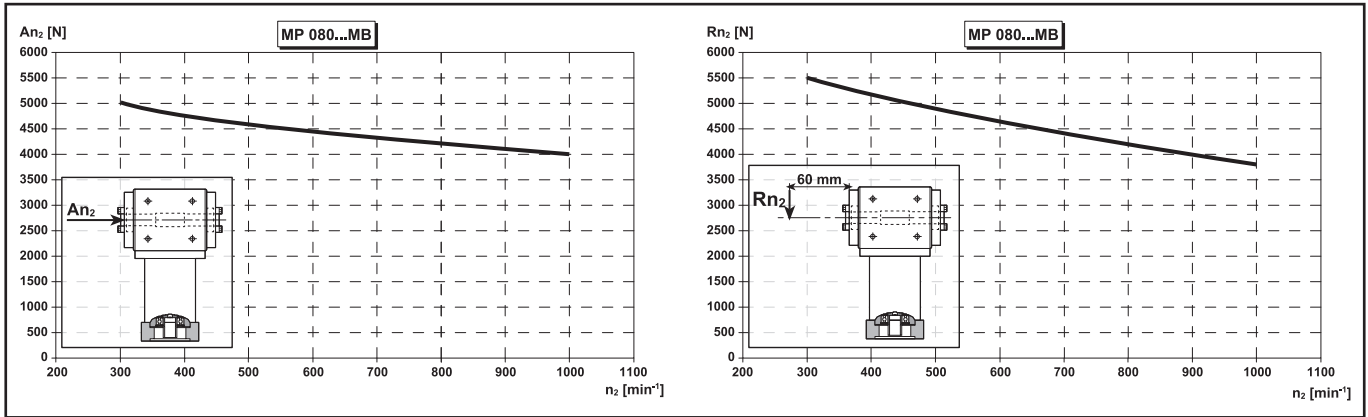

Thrust loads refer to an average duration of 10,000 h

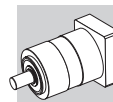

2.9 MASS MOMENT OF INERTIA

2.9.1 MP 053

MP 053		
i	J [kgcm ²]	
	D = Ø6...Ø9.52	D = Ø11...Ø14
MP 053 1_3	0.06	0.08
MP 053 1_4	0.05	0.06
MP 053 1_5	0.04	0.06
MP 053 1_6	0.03	0.05
MP 053 1_7	0.03	0.05
MP 053 1_9	0.03	0.05
MP 053 2_12	0.06	0.08
MP 053 2_15	0.06	0.08
MP 053 2_16	0.05	0.06
MP 053 2_20	0.04	0.06
MP 053 2_25	0.04	0.06
MP 053 2_28	0.03	0.05
MP 053 2_35	0.03	0.05
MP 053 2_36	0.03	0.05
MP 053 2_45	0.03	0.05
MP 053 2_81	0.03	0.05
MP 053 3_48	0.05	0.07
MP 053 3_60	0.05	0.07
MP 053 3_64	0.05	0.06
MP 053 3_75	0.04	0.06
MP 053 3_80	0.05	0.06
MP 053 3_84	0.03	0.05
MP 053 3_100	0.04	0.06
MP 053 3_112	0.03	0.05
MP 053 3_125	0.04	0.06
MP 053 3_140	0.03	0.05
MP 053 3_144	0.03	0.05
MP 053 3_175	0.03	0.05
MP 053 3_180	0.03	0.05
MP 053 3_216	0.03	0.05
MP 053 3_225	0.03	0.05
MP 053 3_245	0.03	0.05
MP 053 3_252	0.05	0.06
MP 053 3_324	0.03	0.05
MP 053 3_405	0.03	0.05
MP 053 3_567	0.03	0.05
MP 053 3_729	0.03	0.05

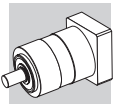

2.9.2 MP 060

MP 060		
i	J [kgcm ²]	
	D = Ø6...Ø9.52	D = Ø11...Ø14
MP 060 1_3	0.10	0.11
MP 060 1_4	0.06	0.08
MP 060 1_5	0.05	0.07
MP 060 1_6	0.04	0.06
MP 060 1_7	0.04	0.06
MP 060 1_10	0.03	0.05
MP 060 2_9	0.10	0.12
MP 060 2_12	0.10	0.11
MP 060 2_15	0.09	0.11
MP 060 2_16	0.06	0.08
MP 060 2_20	0.05	0.07
MP 060 2_25	0.05	0.06
MP 060 2_28	0.04	0.06
MP 060 2_30	0.03	0.05
MP 060 2_35	0.04	0.06
MP 060 2_36	0.04	0.06
MP 060 2_40	0.03	0.05
MP 060 2_50	0.03	0.05
MP 060 2_70	0.03	0.05
MP 060 2_100	0.03	0.05
MP 060 3_48	0.06	0.08
MP 060 3_64	0.06	0.08
MP 060 3_75	0.05	0.07
MP 060 3_80	0.06	0.08
MP 060 3_84	0.04	0.06
MP 060 3_90	0.03	0.05
MP 060 3_120	0.03	0.05
MP 060 3_125	0.05	0.07
MP 060 3_140	0.04	0.06
MP 060 3_150	0.03	0.05
MP 060 3_160	0.03	0.05
MP 060 3_175	0.04	0.06
MP 060 3_200	0.03	0.05
MP 060 3_210	0.03	0.05
MP 060 3_216	0.04	0.06
MP 060 3_250	0.03	0.05
MP 060 3_280	0.03	0.05
MP 060 3_350	0.03	0.05
MP 060 3_400	0.03	0.05
MP 060 3_500	0.03	0.05
MP 060 3_700	0.03	0.05
MP 060 3_1000	0.03	0.05

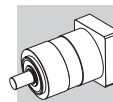

2.9.3 MP 080

MP 080		
i	J [kgcm ²]	
	D = Ø8...Ø12.7	D = Ø14...Ø19
MP 080 1_3	0.50	0.59
MP 080 1_4	0.34	0.43
MP 080 1_5	0.28	0.37
MP 080 1_6	0.21	0.30
MP 080 1_7	0.23	0.32
MP 080 1_10	0.20	0.29
MP 080 2_9	0.49	0.58
MP 080 2_12	0.47	0.56
MP 080 2_15	0.46	0.55
MP 080 2_16	0.32	0.41
MP 080 2_20	0.27	0.36
MP 080 2_25	0.27	0.36
MP 080 2_28	0.22	0.31
MP 080 2_30	0.20	0.29
MP 080 2_35	0.22	0.31
MP 080 2_36	0.20	0.29
MP 080 2_40	0.20	0.29
MP 080 2_50	0.19	0.28
MP 080 2_70	0.19	0.28
MP 080 2_100	0.19	0.28
MP 080 3_48	0.33	0.42
MP 080 3_64	0.32	0.41
MP 080 3_75	0.27	0.36
MP 080 3_80	0.32	0.41
MP 080 3_84	0.23	0.32
MP 080 3_90	0.20	0.29
MP 080 3_120	0.20	0.29
MP 080 3_125	0.27	0.36
MP 080 3_140	0.22	0.31
MP 080 3_150	0.20	0.29
MP 080 3_160	0.20	0.29
MP 080 3_175	0.22	0.31
MP 080 3_200	0.20	0.29
MP 080 3_210	0.20	0.29
MP 080 3_216	0.20	0.29
MP 080 3_250	0.19	0.28
MP 080 3_280	0.19	0.28
MP 080 3_350	0.19	0.28
MP 080 3_400	0.19	0.28
MP 080 3_500	0.19	0.28
MP 080 3_700	0.19	0.28
MP 080 3_1000	0.19	0.28

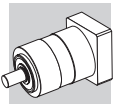

2.9.4 MP 105

MP 105				
i	J [kgcm ²]			
	D = Ø11...Ø12.7	D = Ø14...Ø19	D = Ø22...Ø24	D = Ø28...Ø32
MP 105 1_3	1.7	1.8	2.2	2.6
MP 105 1_4	0.99	1.1	1.5	1.9
MP 105 1_5	0.72	0.79	1.23	1.6
MP 105 1_6	0.36	0.43	0.88	1.2
MP 105 1_7	0.47	0.55	0.99	1.4
MP 105 1_10	0.33	0.41	0.85	1.2
MP 105 2_9	1.6	1.6	2.1	2.4
MP 105 2_12	1.5	1.6	2.0	2.4
MP 105 2_15	1.5	1.5	2.0	2.4
MP 105 2_16	0.87	0.95	1.4	1.8
MP 105 2_20	0.86	0.93	1.4	1.7
MP 105 2_25	0.63	0.71	1.1	1.5
MP 105 2_28	0.43	0.51	0.95	1.3
MP 105 2_30	0.32	0.40	0.84	1.2
MP 105 2_35	0.43	0.50	0.95	1.3
MP 105 2_36	0.32	0.39	0.84	1.2
MP 105 2_40	0.31	0.39	0.83	1.2
MP 105 2_50	0.31	0.39	0.83	1.2
MP 105 2_70	0.31	0.38	0.83	1.2
MP 105 2_100	0.31	0.38	0.83	1.2
MP 105 3_48	0.91	0.98	1.4	1.8
MP 105 3_64	0.87	0.94	1.4	1.7
MP 105 3_75	0.66	0.74	1.2	1.5
MP 105 3_80	0.86	0.94	1.4	1.7
MP 105 3_84	0.44	0.52	0.96	1.3
MP 105 3_90	0.32	0.39	0.84	1.2
MP 105 3_120	0.32	0.39	0.84	1.2
MP 105 3_125	0.63	0.70	1.1	1.5
MP 105 3_140	0.43	0.51	0.95	1.3
MP 105 3_150	0.32	0.39	0.84	1.2
MP 105 3_160	0.31	0.39	0.83	1.2
MP 105 3_175	0.43	0.50	0.95	1.3
MP 105 3_200	0.31	0.39	0.83	1.2
MP 105 3_210	0.32	0.39	0.84	1.2
MP 105 3_216	0.31	0.39	0.83	1.2
MP 105 3_250	0.31	0.39	0.83	1.2
MP 105 3_280	0.31	0.38	0.83	1.2
MP 105 3_350	0.31	0.38	0.83	1.2
MP 105 3_400	0.31	0.38	0.83	1.2
MP 105 3_500	0.31	0.38	0.83	1.2
MP 105 3_700	0.31	0.38	0.83	1.2
MP 105 3_1000	0.31	0.38	0.83	1.2

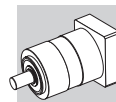

2.9.5 MP 130

MP 130				
i	J [kgcm ²]			
	D = Ø14...Ø19	D = Ø22...Ø24	D = Ø28...Ø32	D = Ø35...Ø38
MP 130 1_3	5.3	5.5	5.8	7.2
MP 130 1_4	3.1	3.3	3.6	5.0
MP 130 1_5	2.2	2.4	2.8	4.1
MP 130 1_6	1.2	1.4	1.7	3.1
MP 130 1_7	1.5	1.7	2.0	3.4
MP 130 1_10	1.0	1.2	1.6	3.0
MP 130 2_9	4.8	5.0	5.4	6.7
MP 130 2_12	4.6	4.8	5.1	6.5
MP 130 2_15	4.5	4.7	5.0	6.4
MP 130 2_16	2.7	2.9	3.2	4.6
MP 130 2_20	2.0	2.2	2.5	3.9
MP 130 2_25	1.9	2.1	2.5	3.8
MP 130 2_28	1.3	1.6	1.9	3.3
MP 130 2_30	1.0	1.2	1.6	2.9
MP 130 2_35	1.3	1.5	1.9	3.2
MP 130 2_36	1.1	1.3	1.6	3.0
MP 130 2_40	0.98	1.2	1.5	2.9
MP 130 2_50	0.97	1.2	1.5	2.9
MP 130 2_70	0.96	1.2	1.5	2.9
MP 130 2_100	0.96	1.2	1.5	2.9
MP 130 3_48	2.8	3.0	3.3	4.7
MP 130 3_64	2.6	2.9	3.2	4.6
MP 130 3_75	2.0	2.2	2.6	3.9
MP 130 3_80	2.6	2.9	3.2	4.6
MP 130 3_84	1.4	1.6	1.9	3.3
MP 130 3_90	1.0	1.2	1.6	2.9
MP 130 3_120	0.99	1.20	1.55	2.90
MP 130 3_125	1.9	2.1	2.5	3.8
MP 130 3_140	1.3	1.5	1.9	3.2
MP 130 3_150	0.99	1.2	1.6	2.9
MP 130 3_160	0.98	1.2	1.5	2.9
MP 130 3_175	1.3	1.5	1.9	3.2
MP 130 3_200	0.97	1.2	1.5	2.9
MP 130 3_210	0.99	1.2	1.6	2.9
MP 130 3_216	1.0	1.3	1.6	3.0
MP 130 3_250	0.97	1.2	1.5	2.9
MP 130 3_280	0.96	1.2	1.5	2.9
MP 130 3_350	0.96	1.2	1.5	2.9
MP 130 3_400	0.96	1.2	1.5	2.9
MP 130 3_500	0.96	1.2	1.5	2.9
MP 130 3_700	0.96	1.2	1.5	2.9
MP 130 3_1000	0.96	1.2	1.5	2.9

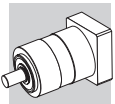

2.9.6 MP 160

MP 160				
i	J [kgcm ²]			
	D = Ø14...Ø19	D = Ø22...Ø24	D = Ø28...Ø32	D = Ø35...Ø38
MP 160 1_3	8.4	8.6	8.9	10.3
MP 160 1_4	4.7	4.9	5.2	6.6
MP 160 1_5	3.3	3.5	3.8	5.2
MP 160 1_6	1.3	1.5	1.9	3.2
MP 160 1_7	2.0	2.2	2.6	3.9
MP 160 1_10	1.3	1.5	1.9	3.2
MP 160 2_9	7.5	7.7	8.1	9.4
MP 160 2_12	7.1	7.3	7.7	9.0
MP 160 2_15	6.9	7.1	7.5	8.9
MP 160 2_16	4.0	4.2	4.5	5.9
MP 160 2_20	2.8	3.0	3.4	4.7
MP 160 2_25	2.8	3.0	3.3	4.7
MP 160 2_28	1.8	2.0	2.4	3.7
MP 160 2_30	1.2	1.5	1.8	3.2
MP 160 2_35	1.8	2.0	2.3	3.7
MP 160 2_36	1.1	1.3	1.6	3.0
MP 160 2_40	1.2	1.4	1.8	3.1
MP 160 2_50	1.2	1.4	1.8	3.1
MP 160 2_70	1.2	1.4	1.7	3.1
MP 160 2_100	1.2	1.4	1.7	3.1
MP 160 3_48	4.1	4.3	4.7	6.0
MP 160 3_64	3.9	4.1	4.5	5.8
MP 160 3_75	2.9	3.1	3.5	4.8
MP 160 3_80	3.9	4.1	4.5	5.8
MP 160 3_84	1.8	2.1	2.4	3.8
MP 160 3_90	1.2	1.4	1.8	3.1
MP 160 3_120	1.2	1.4	1.8	3.1
MP 160 3_125	2.7	2.9	3.3	4.6
MP 160 3_140	1.8	2.0	2.3	3.7
MP 160 3_150	1.2	1.4	1.8	3.1
MP 160 3_160	1.2	1.4	1.8	3.1
MP 160 3_175	1.8	2.0	2.3	3.7
MP 160 3_200	1.2	1.4	1.8	3.1
MP 160 3_210	1.2	1.4	1.8	3.1
MP 160 3_216	1.1	1.3	1.6	3.0
MP 160 3_250	1.2	1.4	1.7	3.1
MP 160 3_280	1.2	1.4	1.7	3.1
MP 160 3_350	1.2	1.4	1.7	3.1
MP 160 3_400	1.2	1.4	1.7	3.1
MP 160 3_500	1.2	1.4	1.7	3.1
MP 160 3_700	1.2	1.4	1.7	3.1
MP 160 3_1000	1.2	1.4	1.7	3.1

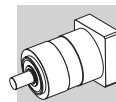

2.9.7 MP 190

MP 190					
J [kgcm ²]					
i	D = Ø14...Ø24	D = Ø28...Ø32	D = Ø35...Ø38	Ø42	D = Ø45...Ø48
MP 190 1_3	24.2	24.9	25.6	29.3	29.9
MP 190 1_4	13.4	14.1	14.9	18.5	19.1
MP 190 1_5	9.3	10.0	10.8	14.4	15.0
MP 190 1_6	2.9	3.6	4.3	8.0	8.6
MP 190 1_7	5.7	6.4	7.1	10.8	11.4
MP 190 1_10	3.6	4.2	5.0	8.7	9.3
MP 190 2_9	23.2	23.9	24.7	28.3	28.9
MP 190 2_12	22.0	22.7	23.5	27.1	27.7
MP 190 2_15	21.6	22.3	23.0	26.7	27.3
MP 190 2_16	12.2	12.9	13.6	17.3	17.9
MP 190 2_20	8.5	9.2	10.0	13.6	14.2
MP 190 2_25	8.4	9.1	9.8	13.5	14.1
MP 190 2_28	5.3	6.0	6.7	10.4	11.0
MP 190 2_30	3.5	4.2	4.9	8.6	9.2
MP 190 2_35	5.2	5.9	6.6	10.3	10.9
MP 190 2_36	2.2	2.9	3.6	7.3	7.9
MP 190 2_40	3.4	4.1	4.8	8.5	9.1
MP 190 2_50	3.3	4.0	4.8	8.4	9.0
MP 190 2_70	3.3	4.0	4.7	8.4	9.0
MP 190 2_100	3.3	4.0	4.7	8.4	9.0
MP 190 3_48	12.7	13.4	14.2	17.8	18.4
MP 190 3_64	12.1	12.8	13.5	17.2	17.8
MP 190 3_75	8.9	9.5	10.3	14.0	14.6
MP 190 3_80	12.1	12.8	13.5	17.2	17.8
MP 190 3_84	5.5	6.1	6.9	10.6	11.2
MP 190 3_90	3.5	4.1	4.9	8.6	9.2
MP 190 3_120	3.5	4.1	4.9	8.6	9.2
MP 190 3_125	8.3	9.0	9.8	13.4	14.0
MP 190 3_140	5.2	5.9	6.7	10.3	10.9
MP 190 3_150	3.5	4.1	4.9	8.6	9.2
MP 190 3_160	3.4	4.0	4.8	8.5	9.1
MP 190 3_175	5.2	5.9	6.6	10.3	10.9
MP 190 3_200	3.4	4.0	4.8	8.5	9.1
MP 190 3_210	3.5	4.1	4.9	8.6	9.2
MP 190 3_250	3.3	4.0	4.8	8.4	9.0
MP 190 3_280	3.3	4.0	4.7	8.4	9.0
MP 190 3_350	3.3	4.0	4.7	8.4	9.0
MP 190 3_400	3.3	4.0	4.7	8.4	9.0
MP 190 3_500	3.3	4.0	4.7	8.4	9.0
MP 190 3_700	3.3	4.0	4.7	8.4	9.0
MP 190 3_1000	3.3	4.0	4.7	8.4	9.0

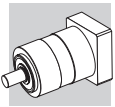

3 DIMENSIONS

3.1 MP 053

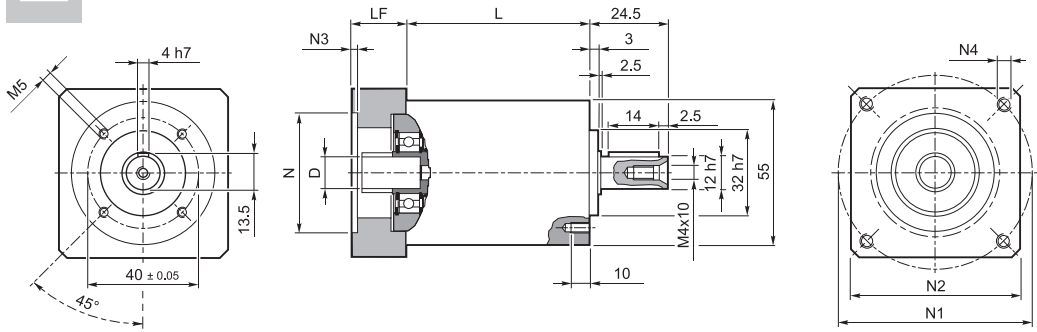

	L	
MP 053 1	53	0.8
MP 053 2	66.8	1.0
MP 053 3	80.6	1.3

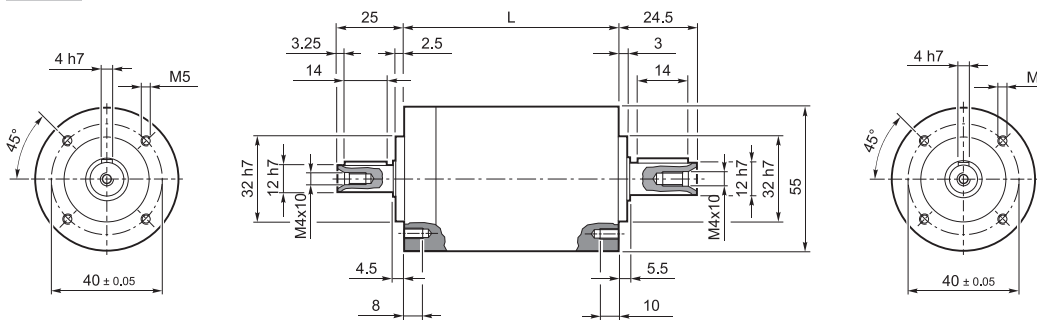
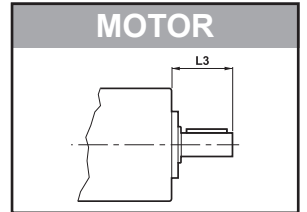

	L	
MP 053 1	58.2	0.8
MP 053 2	72	1.0
MP 053 3	85.8	1.3

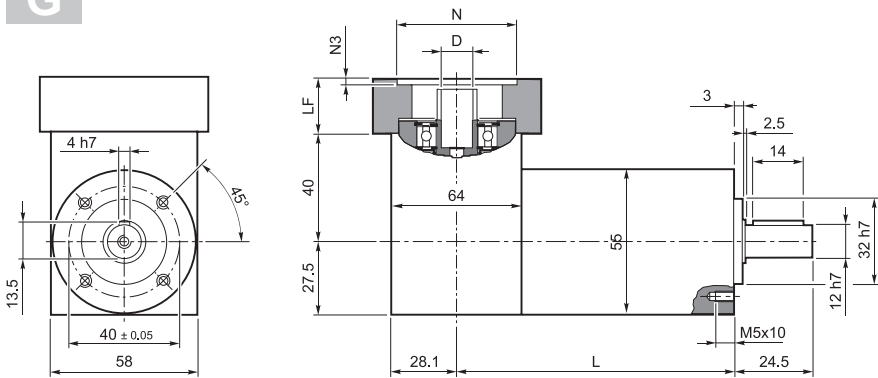

	L	
MP 053 1	88.9	1.3
MP 053 2	102.7	1.5
MP 053 3	116.5	1.8

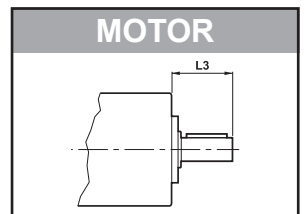

	D	N	N1	N2	N3	N4	LF	L3
MP 053_ 6...9 25 25...40 36...48	≤ 9 mm	25...40	36...48	55	3.5	4.5	25	25
MP 053_ 6...12 25 38.1 66.6	≤ 12 mm	38.1	66.6	60	3	M4x10	18	25
MP 053_ 6...12 25 40 63		40	63	60	3	M4x10	18	25
MP 053_ 6...12 25 50 60		50	60	60	3	M4x10	18	25
MP 053_ 6...12 23 50 65 TH		50	65	55	4	5.5	16	23
MP 053_ 6...12 25 60 75		60	75	63	3	M5x12	18	25
MP 053_ 6...12 25 60 75 TH*		60	75	65	3	5.5	18	25
MP 053_ 6...14 30 50 65	≤ 14 mm	50	65	60	3	M5x12	23	30
MP 053_ 6...14 30 50 65 TH		50	65	60	4	5.5	23	30
MP 053_ 6...14 30 50 70		50	70	60	3	M4x10	23	30
MP 053_ 6...14 30 60 75		60	75	63	3	M5x12	23	30
MP 053_ 6...14 30 60 75 TH*		60	75	65	3	5.5	23	30
MP 053_ 6...14 30 60 85		60	85	75	3	M5x12	23	30
MP 053_ 6...14 30 60 90		60	90	75	3	M5x12	23	30
MP 053_ 6...14 30 70 85		70	85	75	3	M6x15	23	30
MP 053_ 6...14 30 70 90		70	90	75	3	M5x12	23	30
MP 053_ 6...14 32 73 98.4		73	98.4	85	3	M5x12	25	32
MP 053_ 6...14 30 80 100	80	100	85	3	M6x15	23	30	

* cannot be used with version G

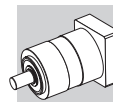

3.2 MP 060

I

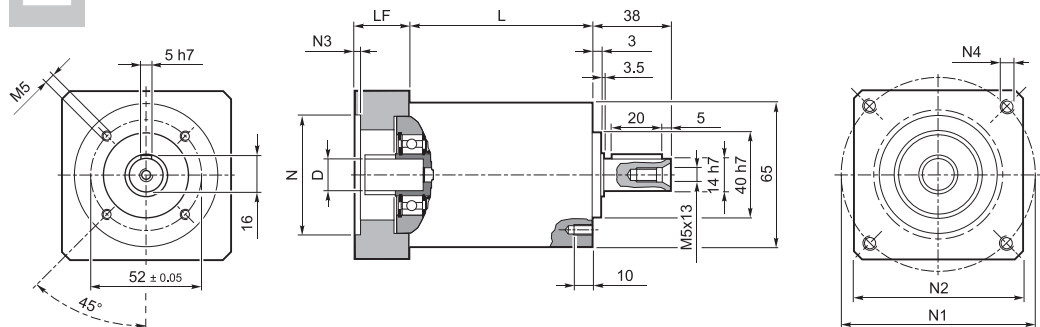

	L	
MP 060 1	57.55	1.2
MP 060 2	74.25	1.7
MP 060 3	90.95	2.0

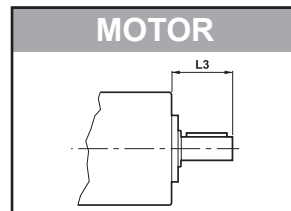

IS

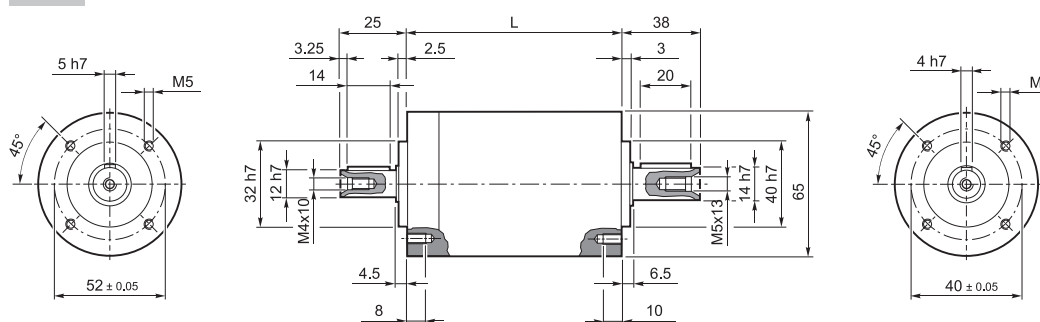

	L	
MP 060 1	62.75	1.2
MP 060 2	79.45	1.7
MP 060 3	96.15	2.0

G

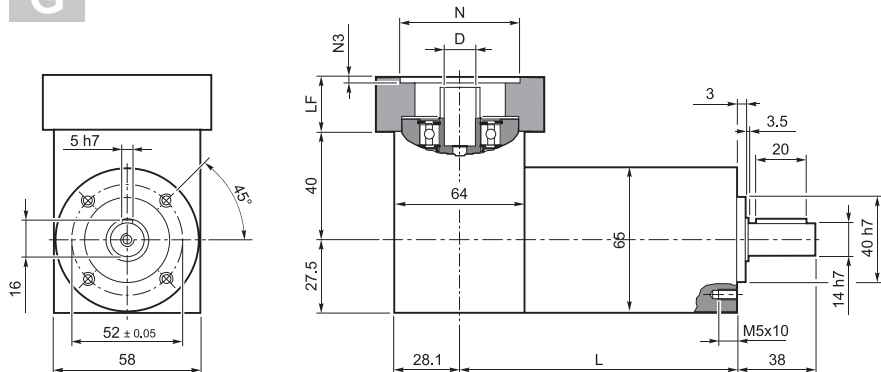

	L	
MP 060 1	93.45	1.7
MP 060 2	110.15	2.2
MP 060 3	126.85	2.5

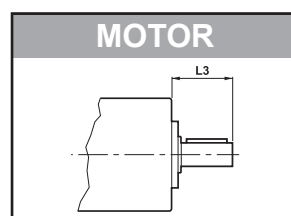

	D	N	N1	N2	N3	N4	LF	L3
MP 060_ 6...9 25 25...40 39...56	≤ 9 mm	25...40	39...56	65	3.5	4.5	25	25
MP 060_ 6...12 25 38.1 66.6	≤ 12 mm	38.1	66.6	60	3	$M4 \times 10$	18	25
MP 060_ 6...12 25 40 63		40	63	60	3	$M4 \times 10$	18	25
MP 060_ 6...12 25 50 60		50	60	60	3	$M4 \times 10$	18	25
MP 060_ 6...12 23 55 80 TH		55	80	65	2	5.5	16	23
MP 060_ 6...12 25 60 75		60	75	63	3	$M5 \times 12$	18	25
MP 060_ 6...12 25 60 75 TH*		60	75	65	3	5.5	18	25
MP 060_ 6...14 30 50 65	≤ 14 mm	50	65	60	3	$M5 \times 12$	23	30
MP 060_ 6...14 30 50 65 TH		50	65	60	3	5.5	25	30
MP 060_ 6...14 30 50 70		50	70	60	3	$M4 \times 10$	23	30
MP 060_ 6...14 30 60 75		60	75	63	3	$M5 \times 12$	23	30
MP 060_ 6...14 30 60 75 TH*		60	75	65	3	5.5	23	30
MP 060_ 6...14 30 60 85		60	85	75	3	$M5 \times 12$	23	30
MP 060_ 6...14 30 60 90		60	90	75	3	$M5 \times 12$	23	30
MP 060_ 6...14 30 70 85		70	85	75	3	$M6 \times 15$	23	30
MP 060_ 6...14 30 70 90		70	90	75	3	$M5 \times 12$	23	30
MP 060_ 6...14 32 73 98.4		73	98.4	85	3	$M5 \times 12$	25	32
MP 060_ 6...14 30 80 100	80	100	85	3	$M6 \times 15$	23	30	

* cannot be used with version G

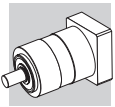

3.3 MP 080

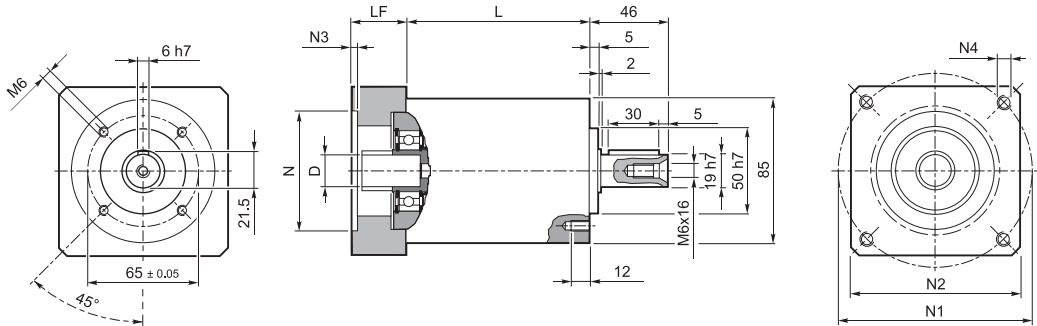

	L	
MP 080 1	83.5	4.0
MP 080 2	108.0	4.6
MP 080 3	132.5	5.2

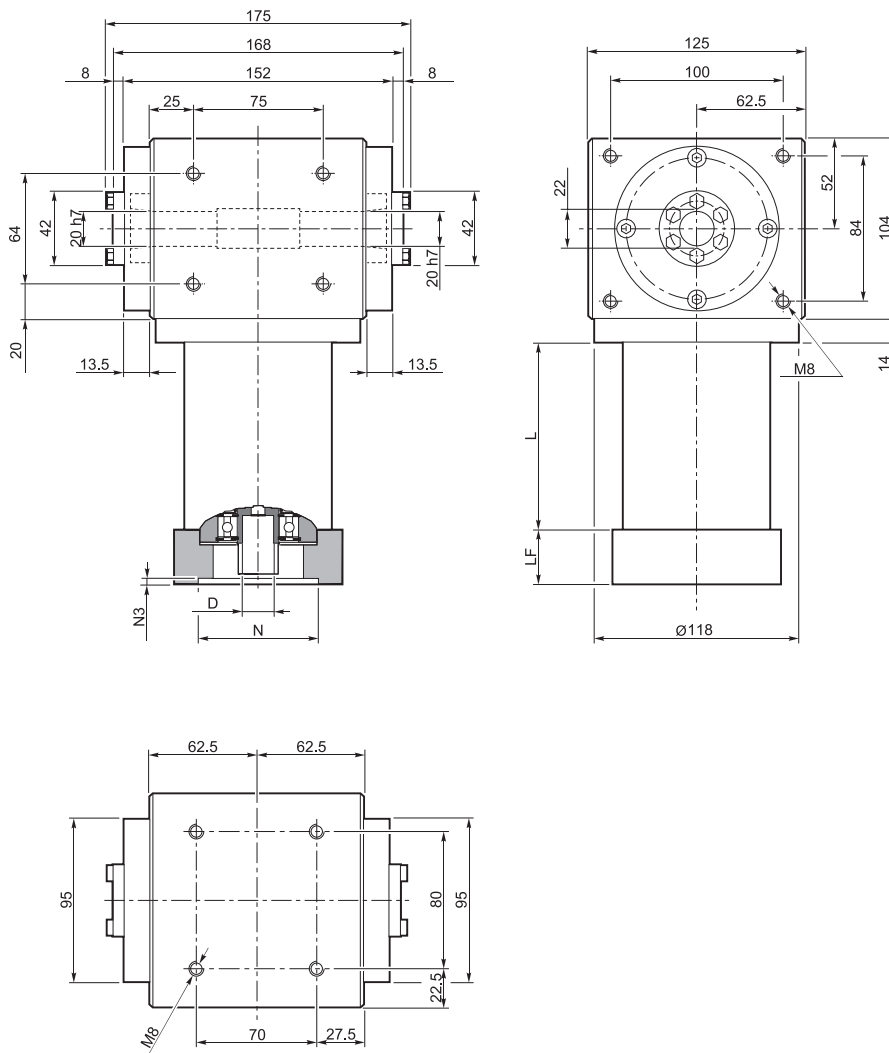
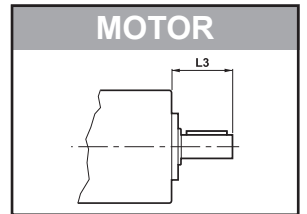

	L	
MP 080 1	83.5	14
MP 080 2	108	15
MP 080 3	132.5	16

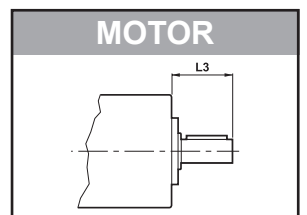

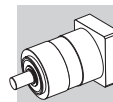

IS

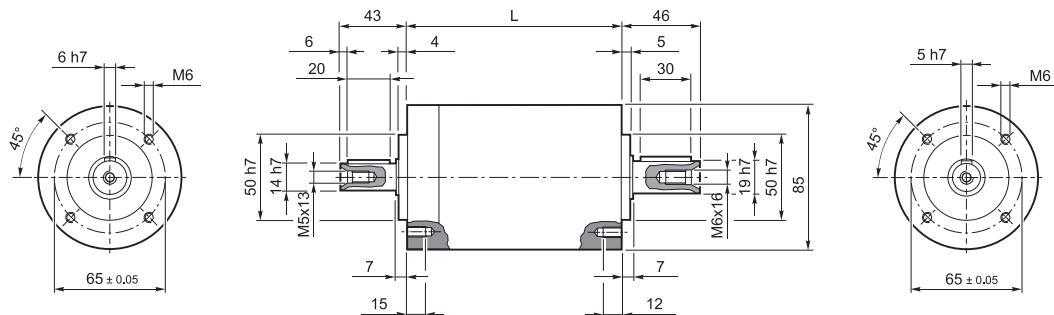

	L	
MP 080 1	105.3	4
MP 080 2	129.8	4.6
MP 080 3	154.3	5.2

G

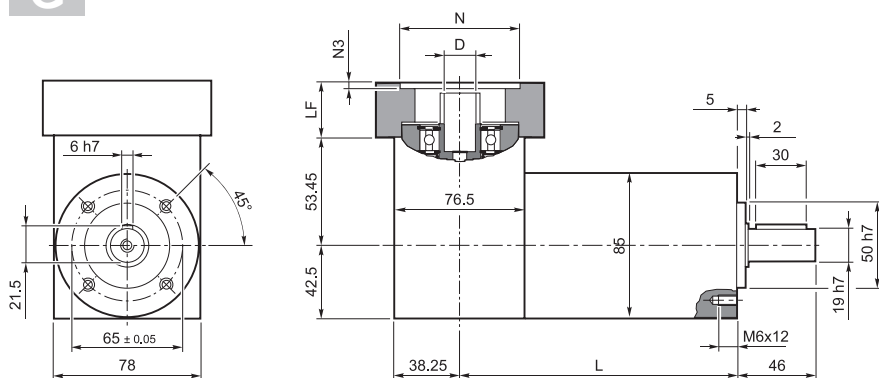

	L	
MP 080 1	143.55	5.2
MP 080 2	168.05	5.8
MP 080 3	192.55	6.4

MOTOR

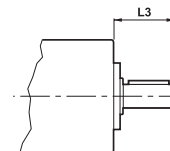

	D	N	N1	N2	N3	N4	LF	L3
MP 080_ 8...12 40 45 63	≤ 12 mm	45	63	80	-	M4x10	34	40
MP 080_ 8...14 40 40 63		40	63	80	-	M4x10	34	40
MP 080_ 8...14 40 50 65		50	65	80	4	M5x16	34	40
MP 080_ 8...14 40 50 65 TH		50	65	80	4	Ø5.5	34	40
MP 080_ 8...14 40 50 70		50	70	80	4	M4x10	34	40
MP 080_ 8...14 40 50 95	≤ 14 mm	50	95	80	4	M6x10	34	40
MP 080_ 8...14 40 60 75		60	75	80	4	M5x16	34	40
MP 080_ 8...14 40 60 75 TH		60	75	80	4	Ø5.5	34	40
MP 080_ 8...14 40 73 98.4		73	98.4	85	4	M5x16	34	40
MP 080_ 8...14 40 78 63.5		78	63.5	90	4	Ø6.5	34	40
MP 080_ 8...16 40 60 85	≤ 16 mm	60	85	80	4	M5x16	34	40
MP 080_ 8...16 40 60 90		60	90	80	4	M5x16	34	40
MP 080_ 8...19 40 55.5 125.7		55.5	125.7	105	4	M6x16	34	40
MP 080_ 8...19 40 70 85		70	85	80	4	M6x20	34	40
MP 080_ 8...19 40 70 85 TH		70	85	80	4	Ø6.5	34	40
MP 080_ 8...19 40 70 90		70	90	80	4	M5x16	34	40
MP 080_ 8...19 40 80 100	≤ 19 mm	80	100	90	4	M6x16	34	40
MP 080_ 8...19 40 95 115		95	115	100	4	M8x20	34	40
MP 080_ 8...19 40 95 130		95	130	115	4	M8x20	34	40
MP 080_ 8...19 40 110 130		110	130	115	4	M8x20	34	40
MP 080_ 8...19 50 110 145		110	145	120	6.5	M8x20	44	50
MP 080_ 8...19 60 110 145		110	145	120	6.5	M8x20	54	60

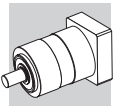

3.4 MP 105

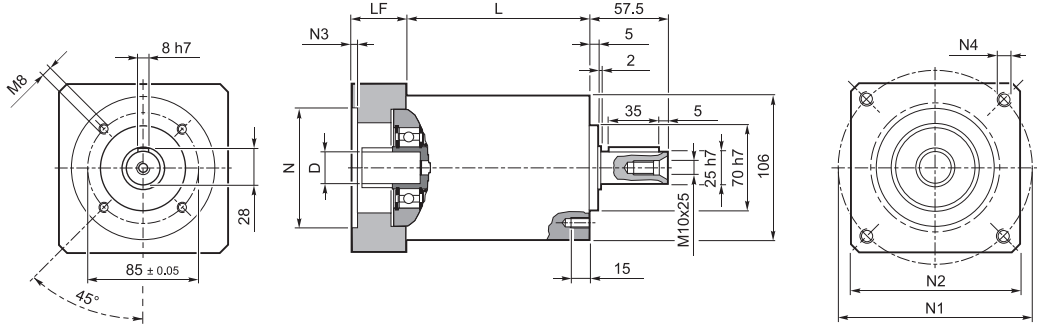

	L	
MP 105 1	107.5	6.5
MP 105 2	140	8.5
MP 105 3	172.5	10.5

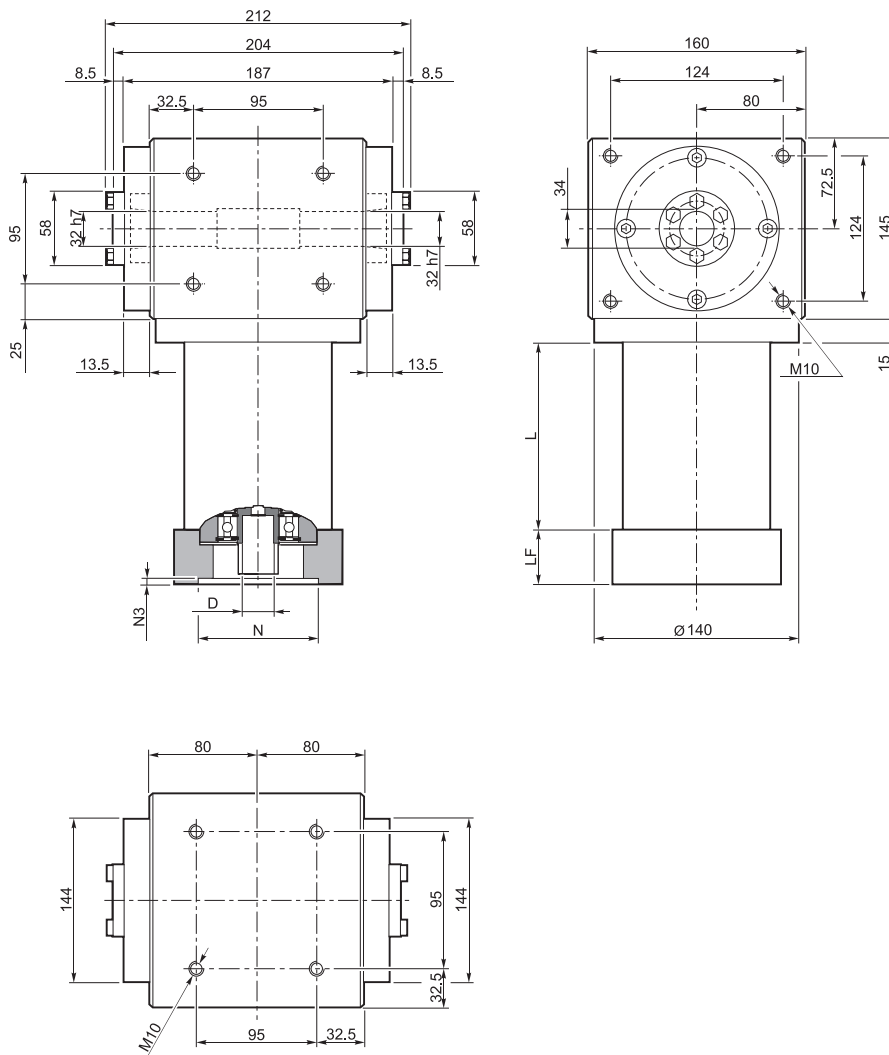
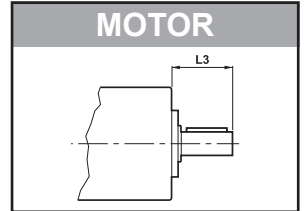

	L	
MP 105 1	107.5	32
MP 105 2	140	34
MP 105 3	172.5	36

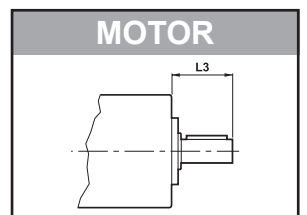

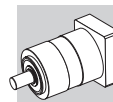

IS

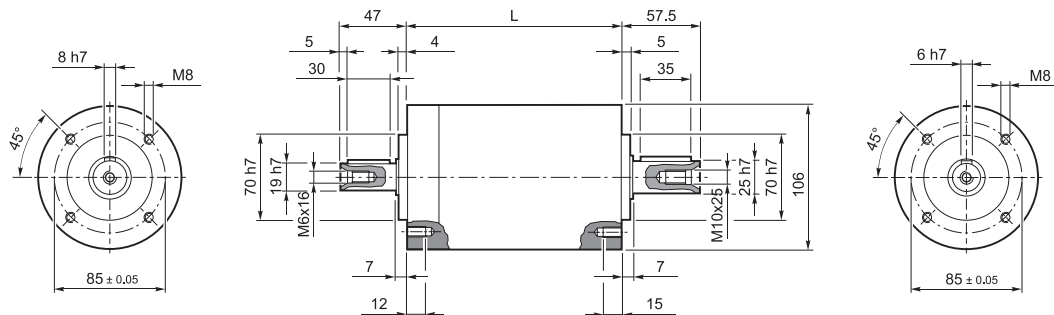

	L	
MP 105 1	121.3	6.5
MP 105 2	153.8	8.5
MP 105 3	186.3	10.5

G

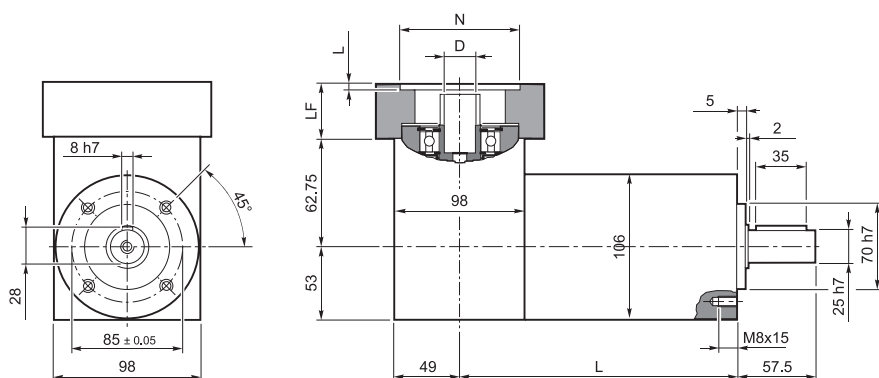

	L	
MP 105 1	170.3	8.5
MP 105 2	202.8	10.5
MP 105 3	235.3	12.5

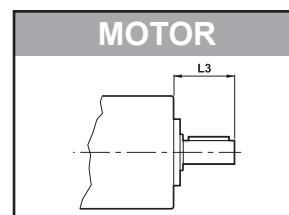

	D	N	N1	N2	N3	N4	LF	L3
MP 105_ 11...19 40 50 95		50	95	100	5	M6x14	28	40
MP 105_ 11...19 40 55.5 125.7		55.5	125.7	105	5	M6x16	28	40
MP 105_ 11...19 40 60 75		60	75	100	5	M5x14	28	40
MP 105_ 11...19 40 60 75 TH		60	75	100	5	5	33	40
MP 105_ 11...19 40 60 85		60	85	100	6.5	M5x14	28	40
MP 105_ 11...19 40 70 85		70	85	100	5	M6x14	28	40
MP 105_ 11...19 40 70 85 TH	≤ 19 mm	70	85	100	5	6	33	40
MP 105_ 11...19 40 70 90		70	90	100	5	M5x12	28	40
MP 105_ 11...19 40 80 100		80	100	100	5	M6x16	28	40
MP 105_ 11...19 40 80 100 TH		80	100	100	5	Ø6.5	28	40
MP 105_ 11...19 40 95 115		95	115	100	5	M8x18	28	40
MP 105_ 11...19 40 95 130		95	130	115	5	M8x18	28	40
MP 105_ 11...19 40 110 130		110	130	115	5	M8x18	28	40
MP 105_ 11...24 50 95 115		95	115	100	5	M8x18	38	50
MP 105_ 11...24 50 110 130		110	130	115	6.5	M8x20	38	50
MP 105_ 11...24 50 110 145	≤ 24 mm	110	145	120	6.5	M8x20	38	50
MP 105_ 11...24 60 110 145		110	145	120	6.5	M8x20	48	60
MP 105_ 11...24 50 130 165		130	165	140	6.5	M10x20	38	50
MP 105_ 11...32 60 130 165	≤ 32 mm	130	165	140	6.5	M10x25	48	60

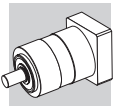

3.5 MP 130

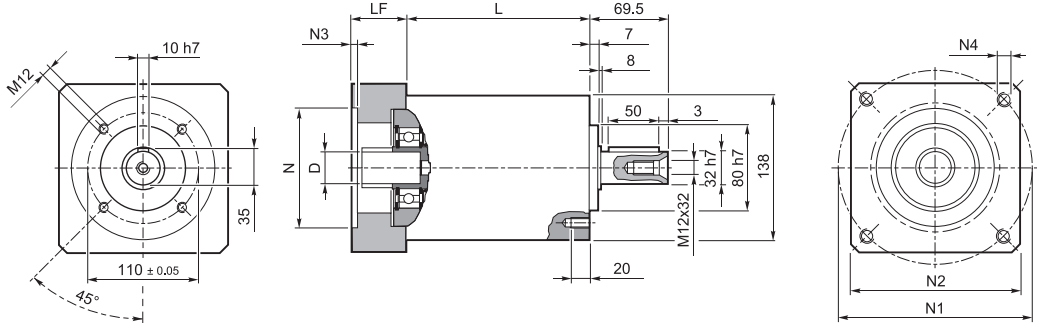

	L	
MP 130 1	126	12
MP 130 2	165.5	15.5
MP 130 3	205	18.5

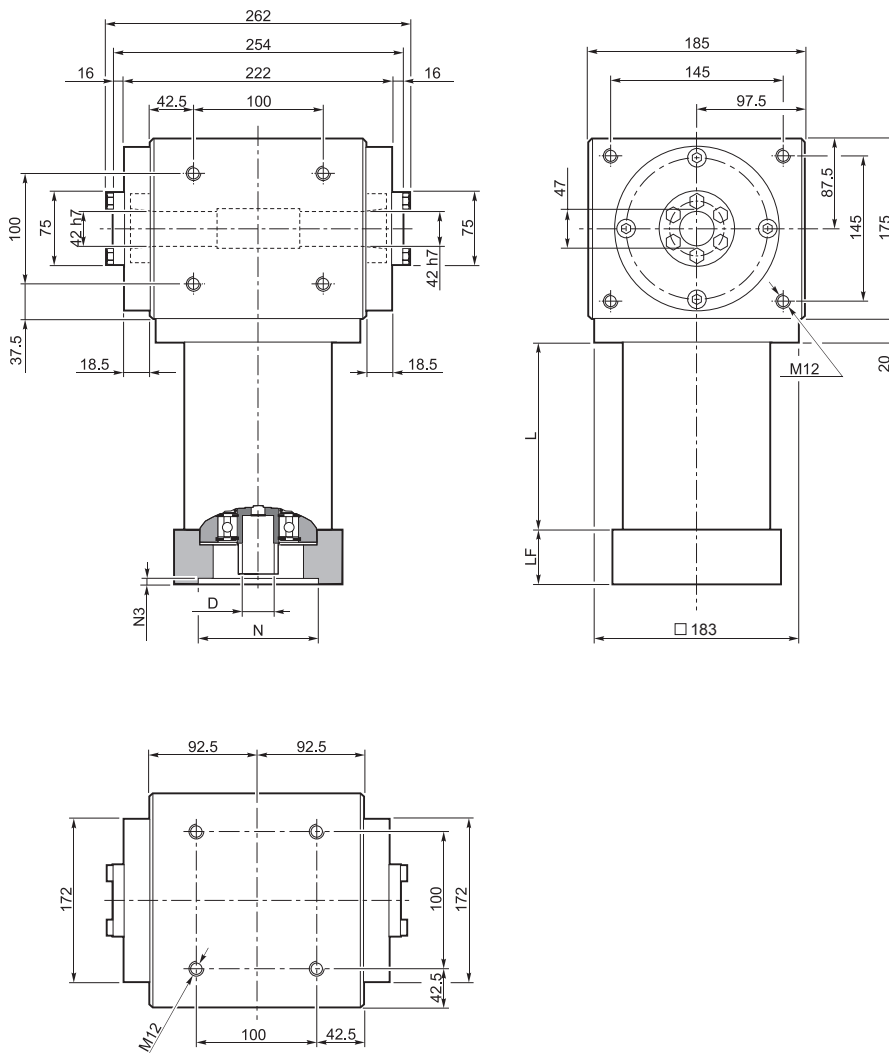
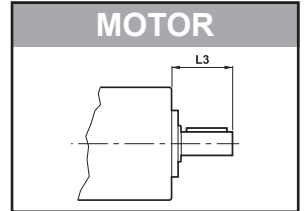

	L	
MP 130 1	126	54
MP 130 2	165.5	58
MP 130 3	205	61

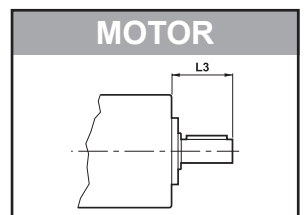

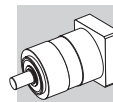

IS

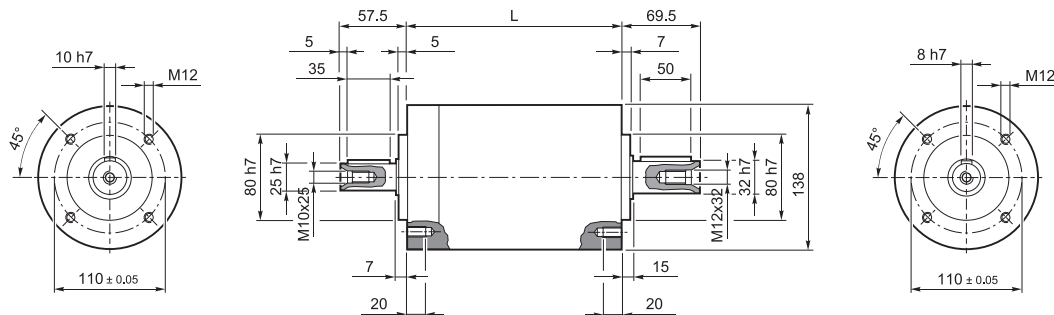

	L	
MP 130 1	151.2	12
MP 130 2	190.7	15.5
MP 130 3	230.2	18.5

G

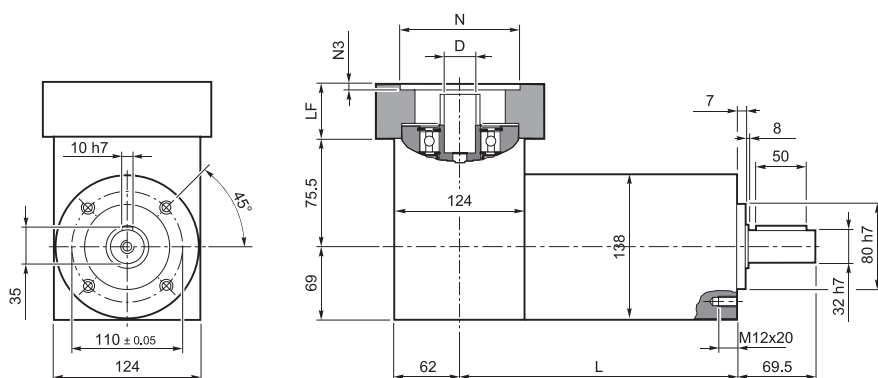

	L	
MP 130 1	213.2	16
MP 130 2	252.7	19.5
MP 130 3	292.2	22.5

MOTOR

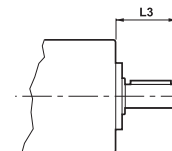

	D	N	N1	N2	N3	N4	LF	L3
MP 130_ 14...19 50 55.5 125.7	≤ 19 mm	55.5	125.7	130	4	M6x15	39.5	50
MP 130_ 14...19 50 80 100		80	100	130	4	M6x15	39.5	50
MP 130_ 14...24 50 95 115		95	115	130	4	M8x20	39.5	50
MP 130_ 14...24 50 110 130	≤ 24 mm	110	130	130	4	M8x20	39.5	50
MP 130_ 14...24 60 110 145		110	145	130	6.5	M8x20	49.5	60
MP 130_ 14...24 50 130 165		130	165	140	4	M10x20	39.5	50
MP 130_ 14...24 80 114.3 200		114.3	200	170	5.5	M14x25	38.5	50
MP 130_ 14...32 60 130 165	≤ 32 mm	130	165	140	4	M10x20	49.5	60
MP 130_ 14...32 60 180 215		180	215	190	5.5	M14x25	49.5	60
MP 130_ 14...38 80 114.3 200	≤ 38 mm	114.3	200	170	5.5	M12x25	69.5	80
MP 130_ 14...38 80 180 215		180	215	190	5.5	M14x25	69.5	80

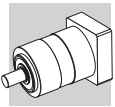

3.6 MP 160

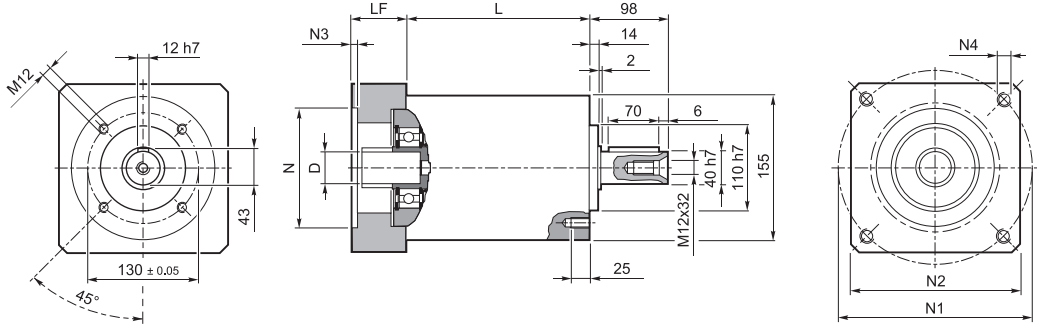

	L	
MP 160 1	130	17
MP 160 2	169.5	21
MP 160 3	209	28

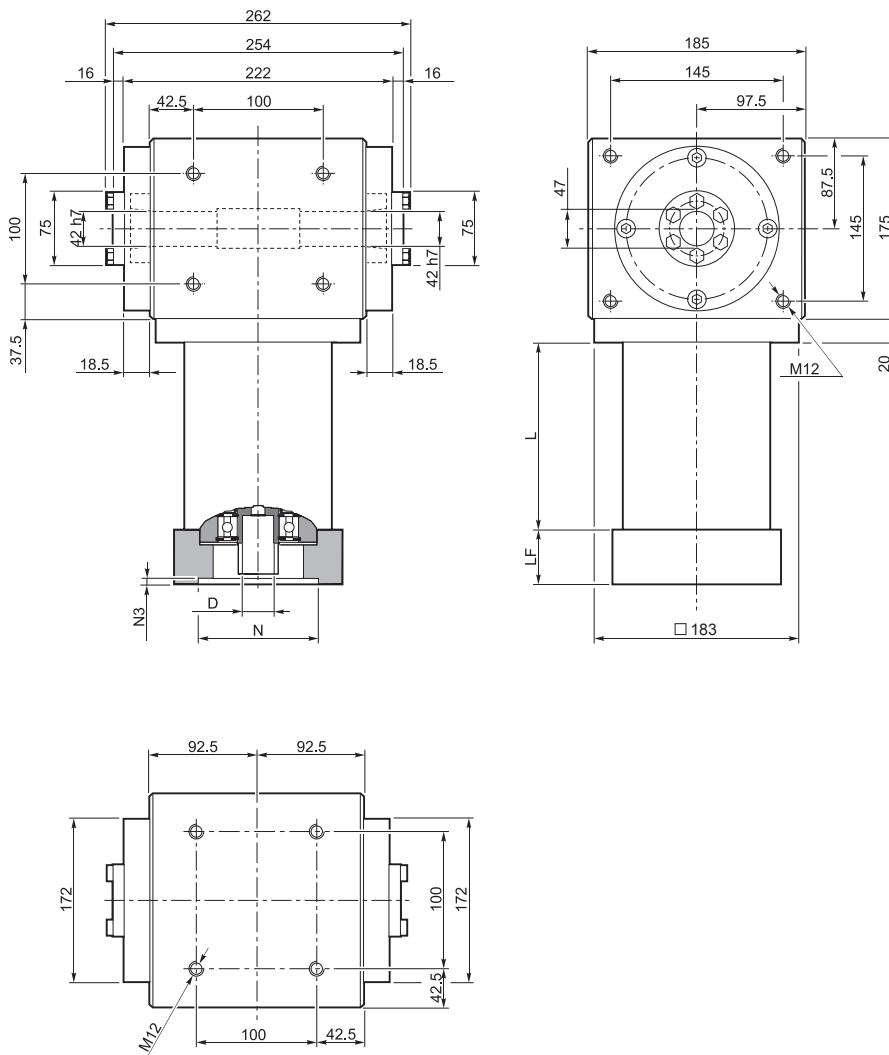
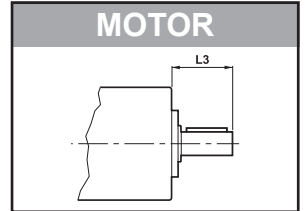

	L	
MP 160 1	130	54
MP 160 2	169.5	58
MP 160 3	209	61

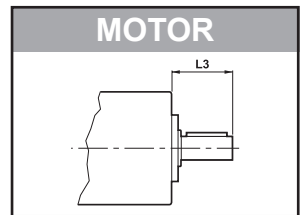

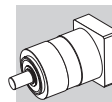

IS

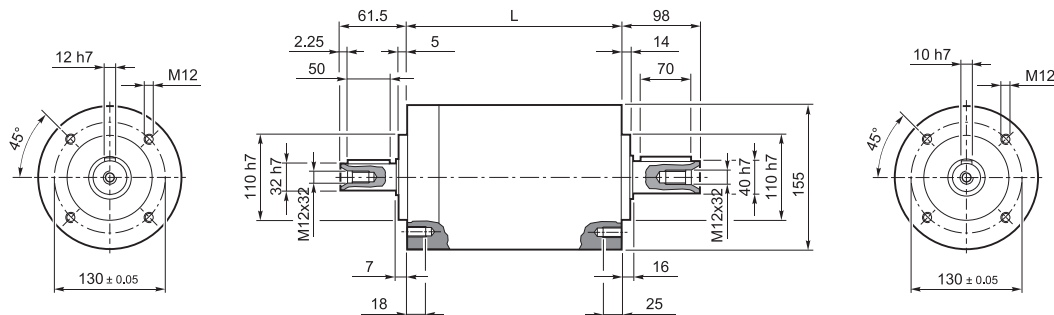

	L	
MP 160 1	155.2	17
MP 160 2	194.7	21
MP 160 3	234.2	28

G

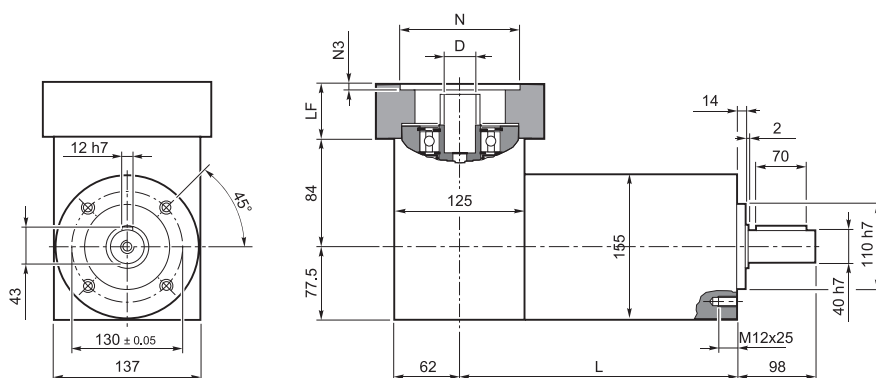

	L	
MP 160 1	218.2	24
MP 160 2	257.7	28
MP 160 3	297.2	34

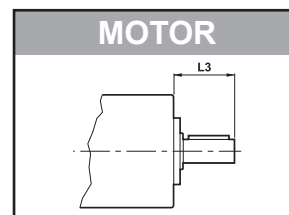

	D	N	N1	N2	N3	N4	LF	L3
MP 160_ 14...19 50 55.5 125.7	$\leq 19\text{ mm}$	55.5	125.7	140	5	M6x15	39.5	50
MP 160_ 14...19 50 80 100		80	100	140	5	M6x15	39.5	50
MP 160_ 14...24 50 95 115	$\leq 24\text{ mm}$	95	115	140	5	M8x20	39.5	50
MP 160_ 14...24 50 110 130		110	130	140	5	M8x20	39.5	50
MP 160_ 14...24 60 110 145		110	145	140	6.5	M8x20	49.5	60
MP 160_ 14...24 50 130 165	$\leq 32\text{ mm}$	130	165	140	5	M10x20	39.5	50
MP 160_ 14...32 60 130 165		130	165	140	5	M10x20	49.5	60
MP 160_ 14...32 60 180 215		180	215	190	5.5	M14x25	49.5	60
MP 160_ 14...38 80 114.3 200	$\leq 38\text{ mm}$	114.3	200	170	6.5	M12x25	69.5	80
MP 160_ 14...38 80 180 215		180	215	190	6.5	M14x25	69.5	80

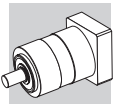

3.7 MP 190

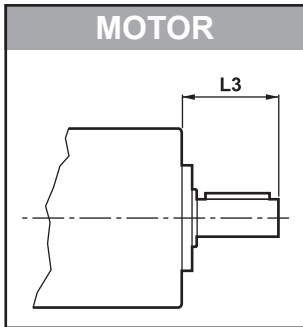
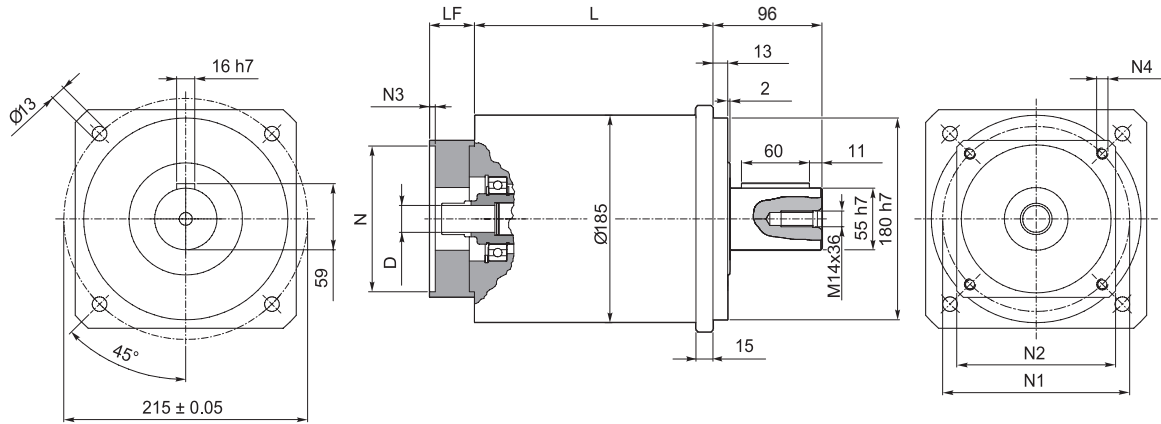

	L	kg
MP 190 1	158.7	25
MP 190 2	210.4	29
MP 190 3	262.1	34

	D	N	N1	N2	N3	N4	LF	L3
MP 190_ 14...19 50 55.5 125.7	≤ 19 mm	55.5	125.7	140	5	M6x15	39.5	50
MP 190_ 14...19 50 80 100		80	100	140	5	M6x15	39.5	50
MP 190_ 14...24 50 95 115	≤ 24 mm	95	115	140	5	M8x20	39.5	50
MP 190_ 14...24 50 110 130		110	130	140	5	M8x20	39.5	50
MP 190_ 14...24 60 110 145		110	145	140	6.5	M8x20	49.5	60
MP 190_ 14...24 50 130 165		130	165	140	5	M10x20	39.5	50
MP 190_ 14...32 60 130 165	≤ 32 mm	130	165	140	5	M10x20	49.5	60
MP 190_ 14...32 60 180 215		180	215	190	5.5	M14x25	49.5	60
MP 190_ 14...48 80 114.3 200	≤ 48 mm	114.3	200	170	6.5	M12x25	69.5	80
MP 190_ 14...48 80 180 215		180	215	190	6.5	M14x25	69.5	80

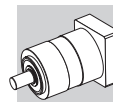

3.8 GEARBOX WITHOUT MOTOR ADAPTER

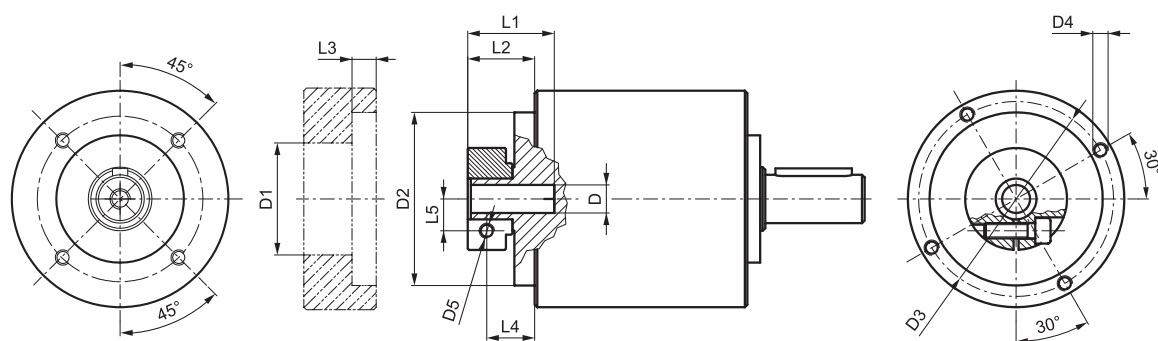

	D (F7)	D1	D2 (h7)	D3	D4	D5	L1	L2	L3 +0.1 +0.2	L4	L5
MP 053	6 -6.35 -7	32.5	50	42.5	M4x8	M4	21.7	13.2	3	8.2	8
	8 -9 -9.52 -10	32.5	50	42.5	M4x8	M4	21.7	13.2	3	8.2	9
	11 -12 -12.7	35.5	50	42.5	M4x8	M4	22	13.5	3	8.5	11
	14	35.5	50	42.5	M4x8	M4	25	17	3	10.2	11.5
MP 060	6 -6.35 -7	32.5	50	42.5	M4x8	M4	21.7	13.2	3	8.2	8
	8 -9 -9.52 -10	32.5	50	42.5	M4x8	M4	21.7	13.2	3	8.2	9
	11 -12 -12.7	35.5	50	42.5	M4x8	M4	22	13.5	3	8.5	11
	14	35.5	50	42.5	M4x8	M4	25	17	3	10.2	11.5
MP 080	8 -9 -9.52	38	68	76.5	M6x10	M6	34	26.3	9.5	18.8	10.5
	11 -12 -12.7	43	68	76.5	M6x10	M6	34	26.3	9.5	18.8	12.5
	14 -15.875 -16 -17	48	68	76.5	M6x10	M6	34	26.3	9.5	18.8	14.5
	19 -19.05	51	68	76.5	M6x10	M6	34	26.3	9.5	18.8	16.5
MP 105	11 -12 -12.7	43	90	98	M6x15	M6	33.5	20	7.6	12.5	12.5
	14 -15 -15.875 -16	48	90	98	M6x15	M6	33.5	20	7.6	12.5	14.5
	19	51	90	98	M6x15	M6	33.5	20	7.6	12.5	16.5
	22 -24	56.5	90	98	M6x15	M6	36.5	23	7.6	14	19
	28	67	90	98	M6x15	M8	36.5	23	7.6	14	22.5
	32	71	90	98	M6x15	M8	38	24.5	7.6	15.5	24.5
MP 130	14 -15.875 -16	48	113	125.5	M8x15	M6	40	27.5	6	20	14.5
	19	51	113	125.5	M8x15	M6	40	27.5	6	20	16.5
	22 -24	56.5	113	125.5	M8x15	M6	41	28.5	6	19.5	19
	28	67	113	125.5	M8x15	M8	41	28.5	6	19.5	22.5
	32	71	113	125.5	M8x15	M8	41	28.5	6	18.5	24.5
	35	73	113	125.5	M8x15	M8	50	37.5	11.25	26	26
	38	77.5	113	125.5	M8x15	M8	50	37.5	11.25	26	28
MP 160	14 -15.875 -16	48	130	142.5	M8x16	M6	40	27.5	6	20	14.5
	19	51	130	142.5	M8x16	M6	40	27.5	6	20	16.5
	22 -24	56.5	130	142.5	M8x16	M6	41	28.5	6	19.5	19
	28	67	130	142.5	M8x16	M8	41	28.5	6	19.5	22.5
	32	71	130	142.5	M8x16	M8	41	28.5	6	18.5	24.5
	35	73	130	142.5	M8x16	M8	50	37.5	11.25	26	26
	38	77.5	130	142.5	M8x16	M8	50	37.5	11.25	26	28
MP 190	14 -16	48	130	142.5	M8x14	M6	45.5	27.5	6	20	14.5
	19	51	130	142.5	M8x14	M6	45.5	27.5	6	20	16.5
	22 -24	56.5	130	142.5	M8x14	M6	47	29	6	20	19
	28	67	130	142.5	M8x14	M8	47	29	6	20	22.5
	32	71	130	142.5	M8x14	M8	47	29	6	20	24.5
	35	73	130	142.5	M8x14	M8	54.5	36.5	6	25	26
	38	77.5	130	142.5	M8x14	M8	54.5	36.5	6	25	28
	42	92	130	142.5	M8x14	M10	60.5	40	6	25	33
	45	95	130	142.5	M8x14	M10	60.5	40	6	25	33
48	97	130	142.5	M8x14	M10	60.5	40	6	25	33	

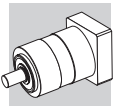

INDEX OF REVISIONS (R)

R1	
	DESCRIPTION
24 ... 35	Chapter 3 "Dimensions" - the dimensions and the availability of motor mounting flanges have been updated

100723

This publication supersedes and replaces any previous edition and revision. We reserve the right to implement modifications without notice. This catalogue cannot be reproduced, even partially, without prior consent.

MP



www.tecnoingranaggi.it

TECNOINGRANAGGI

TECNOINGRANAGGI RIDUTTORI s.r.l.
Via Davia, 5
40017 S. Giovanni in Persiceto
Bologna (ITALY)
Tel. (+39) 0516878111
Fax (+39) 0516878132
www.tecnoingranaggi.it
info@tecnoingranaggi.it