

# PENTA

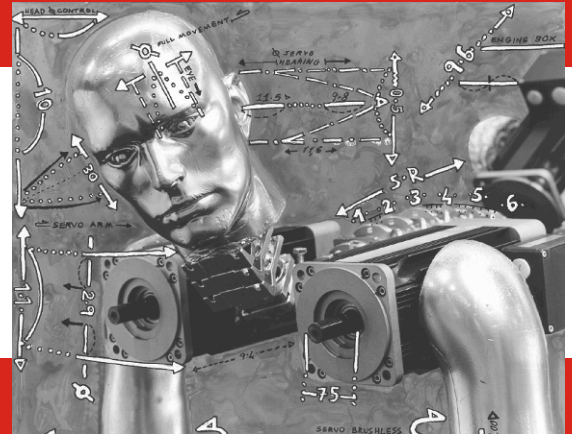

## D.C. MOTOR

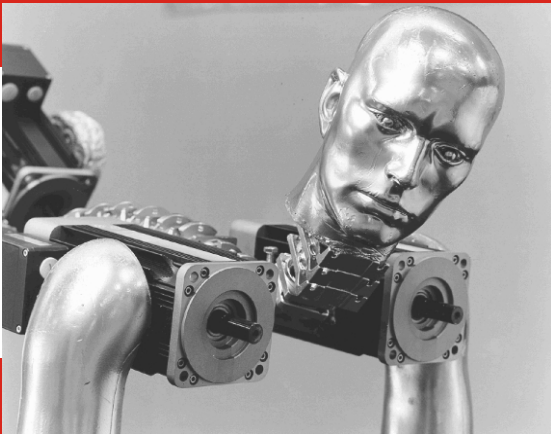

**MOTOR  
POWER  
COMPANY**

[www.motorpowergroup.com](http://www.motorpowergroup.com)

# PENTA

This direct current motors series, whose power range goes from 45 Watt to 1500Watt, was created after a careful market analysis and represents the right balance among performance-price-quality. Thanks to components such as copper-silver commutator, long-life brushes and ferrite permanent magnets, which are magnetized and calibrated in place, PENTA series assures a high performance competitiveness.

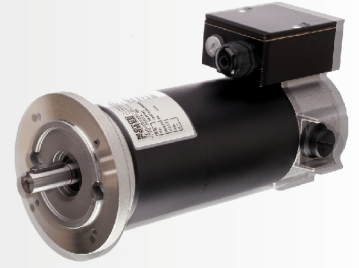

Motor Type	Power Watt		Rated Speed Torque (Nm)	Voltage (Vdc)	Mounting				Ventilation		Dimensions (mm)	
	3000 Rpm	2000 Rpm			B3	B5	B14	Natural	Fan Cooled	Diameter	Length	
PENTA 1S	45		0.14	24÷48						57.8	109.5	
PENTA 1M	70		0.22								136	
PENTA 1L	95		0.30								183.5	
PENTA 4S	300	200	0.95	12÷180						116	197.5	
PENTA 4M	600	400	1.9	24÷180							227.5	
PENTA 4L	900	600	2.86								257.5	
PENTA 5X	100	70	0.32	12÷180						83.5	144.5	
PENTA 5XS	150	100	0.48								177.5	
PENTA 5S	200	135	0.64								212.5	
PENTA 5SL	300	200	0.96	24÷180							229	
PENTA 5M	360	240	1.15	36÷180							267.5	
PENTA 5L	500	335	1.6	48÷180							322.5	
PENTA 5XA	150	100	0.48	12÷180						107	189.5	
PENTA 5XSA	235	155	0.75								222.5	
PENTA 5SA	300	200	0.96	24÷180							257.5	
PENTA 5SLA	440	290	1.4								274	
PENTA 5MA	565	375	1.8								312.5	
PENTA 7SA	750	500	2.4	90÷180						116	318	
PENTA 7MA	1100	750	3.5								390	
PENTA 7LA	1500	1100	4.8	110÷180							462	

- IP 54 protection
- Class F insulation
- Low noise
- High coercive ferrite permanent magnets field
- Skewed armature for higher linearity

SERIE  
Series

**PENTA 1S**

<b>W</b>	<b>RPM</b>
<b>45</b>	<b>3000</b>
	<b>2000</b>

**CARATTERISTICHE GENERALI - Performance characteristics**

TIPO MOTORE <i>Motor type</i>		1S 30																	
POTENZA RESA <i>Rated power</i>	Pnom [W]			45															
VELOCITA' NOMINALE <i>Rated speed</i>	Nnom [rpm]			3000											2000				
COPPIA NOMINALE <i>Rated torque</i>	Cnom [Nm]			0.143															
TENSIONE NOMINALE <i>Rated voltage</i>	Vnom [V]			48	36	24													
CORRENTE NOMINALE <i>Rated current</i>	Inom [A]			1.3	1.7	2.6													
COPPIA MASSIMA <i>Peak torque</i>	Cmax [Nm]			0.715	0.715	0.715													
CORRENTE MASSIMA <i>Peak current</i>	Imax [A]			6.5	8.5	13													
RESISTENZA ARMATURA <i>Armature resistance</i>	Rarm [Ohm]			6.3	3.33	1.33													
INDUTTANZA ARMATURA <i>Armature inductance</i>	La [mH]			9	4.95	2													
COST. TENSIONE <i>Voltage constant</i>	Ke [V/Krpm]			13	10	6.4													
COST. TEMPO ELET. <i>Elect.time constant</i>	Te [ms]			1.5	1.5	1.5													
COST. TEMPO MECC. <i>Mech.time constant</i>	Tm [ms]			6	5	5													

\* Solo per servizio intermittente - *Only intermittent duty*

**DATI MECCANICI - Mechanical data**

INERZIA ROTORE <i>Rotor inertia</i>	Jm [Kgcm <sup>2</sup> ]	0.15
MAX ACC. TEORICA <i>Max theor. Acc.</i>	[Rad/sec <sup>2</sup> ]	47000
CARICO RADIALE MAX <i>Max radial load</i>	RI [N]	196
CARICO ASSIALE MAX <i>Max axial load</i>	AI [N]	58
PESO MOTORE <i>Motor weight</i>	G [Kg]	0.95
VENTILAZIONE <i>Ventilation</i>		NATURALE T.E.N.V.
GRADO DI PROTEZIONE <i>Class protection</i>	IP	54

**DATI ELETTRICI - Winding data**

COST. DI TEMPO TERMICO <i>Thermal time constant</i>	Tt [min]	20
MAX VEL. SENZA CARICO <i>Max no load speed</i>	No max [rpm]	4000
MAX VEL. CON CARICO <i>Max load speed</i>	N max [rpm]	3000
CLASSE D'ISOLAMENTO <i>Insulation class</i>		F
FATTORE DI SERVIZIO <i>Duty cycle</i>		S1
FATTORE DI FORMA <i>Form factor</i>	FF	1
TEMP. AMBIENTE RIF. DATI <i>Room temp. data refer.</i>	T rif [°C]	40°

# MOTORI IN CORRENTE CONTINUA

## D.C. MOTORS

# MOTOR POWER COMPANY

SERIE  
Series

# PENTA

# 1M

<b>W</b>	<b>RPM</b>
<b>70</b>	<b>3000</b>
	<b>2000</b>

### CARATTERISTICHE GENERALI - Performance characteristics

TIPO MOTORE		1M30																		
Motor type		1M30																		
POTENZA RESA	P <sub>nom</sub>																			
Rated power	[W]			70																
VELOCITA' NOMINALE	N <sub>nom</sub>																			
Rated speed	[rpm]			3000																2000
COPPIA NOMINALE	C <sub>nom</sub>																			
Rated torque	[Nm]			0.22																
TENSIONE NOMINALE	V <sub>nom</sub>																			
Rated voltage	[V]			48	36	24														
CORRENTE NOMINALE	I <sub>nom</sub>																			
Rated current	[A]			1.95	2.6	3.65														
COPPIA MASSIMA	C <sub>max</sub>																			
Peak torque	[Nm]			1.1	1.1	1.1														
CORRENTE MASSIMA	I <sub>max</sub>																			
Peak current	[A]			9.75	13	18.25														
RESISTENZA ARMATURA	R <sub>arm</sub>																			
Armature resistance	[Ohm]			2.33	1.85	0.85														
INDUTTANZA ARMATURA	L <sub>a</sub>																			
Armature inductance	[mH]			4	3	1.34														
COST. TENSIONE	K <sub>e</sub>																			
Voltage constant	[V/Krpm]			13.2	10.4	7.3														
COST. TEMPO ELET.	T <sub>e</sub>																			
Elect.time constant	[ms]			1.7	1.62	1.58														
COST. TEMPO MECC.	T <sub>m</sub>																			
Mech.time constant	[ms]			6.5	6	6														

\* Solo per servizio intermittente - Only intermittent duty

### DATI MECCANICI - Mechanical data

INERZIA ROTORE	J <sub>m</sub>					
Rotor inertia	[Kgc <sup>2</sup> ]			0.324		
MAX ACC. TEORICA						
Max theor. Acc.	[Rad/sec <sup>2</sup> ]			33950		
CARICO RADIALE MAX	R <sub>I</sub>					
Max radial load	[N]			196		
CARICO ASSIALE MAX	A <sub>I</sub>					
Max axial load	[N]			58		
PESO MOTORE	G					
Motor weight	[Kg]			1.3		
VENTILAZIONE				NATURALE		
Ventilation				T.E.N.V.		
GRADO DI PROTEZIONE						
Class protection	IP			54		

### DATI ELETTRICI - Winding data

COST. DI TEMPO TERMICO	T <sub>t</sub>				
Thermal time constant	[min]			25	
MAX VEL. SENZA CARICO	No max				
Max no load speed	[rpm]			4000	
MAX VEL. CON CARICO	N max				
Max load speed	[rpm]			3000	
CLASSE D'ISOLAMENTO					
Insulation class				F	
FATTORE DI SERVIZIO					
Duty cycle				S1	
FATTORE DI FORMA					
Form factor	FF			1	
TEMP. AMBIENTE RIF. DATI	T <sub>rif</sub>				
Room temp. data refer.	[°C]			40°	

SERIE  
Series

**PENTA**

**1L**

<b>W</b>	<b>RPM</b>
<b>95</b>	<b>3000</b>
	<b>2000</b>

**CARATTERISTICHE GENERALI - Performance characteristics**

TIPO MOTORE <i>Motor type</i>		1L 30																			
POTENZA RESA <i>Rated power</i>	Pnom [W]		95																		
VELOCITA' NOMINALE <i>Rated speed</i>	Nnom [rpm]		3000																		
COPPIA NOMINALE <i>Rated torque</i>	Cnom [Nm]		0.3																		
TENSIONE NOMINALE <i>Rated voltage</i>	Vnom [V]		48	36	24																
CORRENTE NOMINALE <i>Rated current</i>	Inom [A]		2.5	3.4	4.9																
COPPIA MASSIMA <i>Peak torque</i>	Cmax [Nm]		1.5	1.5	1.5																
CORRENTE MASSIMA <i>Peak current</i>	Imax [A]		12.5	17	24.5																
RESISTENZA ARMATURA <i>Armature resistance</i>	Rarm [Ohm]		2.43	1.19	0.48																
INDUTTANZA ARMATURA <i>Armature inductance</i>	La [mH]		3	1.65	0.7																
COST. TENSIONE <i>Voltage constant</i>	Ke [V/Krpm]		13.3	10.7	7.5																
COST. TEMPO ELET. <i>Elect.time constant</i>	Te [ms]		1.24	1.4	1.46																
COST. TEMPO MECC. <i>Mech.time constant</i>	Tm [ms]		9	7	6																

\* Solo per servizio intermittente - *Only intermittent duty*

**DATI MECCANICI - Mechanical data**

INERZIA ROTORE <i>Rotor inertia</i>	Jm [Kgcm <sup>2</sup> ]	0.607
MAX ACC. TEORICA <i>Max theor. Acc.</i>	[Rad/sec <sup>2</sup> ]	24711
CARICO RADIALE MAX <i>Max radial load</i>	RI [N]	196
CARICO ASSIALE MAX <i>Max axial load</i>	AI [N]	58
PESO MOTORE <i>Motor weight</i>	G [Kg]	1,85
VENTILAZIONE <i>Ventilation</i>		NATURALE T.E.N.V.
GRADO DI PROTEZIONE <i>Class protection</i>	IP	54

**DATI ELETTRICI - Winding data**

COST. DI TEMPO TERMICO <i>Thermal time constant</i>	Tt [min]	30
MAX VEL. SENZA CARICO <i>Max no load speed</i>	No max [rpm]	4000
MAX VEL. CON CARICO <i>Max load speed</i>	N max [rpm]	3000
CLASSE D'ISOLAMENTO <i>Insulation class</i>		F
FATTORE DI SERVIZIO <i>Duty cycle</i>		S1
FATTORE DI FORMA <i>Form factor</i>	FF	1
TEMP. AMBIENTE RIF. DATI <i>Room temp. data refer.</i>	T rif [°C]	40°

# PENTA 1

MOTORI C.C.

D.C. MOTORS



**DIMENSIONI (mm) DIMENSIONS (mm)**

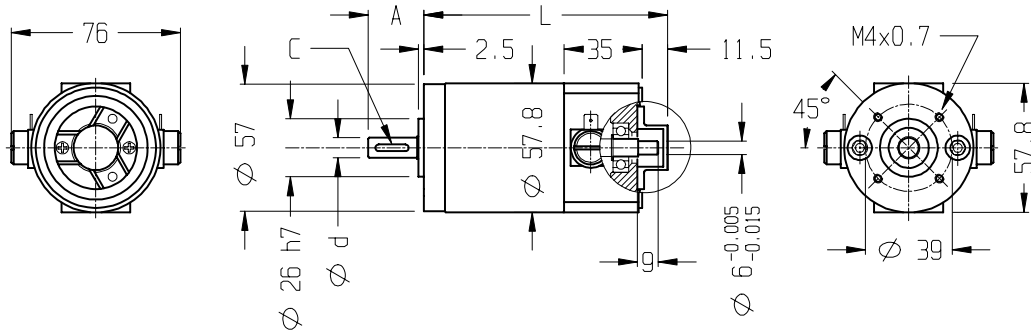

Type	S	M	L
A	20		25
L	109.5	136	183.5
d (j6)	7		9
C	-		3x3x15

## MORSETTIERA

## TERMINAL BOX

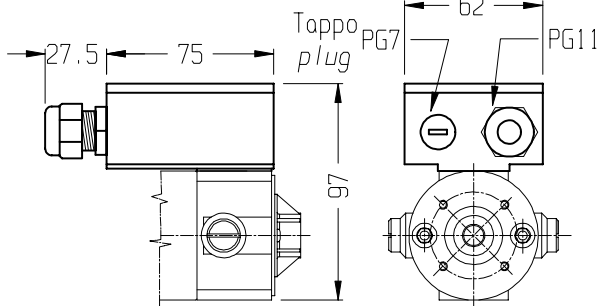

## CONNETTORE

## CONNECTOR

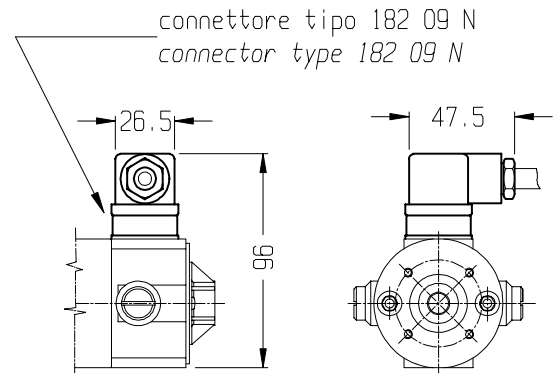

## CAVO

## FLYING LEADS

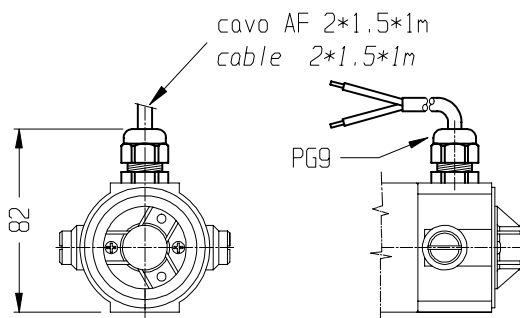

## FLANGIA B14/56

## B14/56 FLANGE

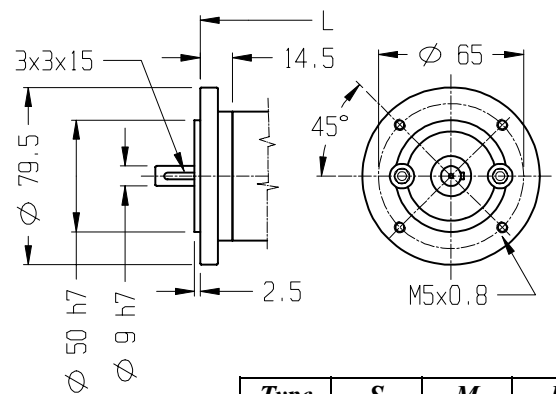

Type	S	M	L
L	114.5	141	188.5

## OPTIONALS

**PIEDE A FASCIA**

*FOOT BAND TYPE*

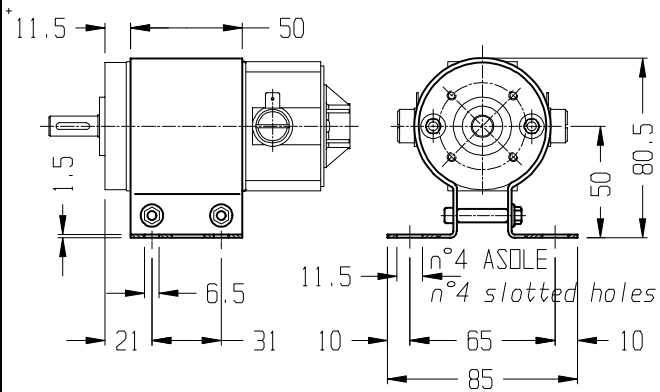

**PRED. ENCODER**

*ENC. PREARRANGEMENT*

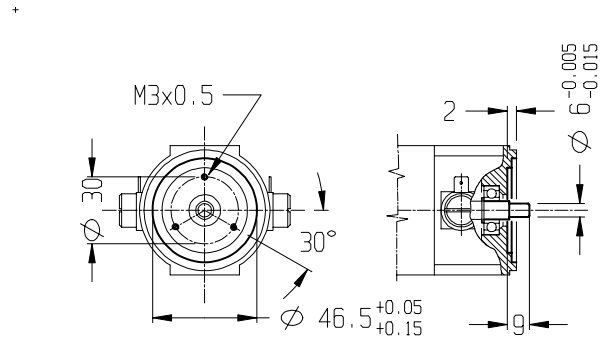

**ENCODER EH53**

*EH53 ENCODER*

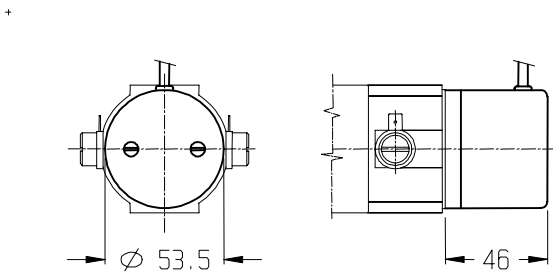

**ENCODER EH38**

*EH38 ENCODER*

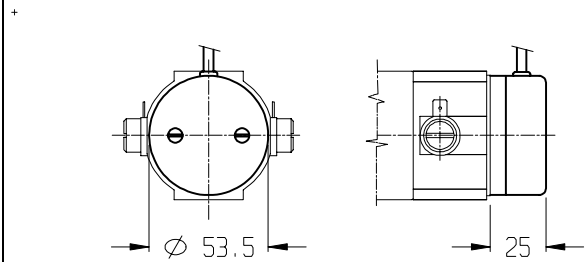

**DISTANZ. ENC. N°1**

*ENCODER SPACER N°1*

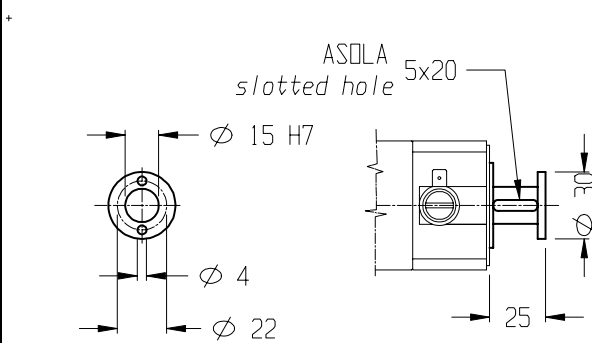

**DISTANZ. ENC. N°2**

*ENCODER SPACER N°2*

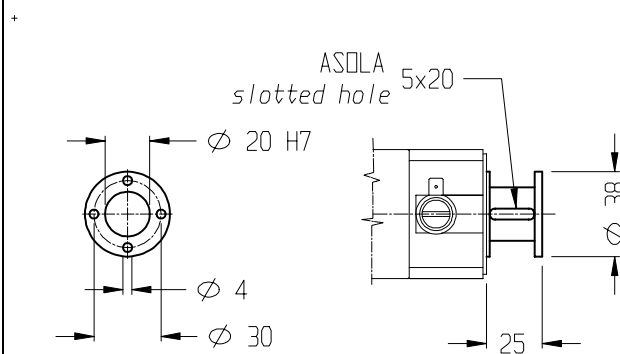

## OPTIONALS

### DIN. TACHIMETRICA TACHO GENERATOR

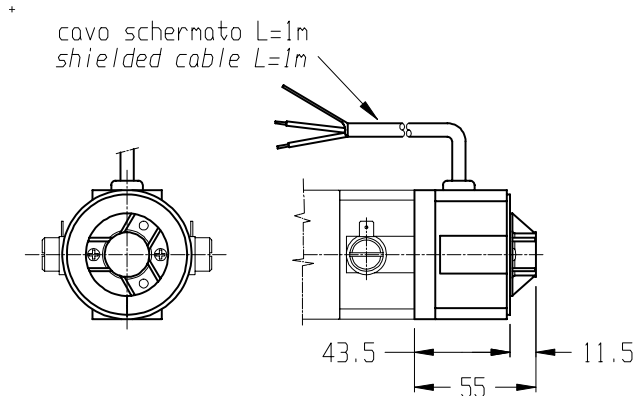

**PREDISPOSTO ENCODER ENCODER PREARRANGEMENT**

<b>COSTANTE DI TENSIONE</b> VOLTAGE CONSTANT	10±5% V/KRPM	<b>CORRENTE NOMINALE</b> RATED CURRENT	2 mA
<b>VELOCITA' MASSIMA</b> MAX SPEED	9000 RPM	<b>CORRENTE MASSIMA</b> MAX CURRENT	8 mA

### FRENO 0.5 Nm BRAKE 0.5 Nm

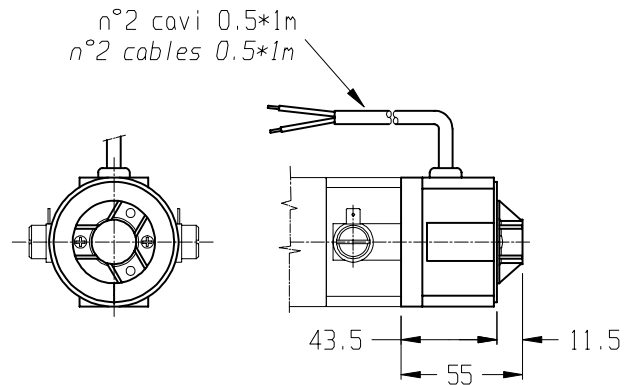

**PREDISPOSTO ENCODER ENCODER PREARRANGEMENT**

<b>COPPIA STATICA</b> STATIC TORQUE	0.5 Nm	<b>CORRENTE</b> CURRENT	0.42 A
<b>TENSIONE DI ALIMEN.</b> POWER SUPPLY VOLTAGE	24 V.c.c.	<b>POTENZA ASSORBITA</b> INPUT POWER	10 W

### FRENO 0.5 Nm + DIN. TACHO GENERATOR + TACHIMETRICA BRAKE 0.5 Nm

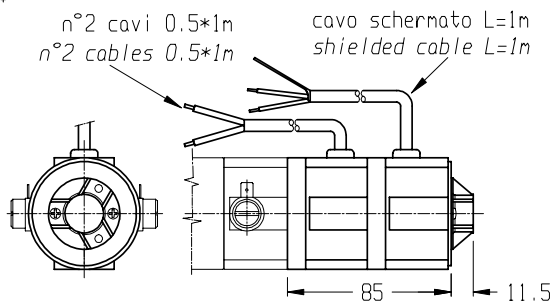

**PREDISPOSTO ENCODER ENCODER PREARRANGEMENT**

	FRENO BRAKE	DINAMO T. TACHO G.	
<b>COPPIA STATICA</b> STATIC TORQUE	0.5 Nm	<b>COSTANTE DI TENSIONE</b> VOLTAGE CONSTANT	10±5% V/KRPM
<b>TENSIONE DI ALIMEN.</b> POWER SUPPLY VOLTAGE	24 V.c.c.	<b>VELOCITA' MASSIMA</b> MAX SPEED	9000 RPM
<b>CORRENTE</b> CURRENT	0.42 A	<b>CORRENTE NOMINALE</b> RATED CURRENT	2 mA
<b>POTENZA ASSORBITA</b> INPUT POWER	10 W	<b>CORRENTE MASSIMA</b> MAX CURRENT	8 mA

SERIE  
Series

# PENTA 4S

<b>W</b>	<b>RPM</b>
<b>300</b>	<b>3000</b>
<b>200</b>	<b>2000</b>

## CARATTERISTICHE GENERALI - Performance characteristics

TIPO MOTORE	4S 30								4S20								
Motor type	4S 30								4S20								
POTENZA RESA	P <sub>nom</sub>																
Rated power	[W]	300								200							
VELOCITA' NOMINALE	N <sub>nom</sub>																
Rated speed	[rpm]	3000								2000							
COPPIA NOMINALE	C <sub>nom</sub>																
Rated torque	[Nm]	0.95								0.95							
TENSIONE NOMINALE	V <sub>nom</sub>																
Rated voltage	[V]	180	90	60	48	36	24	12	180	90	60	48	36	24	12		
CORRENTE NOMINALE	I <sub>nom</sub>																
Rated current	[A]	2.22	4.44	6.67	8.33	11.11	16.67	33.33	1.48	2.96	4.44	5.56	7.41	11.11	22.22		
COPPIA MASSIMA	C <sub>max</sub>																
Peak torque	[Nm]	4.76								4.76							
CORRENTE MASSIMA	I <sub>max</sub>																
Peak current	[A]	11.1	22.2	33.3	41.7	55.6	83.3	166.7	7.4	14.8	22.2	27.8	37.0	55.6	111.1		
RESISTENZA ARMATURA	R <sub>arm</sub>																
Armature resistance	[Ohm]	7.36	1.91	1.19	0.91	0.62	0.23	0.09	16.99	3.66	1.94	1.92	1.20	0.47	0.16		
INDUTTANZA ARMATURA	La																
Armature inductance	[mH]	30.00	7.50	3.59	0.90	0.51	0.23	0.06	80.00	19.50	8.67	2.05	1.12	0.51	0.14		
COST. TENSIONE	Ke																
Voltage constant	[V/Krpm]	54.5	27.3	18.2	14.5	10.6	7.1	3.5	81.8	40.9	27.3	21.8	15.9	10.6	5.2		
COST. TEMPO ELET.	Te																
Elect.time constant	[ms]	4.08	3.93	3.02	0.99	0.81	0.98	0.59	4.71	5.32	4.47	1.07	0.93	1.09	0.88		
COST. TEMPO MECC.	Tm																
Mech.time constant	[ms]	31.2	32.3	45.4	54.4	69.8	58.1	98.9	32.0	27.6	32.9	50.8	60.1	53.0	74.3		

\* Solo per servizio intermittente - Intermittent duty only

## DATI MECCANICI - Mechanical data

INERZIA ROTORE	Jm	
Rotor inertia	[Kgm <sup>2</sup> ]	0.00115
MAX ACC. TEORICA		
Max theor. Acc.	[Rad/sec <sup>2</sup> ]	4141
CARICO RADIALE MAX	RI	
Max radial load	[N]	360
CARICO ASSIALE MAX	AI	
Max axial load	[N]	108
PESO MOTORE	G	
Motor weight	[Kg]	5.3
VENTILAZIONE		NATURALE
Ventilation		T.E.N.V.
GRADO DI PROTEZIONE		
Class protection	IP	54

## DATI ELETTRICI - Winding data

COST. DI TEMPO TERMICO	Tt	
Thermal time constant	[min]	30
MAX VEL. SENZA CARICO	No max	
Max no load speed	[rpm]	4000
MAX VEL. CON CARICO	N max	
Max load speed	[rpm]	3000
CLASSE D'ISOLAMENTO		
Insulation class		F
FATTORE DI SERVIZIO		
Duty cycle		S1
FATTORE DI FORMA		
Form factor	FF	1
TEMP. AMBIENTE RIF. DATI	T rif	
Room temp. data refer.	[°C]	40°

SERIE  
Series

# PENTA 4M

W	RPM
600	3000
400	2000

## CARATTERISTICHE GENERALI - Performance characteristics

TIPO MOTORE	4M 30								4M20								
Motor type	4M 30								4M20								
POTENZA RESA	P <sub>nom</sub>																
Rated power	[W]	600								400							
VELOCITA' NOMINALE	N <sub>nom</sub>																
Rated speed	[rpm]	3000								2000							
COPPIA NOMINALE	C <sub>nom</sub>																
Rated torque	[Nm]	1.90								1.90							
TENSIONE NOMINALE	V <sub>nom</sub>																
Rated voltage	[V]	180	90	60	48	36	24	12*	180	90	60	48	36	24	12*		
CORRENTE NOMINALE	I <sub>nom</sub>																
Rated current	[A]	4.44	8.89	13.33	16.67	22.22	33.33	66.67	2.96	5.93	8.89	11.11	14.81	22.22	44.44		
COPPIA MASSIMA	C <sub>max</sub>																
Peak torque	[Nm]	9.52								9.52							
CORRENTE MASSIMA	I <sub>max</sub>																
Peak current	[A]	22.2	44.4	66.7	83.3	111.1	166.7	333.3	14.8	29.6	44.4	55.6	74.1	111.1	222.2		
RESISTENZA ARMATURA	R <sub>arm</sub>																
Armature resistance	[Ohm]	2.84	0.96	0.59	0.52	0.40	0.13	0.08	4.79	1.62	0.81	0.95	0.54	0.23	0.11		
INDUTTANZA ARMATURA	L <sub>a</sub>																
Armature inductance	[mH]	12.80	2.98	1.23	0.45	0.28	0.11	0.02	27.00	6.75	3.00	1.05	0.54	0.24	0.06		
COST. TENSIONE	K <sub>e</sub>																
Voltage constant	[V/Krpm]	56.3	27.3	18.2	14.5	10.6	7.1	3.5	81.8	40.9	27.3	21.8	15.9	10.6	5.2		
COST. TEMPO ELET.	T <sub>e</sub>																
Elect.time constant	[ms]	4.50	3.12	2.09	0.87	0.70	0.87	0.25	5.64	4.16	3.72	1.10	0.99	1.04	0.56		
COST. TEMPO MECC.	T <sub>m</sub>																
Mech.time constant	[ms]	20.2	28.9	40.2	55.3	79.4	58.6	156.6	16.1	21.8	24.4	44.9	48.4	45.8	88.5		

\* Solo per servizio intermittente - Intermittent duty only

## DATI MECCANICI - Mechanical data

INERZIA ROTORE	J <sub>m</sub>	
Rotor inertia	[Kgm <sup>2</sup> ]	0.00205
MAX ACC. TEORICA		
Max theor. Acc.	[Rad/sec <sup>2</sup> ]	4646
CARICO RADIALE MAX	R <sub>I</sub>	
Max radial load	[N]	360
CARICO ASSIALE MAX	A <sub>I</sub>	
Max axial load	[N]	108
PESO MOTORE	G	
Motor weight	[Kg]	6,8
VENTILAZIONE		NATURALE
Ventilation		T.E.N.V.
GRADO DI PROTEZIONE		
Class protection	IP	54

## DATI ELETTRICI - Winding data

COST. DI TEMPO TERMICO	T <sub>t</sub>	
Thermal time constant	[min]	40
MAX VEL. SENZA CARICO	No max	
Max no load speed	[rpm]	4000
MAX VEL. CON CARICO	N max	
Max load speed	[rpm]	3000
CLASSE D'ISOLAMENTO		
Insulation class		F
FATTORE DI SERVIZIO		
Duty cycle		S1
FATTORE DI FORMA		
Form factor	FF	1
TEMP. AMBIENTE RIF. DATI	T <sub>rif</sub>	
Room temp. data refer.	[°C]	40°

SERIE  
Series

# PENTA 4L

<b>W</b>	<b>RPM</b>
<b>900</b>	<b>3000</b>
<b>600</b>	<b>2000</b>

## CARATTERISTICHE GENERALI - Performance characteristics

TIPO MOTORE	4L 30								4L20								
Motor type	4L 30								4L20								
POTENZA RESA	P <sub>nom</sub>																
Rated power	[W]	900								600							
VELOCITA' NOMINALE	N <sub>nom</sub>																
Rated speed	[rpm]	3000								2000							
COPPIA NOMINALE	C <sub>nom</sub>																
Rated torque	[Nm]	2.86								2.86							
TENSIONE NOMINALE	V <sub>nom</sub>																
Rated voltage	[V]	180	90	60	48	36	24*	12*	180	90	60	48	36	24	12*		
CORRENTE NOMINALE	I <sub>nom</sub>																
Rated current	[A]	6.67	13.33	20.00	25.00	33.33	50.00	100.00	4.44	8.89	13.33	16.67	22.22	33.33	66.67		
COPPIA MASSIMA	C <sub>max</sub>																
Peak torque	[Nm]	14.29								14.29							
CORRENTE MASSIMA	I <sub>max</sub>																
Peak current	[A]	33.3	66.7	100.00	125.0	166.7	250.0	500.0	22.2	44.4	66.7	83.3	111.1	166.7	333.3		
RESISTENZA ARMATURA	R <sub>arm</sub>																
Armature resistance	[Ohm]	1.73	0.69	0.45	0.36	0.28	0.11	0.07	2.50	0.85	0.49	0.53	0.36	0.13	0.09		
INDUTTANZA ARMATURA	L <sub>a</sub>																
Armature inductance	[mH]	7.50	1.88	0.35	0.25	0.12	0.06	0.01	12.70	3.18	1.52	0.48	0.24	0.12	0.02		
COST. TENSIONE	K <sub>e</sub>																
Voltage constant	[V/Krpm]	57.1	27.3	18.2	14.5	10.6	7.1	3.5	81.8	40.9	27.3	21.8	15.9	10.6	5.2		
COST. TEMPO ELET.	T <sub>e</sub>																
Elect.time constant	[ms]	4.34	2.70	0.78	0.67	0.42	0.56	0.13	5.08	3.75	3.08	0.90	0.67	0.90	0.26		
COST. TEMPO MECC.	T <sub>m</sub>																
Mech.time constant	[ms]	16.8	29.7	43.5	54.7	80.2	69.6	193.6	11.9	16.1	21.1	35.5	45.8	37.7	99.9		

\* Solo per servizio intermittente - Intermittent duty only

## DATI MECCANICI - Mechanical data

INERZIA ROTORE	J <sub>m</sub>	
Rotor inertia	[Kgm <sup>2</sup> ]	0.0029
MAX ACC. TEORICA		
Max theor. Acc.	[Rad/sec <sup>2</sup> ]	4946
CARICO RADIALE MAX	R <sub>I</sub>	
Max radial load	[N]	360
CARICO ASSIALE MAX	A <sub>I</sub>	
Max axial load	[N]	108
PESO MOTORE	G	
Motor weight	[Kg]	8,3
VENTILAZIONE		NATURALE
Ventilation		T.E.N.V.
GRADO DI PROTEZIONE		
Class protection	IP	54

## DATI ELETTRICI - Winding data

COST. DI TEMPO TERMICO	T <sub>t</sub>	
Thermal time constant	[min]	60
MAX VEL. SENZA CARICO	No max	
Max no load speed	[rpm]	4000
MAX VEL. CON CARICO	N max	
Max load speed	[rpm]	3000
CLASSE D'ISOLAMENTO		
Insulation class		F
FATTORE DI SERVIZIO		
Duty cycle		S1
FATTORE DI FORMA		
Form factor	FF	1
TEMP. AMBIENTE RIF. DATI	T <sub>rif</sub>	
Room temp. data refer.	[°C]	40°

# PENTA 4

MOTORI C.C.

D.C. MOTORS



DIMENSIONI (mm) DIMENSIONS (mm)

## PIEDE

## FOOT

Type	S	M	L
L	197.5	227.5	257.5

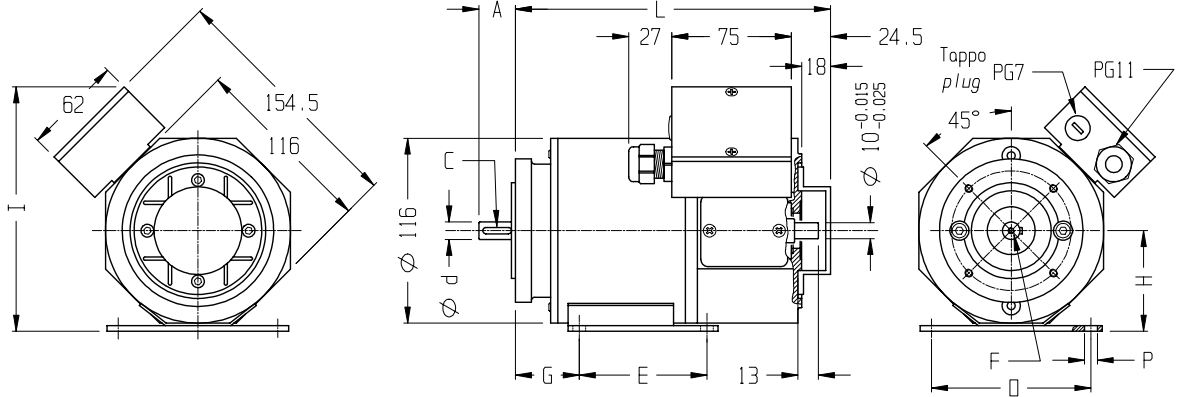

Size	A	C	d(h7)	E	F	G	H	I	O	P
63	23	4x4x18	11	80	M4	40	63	153	100	8
71	30	5x5x25	14	90	M5	45	71	161	112	9

## FLANGIA B14

## B14 FLANGE

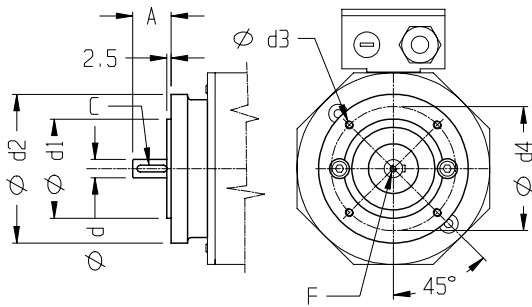

Size	A	C	d(h7)	d1(h7)	d2	d3	d4	F
56	20	3x3x15	9	50	80	M5	65	-
63	23	4x4x18	11	60	90	M5	75	M4
71	30	5x5x25	14	70	105	M6	85	M5

## FLANGIA B5

## B5 FLANGE

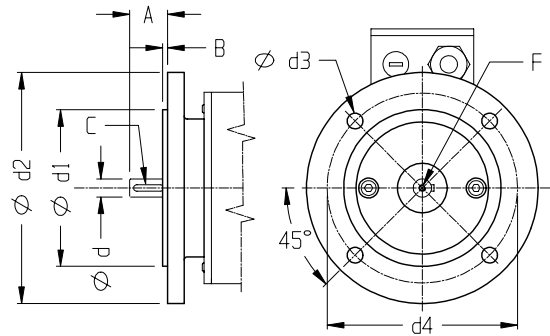

Size	A	B	C	d(h7)	d1(h7)	d2	d3	d4	F
56	20	3	3x3x15	9	80	120	8.5	100	-
63	23	3	4x4x18	11	95	140	9.5	115	M4
71	30	3.5	5x5x25	14	110	160	9.5	130	M5

## CONNETTORE

## CONNECTOR

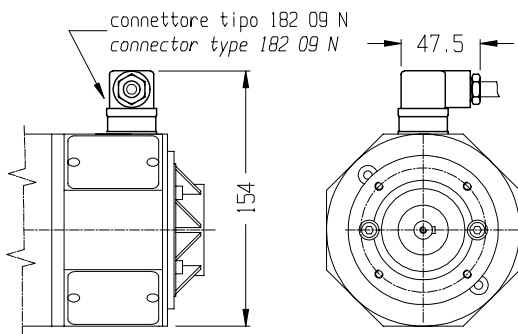

## CAVO

## FLYING LEADS

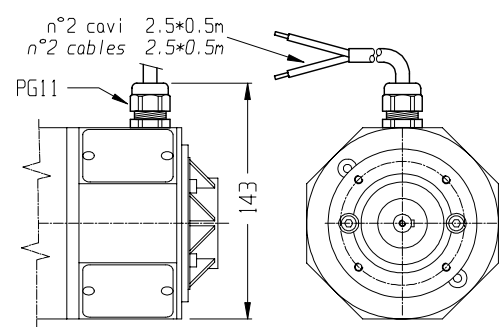

# PENTA 4

MOTORI C.C.

D.C. MOTORS



## OPTIONALS

**PRED. ENCODER**      *ENC. PREARRANGEMENT*

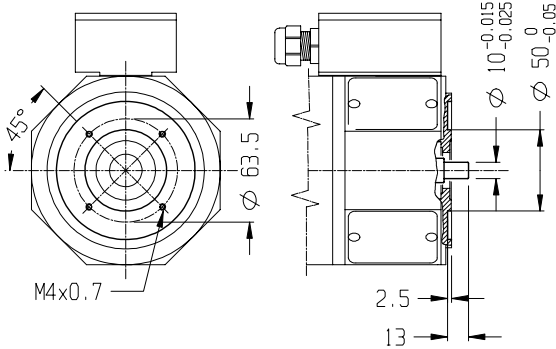

**ENCODER EL72**

*EL72 ENCODER*

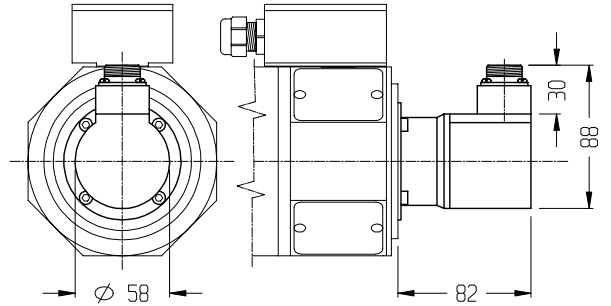

**DISTANZ. ENC. N°1**

*ENC. SPACER N°1*

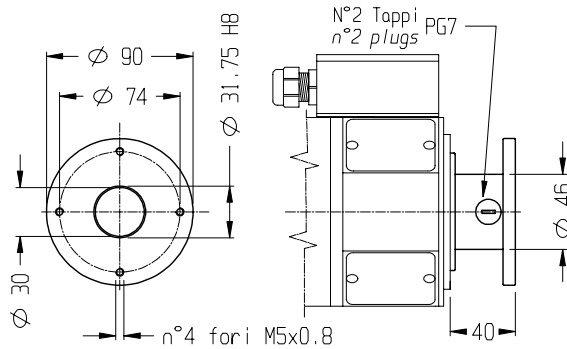

**DIN. TACHIMETRICA**

*TACHO GENERATOR*

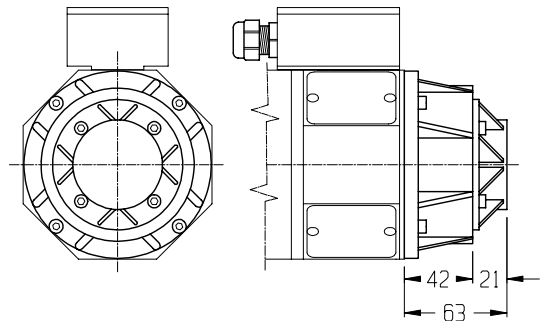

<b>COSTANTE DI TENSIONE</b> <i>VOLTAGE CONSTANT</i>	10±5% V/KRPM	<b>CORRENTE NOMINALE</b> <i>RATED CURRENT</i>	2 mA
<b>VELOCITA' MASSIMA</b> <i>MAX SPEED</i>	9000 RPM	<b>CORRENTE MASSIMA</b> <i>MAX CURRENT</i>	8 mA

**FRENO N°1: 1,7 Nm**

*BRAKE N°1: 1,7 Nm*

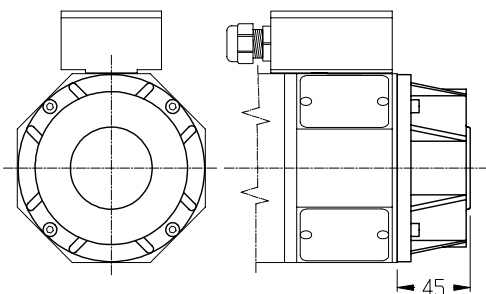

<b>COPPIA STATICA</b> <i>STATIC TORQUE</i>	1,7 Nm	<b>CORRENTE</b> <i>CURRENT</i>	0.46-0.058 A
<b>TENSIONE DI ALIMEN.</b> <i>POWER SUPPLY VOLTAGE</i>	24-190 V.c.c.	<b>POTENZA ASSORBITA</b> <i>INPUT POWER</i>	11 W

**FRENO N°2: 4 Nm**

*BRAKE N°2: 4 Nm*

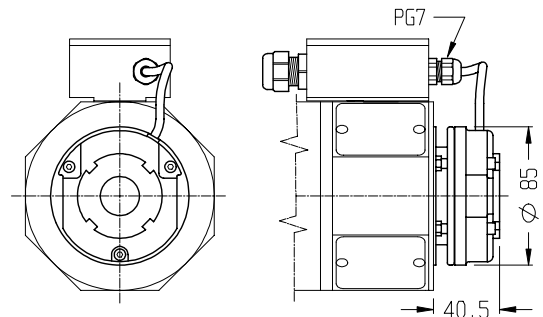

<b>COPPIA STATICA</b> <i>STATIC TORQUE</i>	4 Nm	<b>CORRENTE</b> <i>CURRENT</i>	0.83-0.109 A
<b>TENSIONE DI ALIMEN.</b> <i>POWER SUPPLY VOLTAGE</i>	24-190 V.c.c.	<b>POTENZA ASSORBITA</b> <i>INPUT POWER</i>	20 W

SERIE  
Series

**PENTA 5X**

<b>W</b>	<b>RPM</b>
<b>100</b>	<b>3000</b>
<b>70</b>	<b>2000</b>

**CARATTERISTICHE GENERALI - Performance characteristics**

TIPO MOTORE		5X 30								5X20							
MOTOR type																	
POTENZA RESA	Pnom																
Rated power	[W]	100								70							
VELOCITA' NOMINALE	Nnom																
Rated speed	[rpm]	3000								2000							
COPPIA NOMINALE	Cnom																
Rated torque	[Nm]	0.32								0.32							
TENSIONE NOMINALE	Vnom																
Rated voltage	[V]	180	90	60	48	36	24	12	180	90	60	48	33	24	12		
CORRENTE NOMINALE	Inom																
Rated current	[A]	0.74	1.5	2.2	2.8		5.54	11	0.55	1.1	1.6	2	2.8	4	8		
COPPIA MASSIMA	Cmax																
Peak torque	[Nm]	1.6	1.6	1.6	1.6		1.6	1.6	1.6	1.6	1.6	1.6	1.6	1.6	1.6		
CORRENTE MASSIMA	Imax																
Peak current	[A]	3.7	7.5	11	14		27.7	55	2.75		8	10	14	20	40		
RESISTENZA ARMATURA	Rarm																
Armature resistance	[Ohm]	16.7	4.1	1.8	1.28		0.4	0.12	41.1		4.1	2.4	1.28	0.86	0.25		
INDUTTANZA ARMATURA	La																
Armature inductance	[mH]	46.5	10.25	4.15	2.95		0.8	0.19	135	35.4	10.25	5.75	2.95	1.75	0.5		
COST. TENSIONE	Ke																
Voltage constant	[V/Krpm]	54	27	17	15		7	3.4	82	40	26	20	15	9.6	5		
COST. TEMPO ELET.	Te																
Elect.time constant	[ms]	2.8	2.5	2.3	2.3		2	1.6	3.3		2.5	2.4	2.3	2.1	1.6		
COST. TEMPO MECC.	Tm																
Mech.time constant	[ms]	11	11	12	11		16	20	12		11	12	11	15	19		

\* Solo per servizio intermittente - Only intermittent duty

**DATI MECCANICI - Mechanical data**

INERZIA ROTORE	Jm	
Rotor inertia	[Kgm <sup>2</sup> ]	0.00018
MAX ACC. TEORICA		
Max theor. Acc.	[Rad/sec <sup>2</sup> ]	8800
CARICO RADIALE MAX	RI	
Max radial load	[N]	294
CARICO ASSIALE MAX	AI	
Max axial load	[N]	88
PESO MOTORE	G	
Motor weight	[Kg]	2.9
VENTILAZIONE		NATURALE
Ventilation		T.E.N.V.
GRADO DI PROTEZIONE		
Class protection	IP	54

**DATI ELETTRICI - Winding data**

COST. DI TEMPO TERMICO	Tt	
Thermal time constant	[min]	20
MAX VEL. SENZA CARICO	No max	
Max no load speed	[rpm]	4000
MAX VEL. CON CARICO	N max	
Max load speed	[rpm]	3000
CLASSE D'ISOLAMENTO		
Insulation class		F
FATTORE DI SERVIZIO		
Duty cycle		S1
FATTORE DI FORMA		
Form factor	FF	1
TEMP. AMBIENTE RIF. DATI	T rif	
Room temp. data refer.	[°C]	40°

# MOTORI IN CORRENTE CONTINUA

## D.C. MOTORS



SERIE  
Series

# PENTA 5XS

W	RPM
150	3000
100	2000

### CARATTERISTICHE GENERALI - Performance characteristics

TIPO MOTORE	5XS 30								5XS 20								
Motor type																	
POTENZA RESA Rated power	Pnom [W]	150								100							
VELOCITA' NOMINALE Rated speed	Nnom [rpm]	3000								2000							
COPPIA NOMINALE Rated torque	Cnom [Nm]	0.48								0.48							
TENSIONE NOMINALE Rated voltage	Vnom [V]	180	90	60	48	36	24	12	180	90	60	48	36	24	12		
CORRENTE NOMINALE Rated current	Inom [A]	1.1	2.2	3.3	4.2	5.55	8.33	16	0.74	1.5	2.2	2.8	3.7	5.54	11		
COPPIA MASSIMA Peak torque	Cmax [Nm]	2.4	2.4	2.4	2.4	2.4	2.4	2.4	2.4	2.4	2.4	2.4		2.4	2.4		
CORRENTE MASSIMA Peak current	Imax [A]	5.5		16.7	21		41.7	80	3.7		11	14		27.7	55		
RESISTENZA ARMATURA Armature resistance	Rarm [Ohm]	13.9	4.04	1.64	1.1		0.29	0.12	26.9		3.5	2.6		0.54	0.184		
INDUTTANZA ARMATURA Armature inductance	La [mH]	47	11	5.4	3.5	1.92	0.73	0.165	100	29	10.9	7.5	4.7	1.3	2.2		
COST. TENSIONE Voltage constant	Ke [V/Krpm]	54		18	15		7	3.4	82		26	20		9.6	5		
COST. TEMPO ELET. Elect.time constant	Te [ms]	3.4	3.2	3.29	3.2	3.5	2.5	1.4	3.7	3.5	3.2	2.9	3.4	2.4	2.2		
COST. TEMPO MECC. Mech.time constant	Tm [ms]	15		17	16		19	34	13		17	21		19	24		

\* Solo per servizio intermittente - Only intermittent duty

### DATI MECCANICI - Mechanical data

INERZIA ROTORE Rotor inertia	Jm [Kgm <sup>2</sup> ]	0.0003
MAX ACC. TEORICA Max theor. Acc.	[Rad/sec <sup>2</sup> ]	8000
CARICO RADIALE MAX Max radial load	RI [N]	294
CARICO ASSIALE MAX Max axial load	AI [N]	88
PESO MOTORE Motor weight	G [Kg]	3.5
VENTILAZIONE Ventilation	NATURALE T.E.N.V.	
GRADO DI PROTEZIONE Class protection	IP	54

### DATI ELETTRICI - Winding data

COST. DI TEMPO TERMICO Thermal time constant	Tt [min]	25
MAX VEL. SENZA CARICO Max no load speed	No max [rpm]	4000
MAX VEL. CON CARICO Max load speed	N max [rpm]	3000
CLASSE D'ISOLAMENTO Insulation class	F	
FATTORE DI SERVIZIO Duty cycle	S1	
FATTORE DI FORMA Form factor	FF	1
TEMP. AMBIENTE RIF. DATI Room temp. data refer.	T rif [°C]	40°

SERIE  
Series

**PENTA 5S**

<b>W</b>	<b>RPM</b>
<b>200</b>	<b>3000</b>
<b>135</b>	<b>2000</b>

**CARATTERISTICHE GENERALI - Performance characteristics**

TIPO MOTORE	5S 30								5S 20								
Motor type	5S 30								5S 20								
POTENZA RESA Rated power	Pnom [W]	200								135							
VELOCITA' NOMINALE Rated speed	Nnom [rpm]	3000								2000							
COPPIA NOMINALE Rated torque	Cnom [Nm]	0.64								0.64							
TENSIONE NOMINALE Rated voltage	Vnom [V]	180	90	60	48	36	24	12*	180	88	60	46	36	24	12		
CORRENTE NOMINALE Rated current	Inom [A]	1.4	2.85	4.3	5.3	7	10.7		0.97	2.1	2.9	3.8	4.8	7.25	14.5		
COPPIA MASSIMA Peak torque	Cmax [Nm]	3.2	3.2	3.2	3.2	3.2	3.2		3.2	3.2	3.2	3.2	3.2	3.2	3.2		
CORRENTE MASSIMA Peak current	Imax [A]	7		21.5	26.5		53.5		4.85	10.5	14.5	19		36	72.5		
RESISTENZA ARMATURA Armature resistance	Rarm [Ohm]	6.15		0.92	0.6		0.17		15.5	3	1.36	0.96	1.08	0.33	0.12		
INDUTTANZA ARMATURA Armature inductance	La [mH]	20	5.79	2.5	1.5	0.76	0.32		49	11	3.9	2.67	1.77	0.73	0.16		
COST. TENSIONE Voltage constant	Ke [V/Krpm]	54	28.5	18	15		7		82	40	26	20	16.6	9.6	5		
COST. TEMPO ELET. Elect.time constant	Te [ms]	3.3	3.33	2.7	2.5		1.9		3.2	3.7	2.9	2.8		2.2	1.7		
COST. TEMPO MECC. Mech.time constant	Tm [ms]	14		19	17		23		15	12	13	16		21	31		

\* Solo per servizio intermittente - Only intermittent duty

**DATI MECCANICI - Mechanical data**

INERZIA ROTORE Rotor inertia	Jm [Kgm <sup>2</sup> ]	0.0006
MAX ACC. TEORICA Max theor. Acc.	[Rad/sec <sup>2</sup> ]	5330
CARICO RADIALE MAX Max radial load	RI [N]	294
CARICO ASSIALE MAX Max axial load	AI [N]	88
PESO MOTORE Motor weight	G [Kg]	4.6
VENTILAZIONE Ventilation	NATURALE T.E.N.V.	
GRADO DI PROTEZIONE Class protection	IP	54

**DATI ELETTRICI - Winding data**

COST. DI TEMPO TERMICO Thermal time constant	Tt [min]	30
MAX VEL. SENZA CARICO Max no load speed	No max [rpm]	4000
MAX VEL. CON CARICO Max load speed	N max [rpm]	3000
CLASSE D'ISOLAMENTO Insulation class	F	
FATTORE DI SERVIZIO Duty cycle	S1	
FATTORE DI FORMA Form factor	FF	1
TEMP. AMBIENTE RIF. DATI Room temp. data refer.	T rif [°C]	40°

SERIE  
Series

**PENTA 5SL**

<b>W</b>	<b>RPM</b>
<b>300</b>	<b>3000</b>
<b>200</b>	<b>2000</b>

**CARATTERISTICHE GENERALI - Performance characteristics**

TIPO MOTORE	5SL 30								5SL 20									
Motor type																		
POTENZA RESA	Pnom																	
Rated power	[W]		300								200							
VELOCITA' NOMINALE	Nnom																	
Rated speed	[rpm]		3000								2000							
COPPIA NOMINALE	Cnom																	
Rated torque	[Nm]		0.96								0.96							
TENSIONE NOMINALE	Vnom																	
Rated voltage	[V]		180	90	60	48	36	24	12*	180	90	60	48	36	24	12*		
CORRENTE NOMINALE	Inom																	
Rated current	[A]		2.1	4.2	6.3	7.8	10.4	15.6		1.4	2.8	4.2	5.2	7	10.4			
COPPIA MASSIMA	Cmax																	
Peak torque	[Nm]		4.8	4.8	4.8	4.8	4.8	4.8		4.8	4.8	4.8	4.8	4.8	4.8			
CORRENTE MASSIMA	Imax																	
Peak current	[A]		10.5	21	31.5	39	52	78		7	14	21			52			
RESISTENZA ARMATURA	Rarm																	
Armature resistance	[Ohm]		5.3	1.41	0.67	0.4	0.29	0.16		12.5	2.5	1.41			0.29			
INDUTTANZA ARMATURA	La																	
Armature inductance	[mH]		18.5	4.1	2	1.2	0.7	0.32		42	9.46	4.1	2.74	1.45	0.7			
COST. TENSIONE	Ke																	
Voltage constant	[V/Krpm]		55.5	27	19	15	11.4	7.5		84.5	40	27	21		11.4			
COST. TEMPO ELET.	Te																	
Elect.time constant	[ms]		3.5	3.13	3	3	2.4	2		3.4	3.8	3.13			2.4			
COST. TEMPO MECC.	Tm																	
Mech.time constant	[ms]		13	19	14	14	17	22		13	12	19			17			

\* Solo per servizio intermittente - Only intermittent duty

**DATI MECCANICI - Mechanical data**

INERZIA ROTORE	Jm	
Rotor inertia	[Kgm <sup>2</sup> ]	0.0007
MAX ACC. TEORICA		
Max theor. Acc.	[Rad/sec <sup>2</sup> ]	6850
CARICO RADIALE MAX	RI	
Max radial load	[N]	343
CARICO ASSIALE MAX	AI	
Max axial load	[N]	103
PESO MOTORE	G	
Motor weight	[Kg]	5.3
VENTILAZIONE		NATURALE
Ventilation		T.E.N.V.
GRADO DI PROTEZIONE		
Class protection	IP	54

**DATI ELETTRICI - Winding data**

COST. DI TEMPO TERMICO	Tt	
Thermal time constant	[min]	35
MAX VEL. SENZA CARICO	No max	
Max no load speed	[rpm]	4000
MAX VEL. CON CARICO	N max	
Max load speed	[rpm]	3000
CLASSE D'ISOLAMENTO		
Insulation class		F
FATTORE DI SERVIZIO		
Duty cycle		S1
FATTORE DI FORMA		
Form factor	FF	1
TEMP. AMBIENTE RIF. DATI	T rif	
Room temp. data refer.	[°C]	40°

SERIE  
Series

**PENTA 5M**

W	RPM
<b>360</b>	<b>3000</b>
<b>240</b>	<b>2000</b>

**CARATTERISTICHE GENERALI - Performance characteristics**

TIPO MOTORE	5M 30								5M 20								
Motor type																	
POTENZA RESA	P <sub>nom</sub>																
Rated power	[W]	360								240							
VELOCITA' NOMINALE	N <sub>nom</sub>																
Rated speed	[rpm]	3000								2000							
COPPIA NOMINALE	C <sub>nom</sub>																
Rated torque	[Nm]	1.15								1.15							
TENSIONE NOMINALE	V <sub>nom</sub>																
Rated voltage	[V]	180	90	60	48	36	24*	12*	180	90	60	48	36	24	12*		
CORRENTE NOMINALE	I <sub>nom</sub>																
Rated current	[A]	2.6	5	7.5	9.4	12.5			1.7	3.4	5	6.25	8.3	12.5			
COPPIA MASSIMA	C <sub>max</sub>																
Peak torque	[Nm]	5.75	5.75	5.75	5.75	5.75			5.75	5.75	5.75	5.75	5.75	5.75			
CORRENTE MASSIMA	I <sub>max</sub>																
Peak current	[A]	12.6	25	37.5	47	62.5			8.5	17	25			62.5			
RESISTENZA ARMATURA	R <sub>arm</sub>																
Armature resistance	[Ohm]	4.05	0.9	0.52	0.35	0.25			7.2	1.84	0.9			0.25			
INDUTTANZA ARMATURA	L <sub>a</sub>																
Armature inductance	[mH]	14.3	3	1.43	1	0.56			27	6.8	3	2	1.2	0.56			
COST. TENSIONE	K <sub>e</sub>																
Voltage constant	[V/Krpm]		27	19.5	15.5	11.5			87	40	27			11.5			
COST. TEMPO ELET.	T <sub>e</sub>																
Elect.time constant	[ms]		3.4	2.75	2.9	2.5			3.75	3.7	3.4			2.5			
COST. TEMPO MECC.	T <sub>m</sub>																
Mech.time constant	[ms]		10	12	13	14			8	10	10			14			

\* Solo per servizio intermittente - Only intermittent duty

**DATI MECCANICI - Mechanical data**

INERZIA ROTORE	J <sub>m</sub>	
Rotor inertia	[Kgm <sup>2</sup> ]	0.0008
MAX ACC. TEORICA		
Max theor. Acc.	[Rad/sec <sup>2</sup> ]	7187
CARICO RADIALE MAX	R <sub>I</sub>	
Max radial load	[N]	343
CARICO ASSIALE MAX	A <sub>I</sub>	
Max axial load	[N]	103
PESO MOTORE	G	
Motor weight	[Kg]	6.4
VENTILAZIONE		NATURALE
Ventilation		T.E.N.V.
GRADO DI PROTEZIONE		
Class protection	IP	54

**DATI ELETTRICI - Winding data**

COST. DI TEMPO TERMICO	T <sub>t</sub>	
Thermal time constant	[min]	45
MAX VEL. SENZA CARICO	No max	
Max no load speed	[rpm]	4000
MAX VEL. CON CARICO	N max	
Max load speed	[rpm]	3000
CLASSE D'ISOLAMENTO		
Insulation class		F
FATTORE DI SERVIZIO		
Duty cycle		S1
FATTORE DI FORMA		
Form factor	FF	1
TEMP. AMBIENTE RIF. DATI	T <sub>rif</sub>	
Room temp. data refer.	[°C]	40°

SERIE  
Series

**PENTA 5L**

<b>W</b>	<b>RPM</b>
<b>500</b>	<b>3000</b>
<b>335</b>	<b>2000</b>

**CARATTERISTICHE GENERALI - Performance characteristics**

TIPO MOTORE	5L 30						5L 20									
Motor type	5L 30						5L 20									
POTENZA RESA	Pnom															
Rated power	[W]		500						335							
VELOCITA' NOMINALE	Nnom															
Rated speed	[rpm]		3000						2000							
COPPIA NOMINALE	Cnom															
Rated torque	[Nm]		1.6						1.6							
TENSIONE NOMINALE	Vnom															
Rated voltage	[V]		180	90	60	48	36*	24*	12*	180	90	60	48	36	24*	12*
CORRENTE NOMINALE	Inom															
Rated current	[A]		3.3	6.6	10.5	13				2.2	4.4	6.6	10			
COPPIA MASSIMA	Cmax															
Peak torque	[Nm]		8	8	8	8				8	8	8	8			
CORRENTE MASSIMA	Imax															
Peak current	[A]		16.5	33	51.5	65				11	22	33				
RESISTENZA ARMATURA	Rarm															
Armature resistance	[Ohm]		2.62	0.86	1.42	0.16				5.4	1.1	0.86				
INDUTTANZA ARMATURA	La															
Armature inductance	[mH]		8.8	2.2	0.95	0.35				18.5	4.3	2.2	1.39			
COST. TENSIONE	Ke															
Voltage constant	[V/Krpm]		57	27.7	17.8	11.5				84	40	27.7	21.5			
COST. TEMPO ELET.	Te															
Elect.time constant	[ms]		3.4	2.6		2.2				3.43	3.9	2.6				
COST. TEMPO MECC.	Tm															
Mech.time constant	[ms]		9	12		14				8	7	12				

\* Solo per servizio intermittente - Only intermittent duty

**DATI MECCANICI - Mechanical data**

INERZIA ROTORE	Jm	
Rotor inertia	[Kgm <sup>2</sup> ]	0.001
MAX ACC. TEORICA		
Max theor. Acc.	[Rad/sec <sup>2</sup> ]	8000
CARICO RADIALE MAX	RI	
Max radial load	[N]	343
CARICO ASSIALE MAX	AI	
Max axial load	[N]	103
PESO MOTORE	G	
Motor weight	[Kg]	8
VENTILAZIONE		NATURALE
Ventilation		T.E.N.V.
GRADO DI PROTEZIONE		
Class protection	IP	54

**DATI ELETTRICI - Winding data**

COST. DI TEMPO TERMICO	Tt	
Thermal time constant	[min]	55
MAX VEL. SENZA CARICO	No max	
Max no load speed	[rpm]	4000
MAX VEL. CON CARICO	N max	
Max load speed	[rpm]	3000
CLASSE D'ISOLAMENTO		
Insulation class		F
FATTORE DI SERVIZIO		
Duty cycle		S1
FATTORE DI FORMA		
Form factor	FF	1
TEMP. AMBIENTE RIF. DATI	T rif	
Room temp. data refer.	[°C]	40°

# PENTA 5

MOTORI C.C.

D.C. MOTORS



DIMENSIONI (mm) DIMENSIONS (mm)

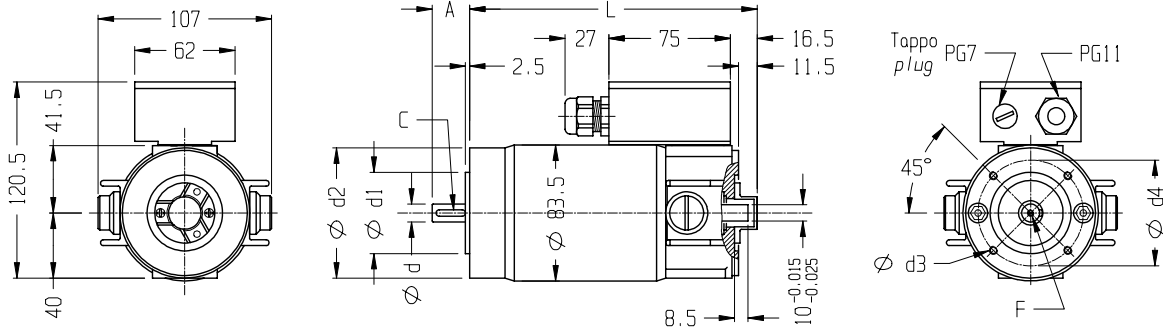

Type	X	XS		S		SL		M		L	
Size	B14/56	B14/56	B14/63	B14/56	B14/63	B14/63	B14/71	B14/63	B14/71	B14/63	B14/71
A	20	20	23	20	23	23	30	23	30	23	30
L	144.5	177.5		212.5		229		267.5		322.5	
d(h7)	9	9	11	9	11	11	14	11	14	11	14
F	-	-	M4	-	M4	M4	M5	M4	M5	M4	M5
C	3x3x15	3x3x15	4x4x18	3x3x15	4x4x18	4x4x18	5x5x25	4x4x18	5x5x25	4x4x18	5x5x25
d1(h7)	50	50	60	50	60	60	70	60	70	60	70
d2	80	80	90	80	90	90	105	90	105	90	105
d3	M5	M5	M5	M5	M5	M5	M6	M5	M6	M5	M6
d4	65	65	75	65	75	75	85	75	85	75	85

## FLANGIA B5

## B5 FLANGE

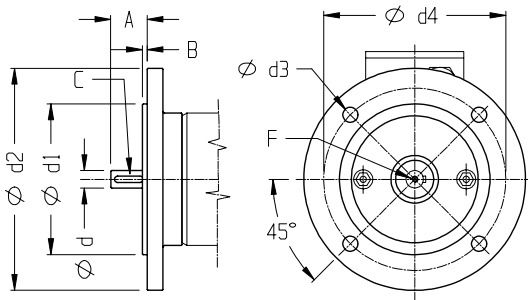

Size	A	B	C	d(h7)	d1(h7)	d2	d3	d4	F
56	20	3	3x3x15	9	80	120	8.5	100	-
63	23	3	4x4x18	11	95	140	9.5	115	M4
71	30	3.5	5x5x25	14	110	160	9.5	130	M5

## FLANGIA B14

## B14 FLANGE

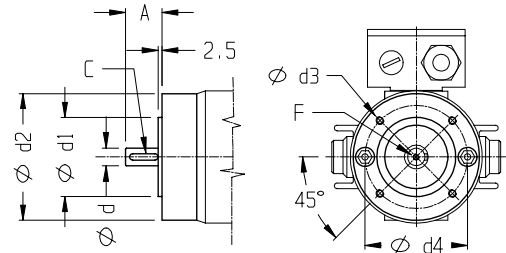

Size	A	C	d(h7)	d1(h7)	d2	d3	d4	F
56	20	3x3x15	9	50	80	M5	65	-
63	23	4x4x18	11	60	90	M5	75	M4
71	30	5x5x25	14	70	105	M6	85	M5

## CONNETTORE

## CONNECTOR

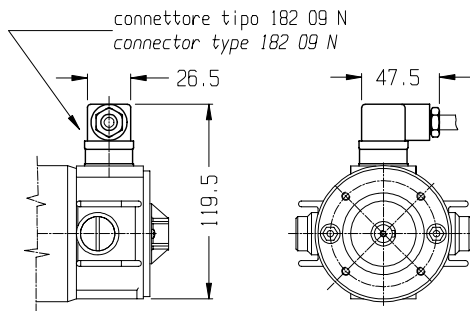

## CAVO

## FLYING LEADS

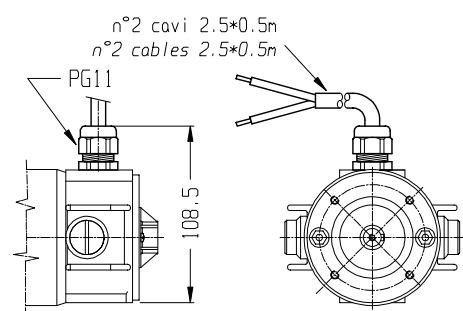

## OPTIONALS

**FLANGIA B3-B14/56**

*B3-B14/56 FLANGE*

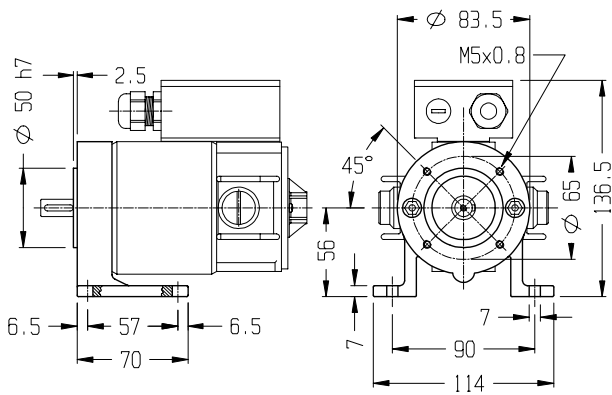

**PIEDE A FASCIA**

*FOOT BAND TYPE*

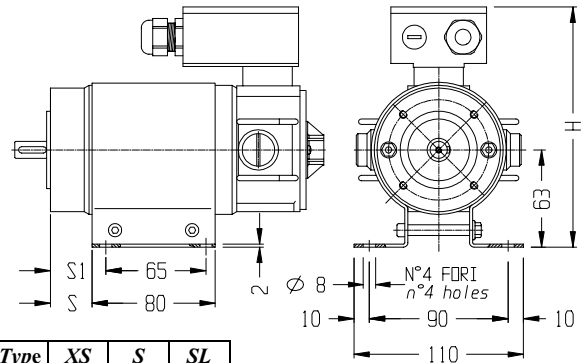

**PASSACAVO**

*CABLE GLAND*

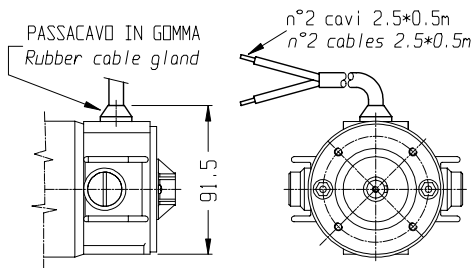

**PRED. ENCODER**

*ENC. PREARRANGEMENT*

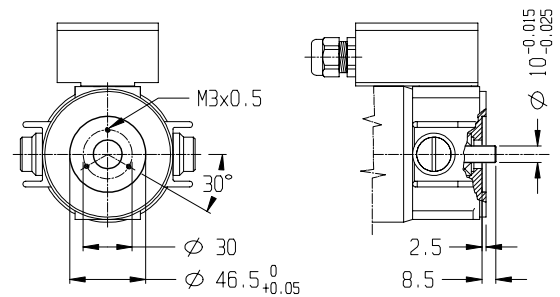

**ENCODER EH53**

*ENCODER EH53*

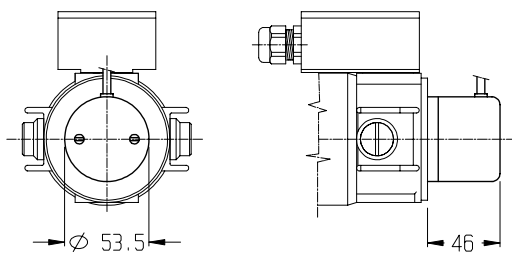

**ENCODER EH38**

*ENCODER EH38*

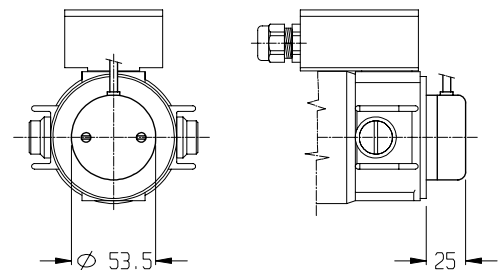

# PENTA 5

MOTORI C.C.

D.C. MOTORS



## OPTIONALS

**DISTANZ. ENC. N°1**      *ENCODER SPACER N°1*

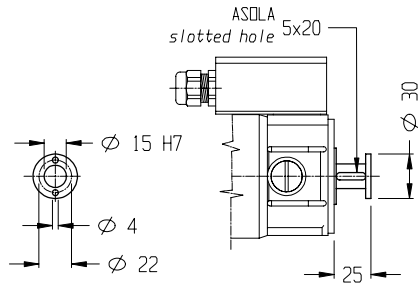

**DISTANZ. ENC. N°2**      *ENCODER SPACER N°2*

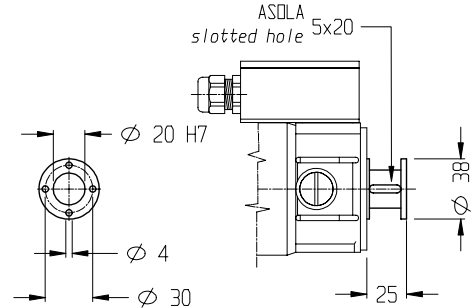

**DISTANZ. ENC. N°3**      *ENCODER SPACER N°3*

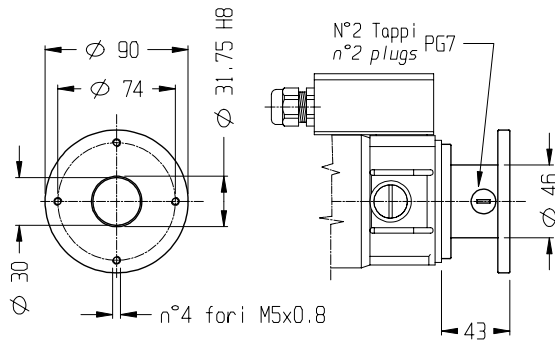

**DIN. TACHIMETRICA**      *TACHO GENERATOR*

**PREDISPOSTO ENCODER**      *ENCODER PREARRANGEMENT*

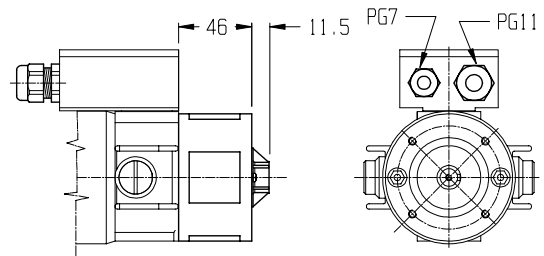

<b>COSTANTE DI TENSIONE</b> <i>VOLTAGE CONSTANT</i>	10±5% V/KRPM	<b>CORRENTE NOMINALE</b> <i>RATED CURRENT</i>	2 mA
<b>VELOCITA' MASSIMA</b> <i>MAX SPEED</i>	9000 RPM	<b>CORRENTE MASSIMA</b> <i>MAX CURRENT</i>	8 mA

**FRENO 1,7 Nm**

*BRAKE 1,7 Nm*

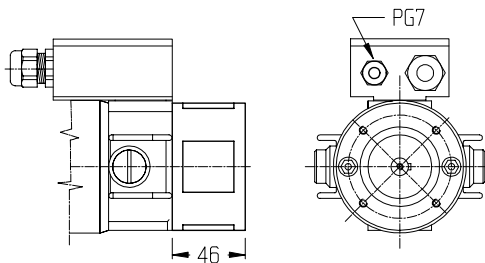

<b>COPPIA STATICA</b> <i>STATIC TORQUE</i>	1,7 Nm	<b>CORRENTE</b> <i>CURRENT</i>	0.46-0.058 A
<b>TENSIONE DI ALIMEN.</b> <i>POWER SUPPLY VOLTAGE</i>	24-190 V.c.c.	<b>POTENZA ASSORBITA</b> <i>INPUT POWER</i>	11 W

**FRENO 1,7 Nm + DIN. TACHO GENERATOR + TACHIMETRICA**      *TACHO GENERATOR + BRAKE 1,7 Nm*

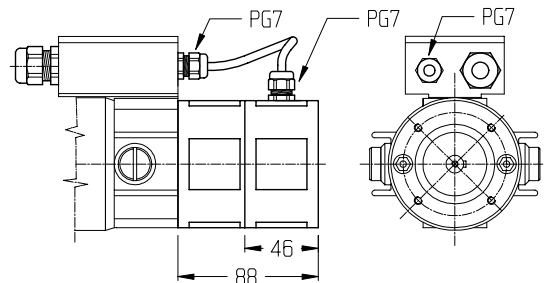

	<b>FRENO</b> <i>BRAKE</i>	<b>DINAMO T.</b> <i>TACHO G.</i>
<b>COPPIA STATICA</b> <i>STATIC TORQUE</i>	1,7 Nm	<b>COSTANTE DI TENSIONE</b> <i>VOLTAGE CONSTANT</i>
<b>TENSIONE DI ALIMEN.</b> <i>POWER SUPPLY VOLTAGE</i>	24-190 V.c.c.	<b>VELOCITA' MASSIMA</b> <i>MAX SPEED</i>
<b>CORRENTE</b> <i>CURRENT</i>	0.46-0.058 A	<b>CORRENTE NOMINALE</b> <i>RATED CURRENT</i>
<b>POTENZA ASSORBITA</b> <i>INPUT POWER</i>	11 W	<b>CORRENTE MASSIMA</b> <i>MAX CURRENT</i>

# PENTA 5

MOTORI C.C.

D.C. MOTORS



## OPTIONALS

**FRENO 4 Nm**

*BRAKE 4 Nm*

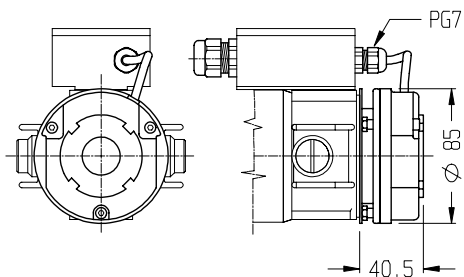

<b>COPPIA STATICA</b> <i>STATIC TORQUE</i>	4 Nm	<b>CORRENTE</b> <i>CURRENT</i>	0.83-0.109 A
<b>TENSIONE DI ALIMEN.</b> <i>POWER SUPPLY VOLTAGE</i>	24-190 V.c.c.	<b>POTENZA ASSORBITA</b> <i>INPUT POWER</i>	20 W

**FRENO 4 Nm + DIN.**  
**TACHIMETRICA**

*TACHO GENERATOR +*  
*BRAKE 4 Nm*

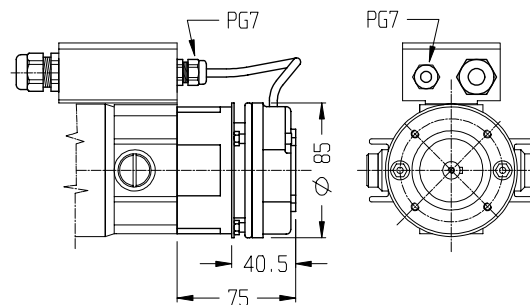

FRENO	BRAKE	DINAMO T.	TACHO G.
<b>COPPIA STATICA</b> <i>STATIC TORQUE</i>	4 Nm	<b>COSTANTE DI TENSIONE</b> <i>VOLTAGE CONSTANT</i>	10±5% V/KRPM
<b>TENSIONE DI ALIMEN.</b> <i>POWER SUPPLY VOLTAGE</i>	24-190 V.c.c.	<b>VELOCITA' MASSIMA</b> <i>MAX SPEED</i>	9000 RPM
<b>CORRENTE</b> <i>CURRENT</i>	0.83-0.109 A	<b>CORRENTE NOMINALE</b> <i>RATED CURRENT</i>	2 mA
<b>POTENZA ASSORBITA</b> <i>INPUT POWER</i>	20 W	<b>CORRENTE MASSIMA</b> <i>MAX CURRENT</i>	8 mA

# MOTORI IN CORRENTE CONTINUA

## D.C. MOTORS



SERIE  
Series

# PENTA

# 5XA

W	RPM
150	3000
100	2000

### CARATTERISTICHE GENERALI - Performance characteristics

TIPO MOTORE		5XA 30								5XA 20							
Motor type																	
POTENZA RESA	P <sub>nom</sub>																
Rated power	[W]	150								100							
VELOCITA' NOMINALE	N <sub>nom</sub>																
Rated speed	[rpm]	3000								2000							
COPPIA NOMINALE	C <sub>nom</sub>																
Rated torque	[Nm]	0.48								0.48							
TENSIONE NOMINALE	V <sub>nom</sub>																
Rated voltage	[V]	180	90	60	48	36	24	12	180	90	60	48	36	24	12		
CORRENTE NOMINALE	I <sub>nom</sub>																
Rated current	[A]	1.1		3.3	4	5.54	8.33	16	0.74	1.54	2.2	2.8		5.5	11		
COPPIA MASSIMA	C <sub>max</sub>																
Peak torque	[Nm]	2.4		2.4	2.4	2.4	2.4	2.4	2.4	2.4	2.4	2.4		2.4	2.4		
CORRENTE MASSIMA	I <sub>max</sub>																
Peak current	[A]	5.5		16.7	20	27.7	41.7	80	3.7	7.7	11	14		27.5	55		
RESISTENZA ARMATURA	R <sub>arm</sub>																
Armature resistance	[Ohm]	16.1		1.8	1.1	0.74	0.45	0.1	44.1	10.9	4	2.7		0.53	0.17		
INDUTTANZA ARMATURA	L <sub>a</sub>																
Armature inductance	[mH]	51.5		5.4	3	1.8	0.9	0.18	145.5	35.4	12.6	8		1.32	0.34		
COST. TENSIONE	K <sub>e</sub>																
Voltage constant	[V/Krpm]	50		16.5	13.5	10	6.5	3.5	70	35.5	24	19		8	4.8		
COST. TEMPO ELET.	T <sub>e</sub>																
Elect.time constant	[ms]	3.2		3	2.7	2.4	2.2	1.8	3.3	3.25	3.15	3		2.5	2		
COST. TEMPO MECC.	T <sub>m</sub>																
Mech.time constant	[ms]	13		13	12	14	19	16	18	17	14	15		13	12		

\* Solo per servizio intermittente - Only intermittent duty

### DATI MECCANICI - Mechanical data

INERZIA ROTORE	J <sub>m</sub>	
Rotor inertia	[Kgm <sup>2</sup> ]	0.00018
MAX ACC. TEORICA		
Max theor. Acc.	[Rad/sec <sup>2</sup> ]	13300
CARICO RADIALE MAX	R <sub>I</sub>	
Max radial load	[N]	294
CARICO ASSIALE MAX	A <sub>I</sub>	
Max axial load	[N]	88
PESO MOTORE	G	
Motor weight	[Kg]	3.6
VENTILAZIONE	AUTOVENTILATO	
Ventilation	T.E.N.V.	
GRADO DI PROTEZIONE		
Class protection	IP	54

### DATI ELETTRICI - Winding data

COST. DI TEMPO TERMICO	T <sub>t</sub>	
Thermal time constant	[min]	30
MAX VEL. SENZA CARICO	No max	
Max no load speed	[rpm]	4000
MAX VEL. CON CARICO	N max	
Max load speed	[rpm]	3000
CLASSE D'ISOLAMENTO		
Insulation class		F
FATTORE DI SERVIZIO		
Duty cycle		S1
FATTORE DI FORMA		
Form factor	FF	1
TEMP. AMBIENTE RIF. DATI	T <sub>rif</sub>	
Room temp. data refer.	[°C]	40°

SERIE  
Series

**PENTA**

**5XSA**

<b>W</b>	<b>RPM</b>
<b>235</b>	<b>3000</b>
<b>155</b>	<b>2000</b>

**CARATTERISTICHE GENERALI - Performance characteristics**

TIPO MOTORE <i>Motor type</i>		5XSA 30							5XSA 20						
POTENZA RESA <i>Rated power</i>	P <sub>nom</sub> [W]	235							155						
VELOCITA' NOMINALE <i>Rated speed</i>	N <sub>nom</sub> [rpm]	3000							2000						
COPPIA NOMINALE <i>Rated torque</i>	C <sub>nom</sub> [Nm]	0.75							0.75						
TENSIONE NOMINALE <i>Rated voltage</i>	V <sub>nom</sub> [V]	180	90	60	48	36	24	12*	180	90	60	48	36	24	12*
CORRENTE NOMINALE <i>Rated current</i>	I <sub>nom</sub> [A]	1.7	3.4	5	6.25	8.3	12.5		1.14	2.28	3.4	4.3	5.7	8.54	
COPPIA MASSIMA <i>Peak torque</i>	C <sub>max</sub> [Nm]	3.75	3.75	3.75	3.75	3.75	3.75		3.75	3.75	3.75	3.75	3.75	3.75	
CORRENTE MASSIMA <i>Peak current</i>	I <sub>max</sub> [A]	8.5		25	31	41.5	62.5		5.7	11.4	17	21.5		42.7	
RESISTENZA ARMATURA <i>Armature resistance</i>	R <sub>arm</sub> [Ohm]	13.65		1.5	0.9	0.58	0.38		30.6	7.6	3.3	2.25		0.41	
INDUTTANZA ARMATURA <i>Armature inductance</i>	L <sub>a</sub> [mH]	47	11.5	4.5	2.5	1.6	0.825		107	26	10.4	6.45	4	1.45	
COST. TENSIONE <i>Voltage constant</i>	K <sub>e</sub> [V/Krpm]	50		16.5	13.5	10	6.5		70	35.5	24	19		8	
COST. TEMPO ELET. <i>Elect. time constant</i>	T <sub>e</sub> [ms]	3.45		3	2.8	2.75	2.17		3.5	3.4	3.12	2.9		2.3	
COST. TEMPO MECC. <i>Mech. time constant</i>	T <sub>m</sub> [ms]	18		18	16	21	28		20	20	19	20		21	

\* Solo per servizio intermittente - *Only intermittent duty*

**DATI MECCANICI - Mechanical data**

INERZIA ROTORE <i>Rotor inertia</i>	J <sub>m</sub> [Kg <sup>m</sup> ²]	0.0003
MAX ACC. TEORICA <i>Max theor. Acc.</i>	[Rad/sec <sup>2</sup> ]	12500
CARICO RADIALE MAX <i>Max radial load</i>	R <sub>I</sub> [N]	294
CARICO ASSIALE MAX <i>Max axial load</i>	A <sub>I</sub> [N]	88
PESO MOTORE <i>Motor weight</i>	G [Kg]	4.2
VENTILAZIONE <i>Ventilation</i>	AUTOVENTILATO T.E.N.V.	
GRADO DI PROTEZIONE <i>Class protection</i>	IP	54

**DATI ELETTRICI - Winding data**

COST. DI TEMPO TERMICO <i>Thermal time constant</i>	T <sub>t</sub> [min]	35
MAX VEL. SENZA CARICO <i>Max no load speed</i>	No max [rpm]	4000
MAX VEL. CON CARICO <i>Max load speed</i>	N max [rpm]	3000
CLASSE D'ISOLAMENTO <i>Insulation class</i>		F
FATTORE DI SERVIZIO <i>Duty cycle</i>		S1
FATTORE DI FORMA <i>Form factor</i>	FF	1
TEMP. AMBIENTE RIF. DATI <i>Room temp. data refer.</i>	T rif [°C]	40°

SERIE  
Series

**PENTA**

**5SA**

<b>W</b>	<b>RPM</b>
<b>300</b>	<b>3000</b>
<b>200</b>	<b>2000</b>

**CARATTERISTICHE GENERALI - Performance characteristics**

TIPO MOTORE	5SA 30								5SA 20								
Motor type																	
POTENZA RESA Rated power	Pnom [W]	300								200							
VELOCITA' NOMINALE Rated speed	Nnom [rpm]	3000								2000							
COPPIA NOMINALE Rated torque	Cnom [Nm]	0.96								0.96							
TENSIONE NOMINALE Rated voltage	Vnom [V]	180	90	60	48	36	24	12*	180	90	60	48	36	24	12*		
CORRENTE NOMINALE Rated current	Inom [A]	2.1	4.2	6.3	7.8	10.4	15.6		1.4	2.8	4.2	5.2	7	10.4			
COPPIA MASSIMA Peak torque	Cmax [Nm]	4.8	4.8	4.8	4.8	4.8	4.8		4.8	4.8	4.8	4.8	4.8	4.8			
CORRENTE MASSIMA Peak current	Imax [A]	10.5		31.5	39	52	78		7	14	21	26		52			
RESISTENZA ARMATURA Armature resistance	Rarm [Ohm]	5.9		0.76	0.49	0.32	0.18		11.7	2.9	1.6	1.1		0.235			
INDUTTANZA ARMATURA Armature inductance	La [mH]	19		2.2	1.32	0.8	0.38		36	9	4.9	3		0.52			
COST. TENSIONE Voltage constant	Ke [V/Krpm]	50		16.5	13.5	10	7		74	37	24	19		8.5			
COST. TEMPO ELET. Elect.time constant	Te [ms]	3.3		2.9	2.7	2.5	2.1		3.1	3.1	3.1	2.7		2.2			
COST. TEMPO MECC. Mech.time constant	Tm [ms]	15		18	17	21	24		14	14	15	20		21			

\* Solo per servizio intermittente - Only intermittent duty

**DATI MECCANICI - Mechanical data**

INERZIA ROTORE Rotor inertia	Jm [Kgm <sup>2</sup> ]	0.0006
MAX ACC. TEORICA Max theor. Acc.	[Rad/sec <sup>2</sup> ]	8000
CARICO RADIALE MAX Max radial load	RI [N]	294
CARICO ASSIALE MAX Max axial load	AI [N]	88
PESO MOTORE Motor weight	G [Kg]	5.5
VENTILAZIONE Ventilation	AUTOVENTILATO T.E.N.V.	
GRADO DI PROTEZIONE Class protection	IP	54

**DATI ELETTRICI - Winding data**

COST. DI TEMPO TERMICO Thermal time constant	Tt [min]	40
MAX VEL. SENZA CARICO Max no load speed	No max [rpm]	4000
MAX VEL. CON CARICO Max load speed	N max [rpm]	3000
CLASSE D'ISOLAMENTO Insulation class		F
FATTORE DI SERVIZIO Duty cycle		S1
FATTORE DI FORMA Form factor	FF	1
TEMP. AMBIENTE RIF. DATI Room temp. data refer.	T rif [°C]	40°

SERIE  
Series

**PENTA**

**5SLA**

W	RPM
<b>440</b>	<b>3000</b>
<b>290</b>	<b>2000</b>

**CARATTERISTICHE GENERALI - Performance characteristics**

TIPO MOTORE	5SLA 30								5SLA 20								
Motor type																	
POTENZA RESA Rated power	Pnom [W]	440								290							
VELOCITA' NOMINALE Rated speed	Nnom [rpm]	3000								2000							
COPPIA NOMINALE Rated torque	Cnom [Nm]	1.4								1.4							
TENSIONE NOMINALE Rated voltage	Vnom [V]	180	90	60	48	36	24*	12*	180	90	60	48	36	24	12*		
CORRENTE NOMINALE Rated current	Inom [A]	3	6	9	11.3	15			2	4	6	7.5	10	15			
COPPIA MASSIMA Peak torque	Cmax [Nm]	7	7	7	7	7			7	7	7	7	7	7			
CORRENTE MASSIMA Peak current	Imax [A]	15	30	45	56.5	75			10	20	30	37.5	50	75			
RESISTENZA ARMATURA Armature resistance	Rarm [Ohm]	4.86	1.37	0.54	0.45	0.27			11	3.05	1.37	0.88	0.45	0.25			
INDUTTANZA ARMATURA Armature inductance	La [mH]	17	4.45	1.84	1.4	0.62			37.8	10.3	4.45	2.5	1.4	0.57			
COST. TENSIONE Voltage constant	Ke [V/Krpm]	53	26	17	14.5	10.5			78	39	26	20.5	14.5	9			
COST. TEMPO ELET. Elect.time constant	Te [ms]	3.5	3.3	3.4	3.1	2.3			3.45	3.4	3.3	2.84	3.1	2.3			
COST. TEMPO MECC. Mech.time constant	Tm [ms]	13	14	14	16	18			14	15	14	15	16	25			

\* Solo per servizio intermittente - Only intermittent duty

**DATI MECCANICI - Mechanical data**

INERZIA ROTORE Rotor inertia	Jm [Kgm <sup>2</sup> ]	0.0007
MAX ACC. TEORICA Max theor. Acc.	[Rad/sec <sup>2</sup> ]	10000
CARICO RADIALE MAX Max radial load	RI [N]	343
CARICO ASSIALE MAX Max axial load	AI [N]	103
PESO MOTORE Motor weight	G [Kg]	6.25
VENTILAZIONE Ventilation	AUTOVENTILATO T.E.N.V.	
GRADO DI PROTEZIONE Class protection	IP	54

**DATI ELETTRICI - Winding data**

COST. DI TEMPO TERMICO Thermal time constant	Tt [min]	40
MAX VEL. SENZA CARICO Max no load speed	No max [rpm]	4000
MAX VEL. CON CARICO Max load speed	N max [rpm]	3000
CLASSE D'ISOLAMENTO Insulation class		F
FATTORE DI SERVIZIO Duty cycle		S1
FATTORE DI FORMA Form factor	FF	1
TEMP. AMBIENTE RIF. DATI Room temp. data refer.	T rif [°C]	40°

SERIE  
Series

**PENTA**

**5MA**

<b>W</b>	<b>RPM</b>
<b>565</b>	<b>3000</b>
<b>375</b>	<b>2000</b>

**CARATTERISTICHE GENERALI - Performance characteristics**

TIPO MOTORE Motor type		5MA 30						5MA 20							
POTENZA RESA Rated power	Pnom [W]	565						375							
VELOCITA' NOMINALE Rated speed	Nnom [rpm]	3000						2000							
COPPIA NOMINALE Rated torque	Cnom [Nm]	1.8						1.8							
TENSIONE NOMINALE Rated voltage	Vnom [V]	180	90	60	48	36*	24*	12*	180	90	60	48	36	24*	12*
CORRENTE NOMINALE Rated current	Inom [A]	3.7	7.4	11	13.8				2.5	5	7.4	9.3	13.8		
COPPIA MASSIMA Peak torque	Cmax [Nm]	9	9	9	9				9	9	9	9	9		
CORRENTE MASSIMA Peak current	Imax [A]	18.5	37	55	69				12.5	25	37	46.5			
RESISTENZA ARMATURA Armature resistance	Rarm [Ohm]	3.65	0.93	0.49	0.33				6.8	2.2	0.93	0.55			
INDUTTANZA ARMATURA Armature inductance	La [mH]	12	2.8	1.6	0.85				23	7	2.8	1.5	1.08		
COST. TENSIONE Voltage constant	Ke [V/Krpm]	54.5	26	18	14.5				82	41.5	26	22	16		
COST. TEMPO ELET. Elect.time constant	Te [ms]	3.3	3	3.2	2.6				3.4	3.2	3	2.7			
COST. TEMPO MECC. Mech.time constant	Tm [ms]	11	12	13	13				9	11	12	10			

\* Solo per servizio intermittente - Only intermittent duty

**DATI MECCANICI - Mechanical data**

INERZIA ROTORE Rotor inertia	Jm [Kgm <sup>2</sup> ]	0.0008
MAX ACC. TEORICA Max theor. Acc.	[Rad/sec <sup>2</sup> ]	11250
CARICO RADIALE MAX Max radial load	RI [N]	343
CARICO ASSIALE MAX Max axial load	AI [N]	103
PESO MOTORE Motor weight	G [Kg]	7.5
VENTILAZIONE Ventilation	AUTOVENTILATO T.E.N.V.	
GRADO DI PROTEZIONE Class protection	IP	54

**DATI ELETTRICI - Winding data**

COST. DI TEMPO TERMICO Thermal time constant	Tt [min]	40
MAX VEL. SENZA CARICO Max no load speed	No max [rpm]	4000
MAX VEL. CON CARICO Max load speed	N max [rpm]	3000
CLASSE D'ISOLAMENTO Insulation class		F
FATTORE DI SERVIZIO Duty cycle		S1
FATTORE DI FORMA Form factor	FF	1
TEMP. AMBIENTE RIF. DATI Room temp. data refer.	T rif [°C]	40°

# PENTA5A

MOTORI C.C.

D.C. MOTORS



**DIMENSIONI (mm) DIMENSIONS (mm)**

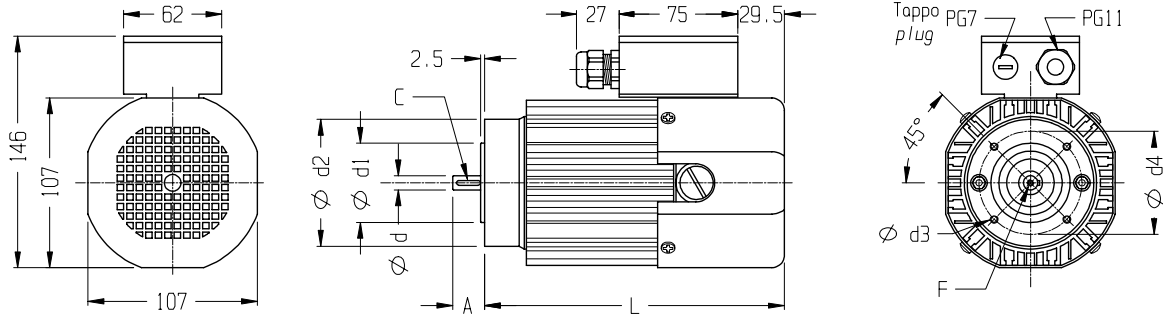

Type	X	XS		S		SL		M	
Size	B14/56	B14/56	B14/63	B14/56	B14/63	B14/63	B14/71	B14/63	B14/71
A	20	20	23	20	23	23	30	23	30
L	156.5	189.5		224.5		241		279.5	
d(h7)	9	9	11	9	11	11	14	11	14
F	-	-	M4	-	M4	M4	M5	M4	M5
C	3x3x15	3x3x15	4x4x18	3x3x15	4x4x18	4x4x18	5x5x25	4x4x18	5x5x25
d1(h7)	50	50	60	50	60	60	70	60	70
d2	80	80	90	80	90	90	105	90	105
d3	M5	M5	M5	M5	M5	M5	M6	M5	M6
d4	65	65	75	65	75	75	85	75	85

## FLANGIA B5

## B5 FLANGE

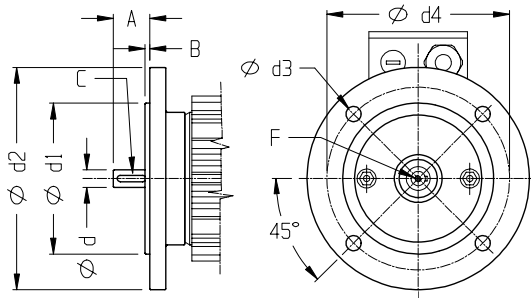

Size	A	B	C	d(h7)	d1(h7)	d2	d3	d4	F
56	20	3	3x3x15	9	80	120	8.5	100	-
63	23	3	4x4x18	11	95	140	9.5	115	M4
71	30	3.5	5x5x25	14	110	160	9.5	130	M5

## FLANGIA B14

## B14 FLANGE

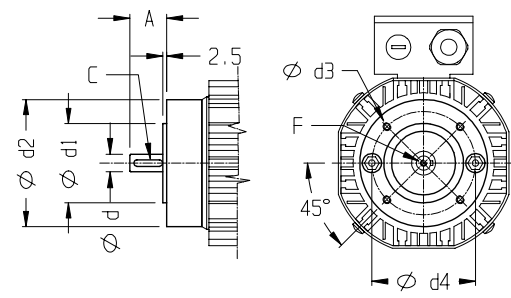

Size	A	C	d(h7)	d1(h7)	d2	d3	d4	F
56	20	3x3x15	9	50	80	M5	65	-
63	23	4x4x18	11	60	90	M5	75	M4
71	30	5x5x25	14	70	105	M6	85	M5

## CAVO

## FLYING LEADS

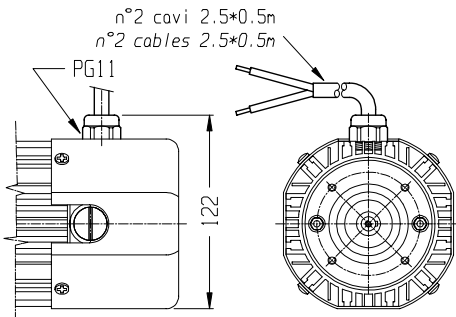

## CONNETTORE

## CONNECTOR

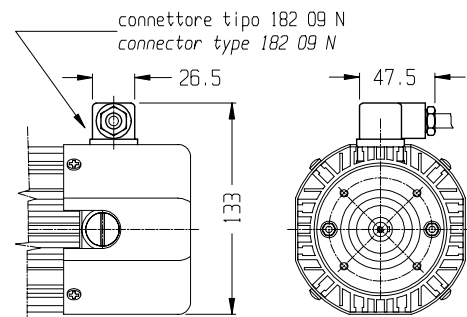

# PENTA 5A

MOTORI C.C.

D.C. MOTORS



## OPTIONALS

### PIEDE B3

### B3 FOOT

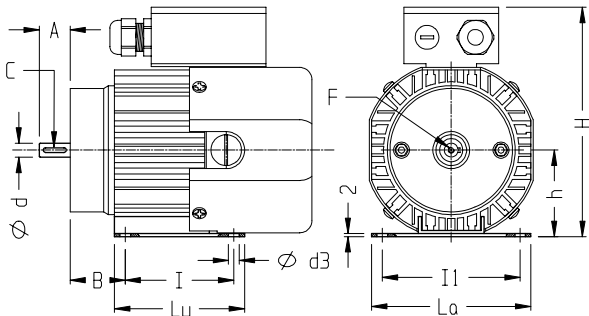

Type	XS			S		SL			M	
Size	B3/56	B3/56	B3/63	B3/56	B3/63	B3/63	B3/71	B3/63	B3/71	
A	20	20	23	20	23	23	30	23	30	
d(h7)	9	9	11	9	11	11	14	11	14	
Lu	85	85	95	85	95	95	104	95	104	
La	104	104	114	104	114	114	126	114	126	
F	-	-	M4	-	M4	M4	M5	M4	M5	
C	3x3x1	3x3x1	4x4x1	3x3x1	4x4x1	4x4x1	5x5x2	4x4x1	5x5x2	
B	36	36	40	36	40	40	45	40	45	
I	71	71	80	71	80	80	90	80	90	
I1	90	90	100	90	100	100	112	100	112	
H	148.5	148.5	155.5	148.5	155.5	155.5	163.5	155.5	163.5	
h	56	56	63	56	63	63	71	63	71	
d3	7	7	9	7	9	9	9	9	9	

### FLANGIA B3

### B3 FLANGE

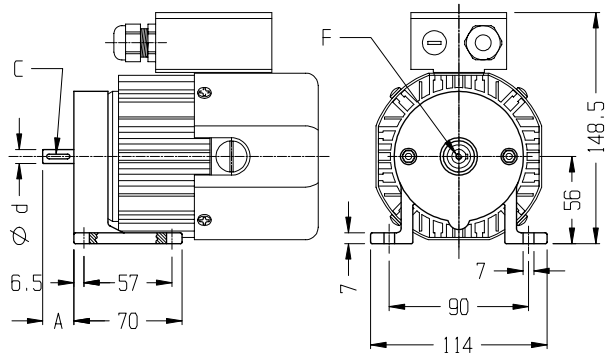

Type	X	XS		S		SL		M	
A	20	20	23	20	23	23	30	23	30
d(h7)	9	9	11	9	11	11	14	11	14
F	-	-	M4	-	M4	M4	M5	M4	M5
C	3x3x1	3x3x1	4x4x1	3x3x1	4x4x1	4x4x1	5x5x2	4x4x1	5x5x2

### DIN. TACHIMETRICA

### TACHO GENERATOR

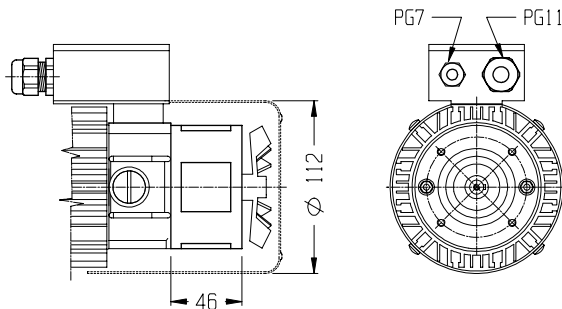

LA LUNGHEZZA TOTALE DEL MOTORE AUMENTA DI 42 mm  
THE TOTAL LENGTH OF THE MOTOR INCREASES OF 42 mm

COSTANTE DI TENSIONE VOLTAGE CONSTANT	10±5% V/KRPM	CORRENTE NOMINALE RATED CURRENT	2 mA
VELOCITA' MASSIMA MAX SPEED	9000 RPM	CORRENTE MASSIMA MAX CURRENT	8 mA

### FRENO 1,7 Nm

### BRAKE 1,7 Nm

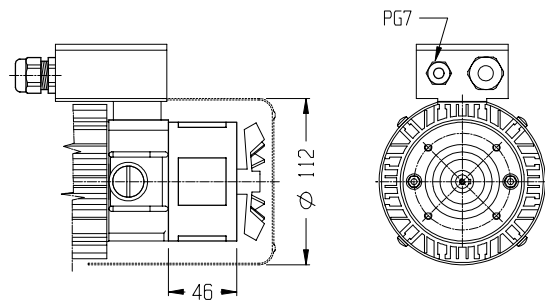

LA LUNGHEZZA TOTALE DEL MOTORE AUMENTA DI 42 mm  
THE TOTAL LENGTH OF THE MOTOR INCREASES OF 42 mm

COPPIA STATICA STATIC TORQUE	1,7 Nm	CORRENTE CURRENT	0.46-0.058 A
TENSIONE DI ALIMEN. POWER SUPPLY VOLTAGE	24-190 V.c.c.	POTENZA ASSORBITA INPUT POWER	11 W

### FRENO 4 Nm

### BRAKE 4 Nm

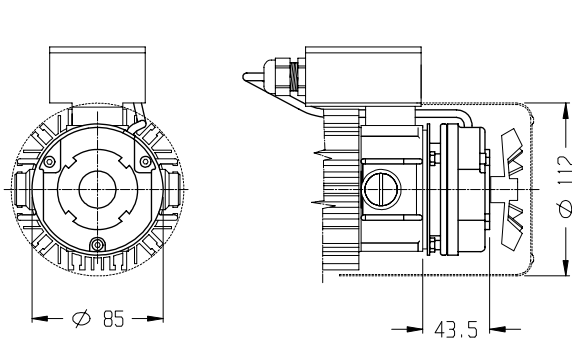

LA LUNGHEZZA TOTALE DEL MOTORE AUMENTA DI 42 mm  
THE TOTAL LENGTH OF THE MOTOR INCREASES OF 42 mm

COPPIA STATICA STATIC TORQUE	4 Nm
TENSIONE DI ALIMEN. POWER SUPPLY VOLTAGE	24-190 V.c.c.
CORRENTE CURRENT	0.83-0.109 A
POTENZA ASSORBITA INPUT POWER	20 W

SERIE  
Series

**PENTA**

**7SA**

<b>W</b>	<b>RPM</b>
<b>750</b>	<b>3000</b>
<b>500</b>	<b>2000</b>

**CARATTERISTICHE GENERALI - Performance characteristics**

TIPO MOTORE Motor type	7SA 30							7SA 20							
POTENZA RESA Rated power	Pnom [W]	750							500						
VELOCITA' NOMINALE Rated speed	Nnom [rpm]	3000							2000						
COPPIA NOMINALE Rated torque	Cnom [Nm]	2.4							2.4						
TENSIONE NOMINALE Rated voltage	Vnom [V]	180	90	60*	48*	36*	24*	180	90	60	48	36*	24*	12*	
CORRENTE NOMINALE Rated current	Inom [A]	5.7	10.6					3.55	7	14	14				
COPPIA MASSIMA Peak torque	Cmax [Nm]	12	12					12	12	12	13.25				
CORRENTE MASSIMA Peak current	Imax [A]	28.5	53					17.75	35	10.7					
RESISTENZA ARMATURA Armature resistance	Rarm [Ohm]	2.35	0.71					5.55	1.44						
INDUTTANZA ARMATURA Armature inductance	La [mH]	13.9	4.6					35.4	9	2.77	1.61				
COST. TENSIONE Voltage constant	Ke [V/Krpm]	58	29.5					87	44	26.1	20.3				
COST. TEMPO ELET. Elect.time constant	Te [ms]	5.9	6.5					6.4	6.3						
COST. TEMPO MECC. Mech.time constant	Tm [ms]	14	16					14	14						

\* Solo per servizio intermittente - Only intermittent duty

**DATI MECCANICI - Mechanical data**

INERZIA ROTORE Rotor inertia	Jm [Kgm <sup>2</sup> ]	0.0018
MAX ACC. TEORICA Max theor. Acc.	[Rad/sec <sup>2</sup> ]	6600
CARICO RADIALE MAX Max radial load	RI [N]	588
CARICO ASSIALE MAX Max axial load	AI [N]	176
PESO MOTORE Motor weight	G [Kg]	9.4
VENTILAZIONE Ventilation	AUTOVENTILATO T.E.N.V.	
GRADO DI PROTEZIONE Class protection	IP	54

**DATI ELETTRICI - Winding data**

COST. DI TEMPO TERMICO Thermal time constant	Tt [min]	45
MAX VEL. SENZA CARICO Max no load speed	No max [rpm]	4000
MAX VEL. CON CARICO Max load speed	N max [rpm]	3000
CLASSE D'ISOLAMENTO Insulation class		F
FATTORE DI SERVIZIO Duty cycle		S1
FATTORE DI FORMA Form factor	FF	1
TEMP. AMBIENTE RIF. DATI Room temp. data refer.	T rif [°C]	40°

SERIE  
Series

**PENTA**

**7MA**

<b>W</b>	<b>RPM</b>
<b>1100</b>	<b>3000</b>
<b>750</b>	<b>2000</b>

**CARATTERISTICHE GENERALI - Performance characteristics**

TIPO MOTORE <i>Motor type</i>		7MA 30						7MA 20						
POTENZA RESA <i>Rated power</i>	P <sub>nom</sub> [W]	1100						750						
VELOCITA' NOMINALE <i>Rated speed</i>	N <sub>nom</sub> [rpm]	3000						2000						
COPPIA NOMINALE <i>Rated torque</i>	C <sub>nom</sub> [Nm]	3.5						3.5						
TENSIONE NOMINALE <i>Rated voltage</i>	V <sub>nom</sub> [V]	180	90	60	48*	36*		180	90	60	48	36*	24*	
CORRENTE NOMINALE <i>Rated current</i>	I <sub>nom</sub> [A]	7.3	14.6	22.9				5.5	11	16.5	23			
COPPIA MASSIMA <i>Peak torque</i>	C <sub>max</sub> [Nm]	17.5	17.5	17.5				17.5	17.5	17.5	17.5			
CORRENTE MASSIMA <i>Peak current</i>	I <sub>max</sub> [A]	36.5	73	114.5				27.5	55		114			
RESISTENZA ARMATURA <i>Armature resistance</i>	R <sub>arm</sub> [Ohm]	0.85	0.26	0.30				1.51	0.45	0.5	0.22			
INDUTTANZA ARMATURA <i>Armature inductance</i>	L <sub>a</sub> [mH]	3.15	0.95	0.28				6.8	1.65	1.6	0.22			
COST. TENSIONE <i>Voltage constant</i>	K <sub>e</sub> [V/Krpm]	57.7	30	19.2				84	40	44	19.5			
COST. TEMPO ELET. <i>Elect. time constant</i>	T <sub>e</sub> [ms]	3.7	4.3					4.6	3.7					
COST. TEMPO MECC. <i>Mech. time constant</i>	T <sub>m</sub> [ms]	8	7					6	9					

\* Solo per servizio intermittente - *Only intermittent duty*

**DATI MECCANICI - Mechanical data**

INERZIA ROTORE <i>Rotor inertia</i>	J <sub>m</sub> [Kgm <sup>2</sup> ]	0.0028
MAX ACC. TEORICA <i>Max theor. Acc.</i>	[Rad/sec <sup>2</sup> ]	6250
CARICO RADIALE MAX <i>Max radial load</i>	R <sub>I</sub> [N]	588
CARICO ASSIALE MAX <i>Max axial load</i>	A <sub>I</sub> [N]	176
PESO MOTORE <i>Motor weight</i>	G [Kg]	13.6
VENTILAZIONE <i>Ventilation</i>	AUTOVENTILATO T.E.N.V.	
GRADO DI PROTEZIONE <i>Class protection</i>	IP	54

**DATI ELETTRICI - Winding data**

COST. DI TEMPO TERMICO <i>Thermal time constant</i>	T <sub>t</sub> [min]	55
MAX VEL. SENZA CARICO <i>Max no load speed</i>	No max [rpm]	4000
MAX VEL. CON CARICO <i>Max load speed</i>	N max [rpm]	3000
CLASSE D'ISOLAMENTO <i>Insulation class</i>		F
FATTORE DI SERVIZIO <i>Duty cycle</i>		S1
FATTORE DI FORMA <i>Form factor</i>	FF	1
TEMP. AMBIENTE RIF. DATI <i>Room temp. data refer.</i>	T rif [°C]	40°

SERIE  
Series

**PENTA 7LA**

<b>W</b>	<b>RPM</b>
<b>1500</b>	<b>3000</b>
<b>1100</b>	<b>2000</b>

**CARATTERISTICHE GENERALI - Performance characteristics**

TIPO MOTORE Motor type		7LA 30						7LA 20						
POTENZA RESA Rated power	Pnom [W]	1500						1100						
VELOCITA' NOMINALE Rated speed	Nnom [rpm]	3000						2000						
COPPIA NOMINALE Rated torque	Cnom [Nm]	4.8						4.8						
TENSIONE NOMINALE Rated voltage	Vnom [V]	180	110	90	60*	48*	36*	180	110	90*	60*	48*	36*	24*
CORRENTE NOMINALE Rated current	Inom [A]	9.8	15.5	19.6				6.8	11					
COPPIA MASSIMA Peak torque	Cmax [Nm]	24	24	24				24	24					
CORRENTE MASSIMA Peak current	Imax [A]	49	77.5	98.1				34	55					
RESISTENZA ARMATURA Armature resistance	Rarm [Ohm]	0.42	0.22	0.3				1.05	0.45					
INDUTTANZA ARMATURA Armature inductance	La [mH]	1.72	0.73	0.47				4.2	1.65					
COST. TENSIONE Voltage constant	Ke [V/Krpm]	57	35	28.5				84	53.5					
COST. TEMPO ELET. Elect.time constant	Te [ms]	4.1	4.1					4.15	4.1					
COST. TEMPO MECC. Mech.time constant	Tm [ms]	7	8					8	7					

\* Solo per servizio intermittente - Only intermittent duty

**DATI MECCANICI - Mechanical data**

INERZIA ROTORE Rotor inertia	Jm [Kgm <sup>2</sup> ]	0.0051
MAX ACC. TEORICA Max theor. Acc.	[Rad/sec <sup>2</sup> ]	4705
CARICO RADIALE MAX Max radial load	RI [N]	588
CARICO ASSIALE MAX Max axial load	AI [N]	176
PESO MOTORE Motor weight	G [Kg]	17
VENTILAZIONE Ventilation	AUTOVENTILATO T.E.N.V.	
GRADO DI PROTEZIONE Class protection	IP	54

**DATI ELETTRICI - Winding data**

COST. DI TEMPO TERMICO Thermal time constant	Tt [min]	65
MAX VEL. SENZA CARICO Max no load speed	No max [rpm]	4000
MAX VEL. CON CARICO Max load speed	N max [rpm]	3000
CLASSE D'ISOLAMENTO Insulation class		F
FATTORE DI SERVIZIO Duty cycle		S1
FATTORE DI FORMA Form factor	FF	1
TEMP. AMBIENTE RIF. DATI Room temp. data refer.	T rif [°C]	40°

# PENTA7A

MOTORI C.C.

D.C. MOTORS



DIMENSIONI (mm) DIMENSIONS (mm)

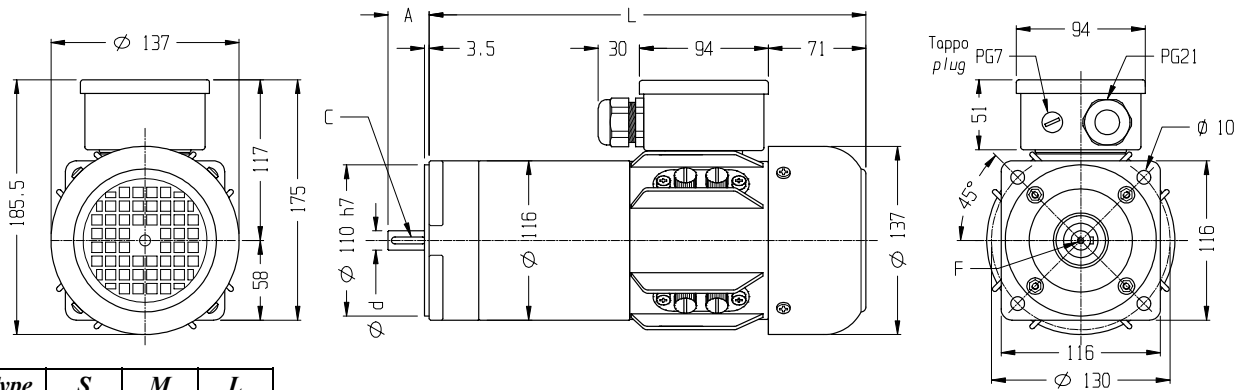

Type	S	M	L
A		40	
L	318	390	462
d(h7)	19		
F	M6		
C	6x6x30		

## FLANGIA B5

## B5 FLANGE

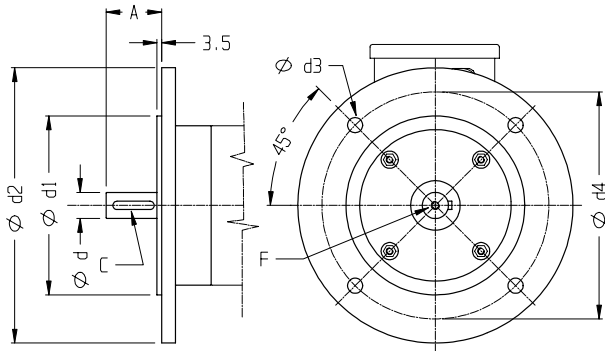

Size	A	C	d(h7)	d1(h7)	d2	d3	d4	F
71	30	5x5x25	14	110	160	9.5	130	M5
80	40	6x6x30	19	130	200	11	165	M6

## FLANGIA B14

## B14 FLANGE

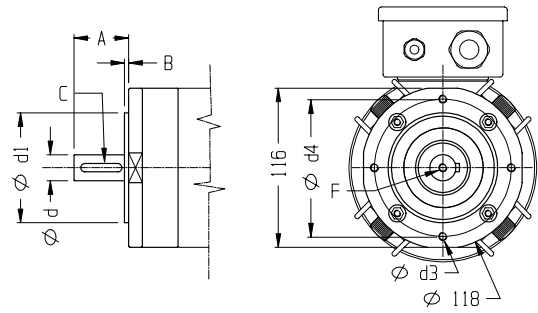

Size	A	B	C	d(h7)	d1(h7)	d3	d4	F
71	30	2.5	5x5x25	14	70	M6	85	M5
80	40	3	6x6x30	19	80	M6	100	M6

# PENTA 7A

MOTORI C.C.

D.C. MOTORS



## OPTIONALS

### PIEDE A FASCIA

FOOT BAND TYPE

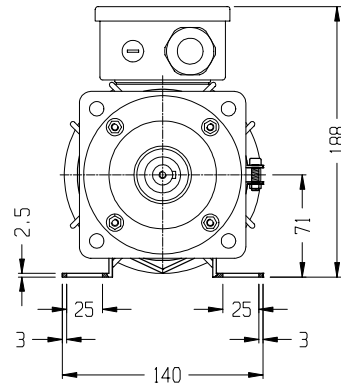
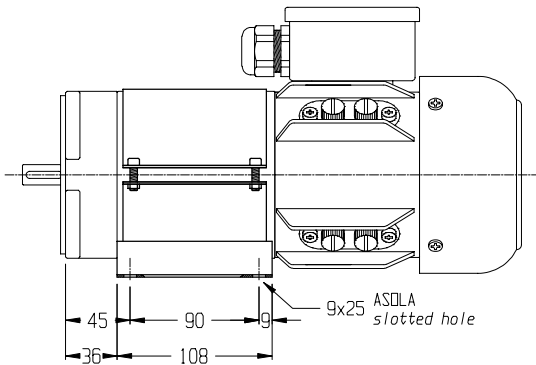

SOLO TAGLIA S  
ONLY TYPE S

### PIEDE A FASCIA

FOOT BAND TYPE

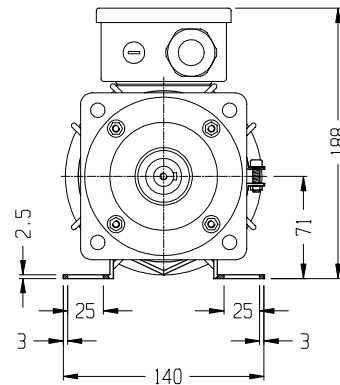
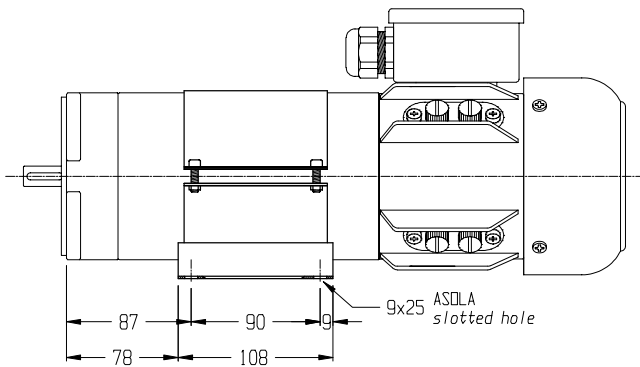

SOLO TAGLIA M  
ONLY TYPE M

### PIEDE A FASCIA

FOOT BAND TYPE

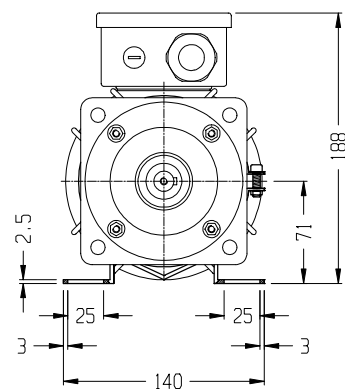
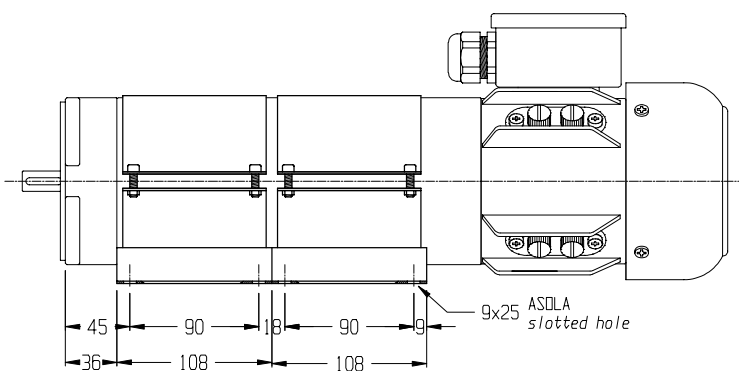

SOLO TAGLIA L  
ONLY TYPE L

# PENTA 7A

MOTORI C.C.

D.C. MOTORS



## OPTIONALS

### DIN. TACHIMETRICA TACHO GENERATOR

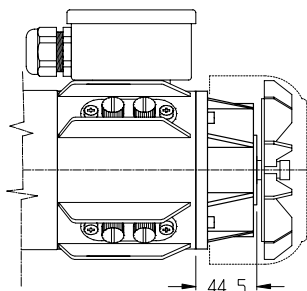

LA LUNGHEZZA TOTALE DEL MOTORE AUMENTA DI 10 mm

<b>COSTANTE DI TENSIONE</b> <i>VOLTAGE CONSTANT</i>	10±5% V/KRPM	<b>CORRENTE NOMINALE</b> <i>RATED CURRENT</i>	2 mA
<b>VELOCITA' MASSIMA</b> <i>MAX SPEED</i>	9000 RPM	<b>CORRENTE MASSIMA</b> <i>MAX CURRENT</i>	8 mA

### FRENO 8 Nm BRAKE 8 Nm

BRAKE 8 Nm

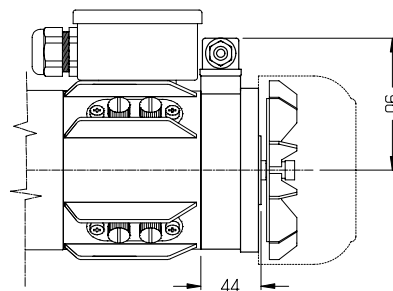

LA LUNGHEZZA TOTALE DEL MOTORE AUMENTA DI 42 mm

<b>COPPIA STATICA</b> <i>STATIC TORQUE</i>	8 Nm	<b>CORRENTE</b> <i>CURRENT</i>	1-0.13 A
<b>TENSIONE DI ALIMEN.</b> <i>POWER SUPPLY VOLTAGE</i>	24-190 V.c.c.	<b>POTENZA ASSORBITA</b> <i>INPUT POWER</i>	24 W



**Brd. Klee A/S**

Gadagervej 11  
2620 Albertslund  
Tel 43 86 83 33  
Fax 43 86 83 88  
klee@klee.dk  
www.klee.dk